

## Original installation and operation manual

Drying system  
**DRYPOINT<sup>®</sup> M** eco control

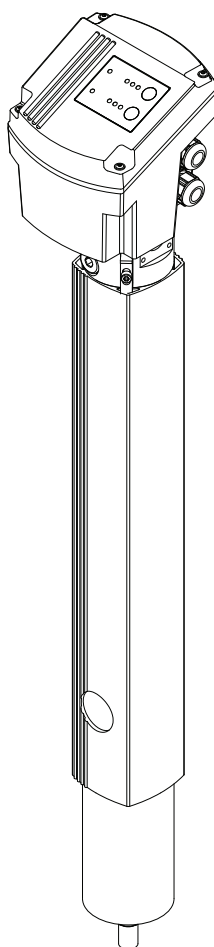

DEC 1-30S  
DEC 2-40S  
DEC 3-60S  
DEC 4-80S  
DEC 5-115S  
DEC 6-135S  
DEC 7-165S  
DEC 8-250S  
DEC 9-330S

## Contents

<b>1. Safety-related information.....</b>	<b>4</b>
<b>1.1. Pictograms and symbols.....</b>	<b>4</b>
1.1.1. In this documentation.....	4
1.1.2. On the device.....	4
<b>1.2. Signal words according to ISO 3864 and ANSI Z.535.....</b>	<b>5</b>
<b>1.3. Safety instructions.....</b>	<b>5</b>
<b>1.4. Transport and storage.....</b>	<b>6</b>
<b>1.5. Intended use.....</b>	<b>7</b>
<b>1.6. Warranty and liability for defects.....</b>	<b>7</b>
<b>2. Product information.....</b>	<b>8</b>
<b>2.1. Scope of delivery.....</b>	<b>8</b>
<b>2.2. Type plate.....</b>	<b>8</b>
2.2.1. Type plate for the drying system.....	8
2.2.2. Type plate for control unit.....	9
<b>2.3. Product overview and description.....</b>	<b>10</b>
<b>2.4. Parts and components.....</b>	<b>11</b>
2.4.1. Basic operating principle.....	12
2.4.2. Operating mode.....	13
<b>2.5. Control and display elements.....</b>	<b>14</b>
<b>2.6. 4 ... 20 mA interface.....</b>	<b>15</b>
<b>2.7. Alarm relay.....</b>	<b>15</b>
<b>2.8. Dimensions.....</b>	<b>16</b>
<b>2.9. Technical data.....</b>	<b>17</b>
<b>3. Assembly.....</b>	<b>21</b>
<b>3.1. Prerequisites.....</b>	<b>21</b>
<b>3.2. Assembly steps.....</b>	<b>22</b>
<b>4. Electrical installation.....</b>	<b>23</b>
<b>4.1. Warning notices.....</b>	<b>23</b>
<b>4.2. Power supply and cable routing.....</b>	<b>23</b>
<b>4.3. Terminal positions.....</b>	<b>24</b>
<b>4.4. Opening the control unit.....</b>	<b>25</b>
<b>4.5. Connection of voltage supply to the power control board.....</b>	<b>26</b>
<b>4.6. Connection of 4 ... 20 mA interfaces on the operating electronic printed circuit board.....</b>	<b>26</b>
<b>4.7. Connection of equipotential contact to the operating electronic printed circuit board.....</b>	<b>26</b>
<b>5. Commissioning.....</b>	<b>26</b>
<b>6. Operation.....</b>	<b>27</b>
<b>6.1. Indicators in operation.....</b>	<b>27</b>
<b>6.2. Solenoid valve test function.....</b>	<b>28</b>
<b>6.3. Carrying out settings (set-up mode).....</b>	<b>28</b>
6.3.1. Amend the operating mode.....	28
6.3.2. Altering the values.....	28

6.3.3. Service mode .....	29
<b>7. Maintenance and servicing.....</b>	<b>30</b>
<b>7.1. Maintenance schedule .....</b>	<b>30</b>
7.1.1. Function and visual inspections.....	30
7.1.2. Exchanging the control unit.....	31
7.1.3. Replace the filter element and float drain .....	35
7.1.4. Wear part exchange .....	39
7.1.5. Measuring the permeation rate.....	49
7.1.6. Cleaning.....	50
<b>8. Spare parts and accessories .....</b>	<b>51</b>
<b>9. Remedying malfunctions, errors, faults and troubleshooting .....</b>	<b>52</b>
<b>9.1. Behaviour in the event of malfunctions/errors, faults .....</b>	<b>52</b>
9.1.1. Failure of the voltage supply .....	52
9.1.2. Sensor failure.....	52
9.1.3. Deviating degree of drying .....	53
<b>9.2. FAQ.....</b>	<b>54</b>
<b>10. Decommissioning .....</b>	<b>56</b>
<b>11. Dismantling and disposal .....</b>	<b>57</b>
11.1. Warning notices .....	57
11.2. Disassembly.....	57
11.3. Disposal of components .....	57
11.4. Preparation for return dispatch .....	57
<b>12. Declaration of Conformity .....</b>	<b>58</b>

# 1. Safety-related information

## 1.1. Pictograms and symbols

### 1.1.1. In this documentation



General note



Note the installation and operation manual



Wear safety goggles



Use hand protection



General hazard symbol (danger, warning, caution)



General hazard symbol (danger, warning, caution) for mains voltage and mains voltage energised plant and system parts

### 1.1.2. On the device



eco label  
Symbol for particularly energy-efficient devices



Maintenance information for nanofilter:  
Details relating to next required filter replacement



General note



General hazard symbol (danger, warning, caution)





General hazard symbol (danger, warning, caution) for mains voltage and mains voltage energised plant and system parts

## 1.2. Signal words according to ISO 3864 and ANSI Z.535

<b>DANGER</b>	<b>Imminent hazard</b> Consequences of non-compliance: serious or even fatal injury
<b>WARNING</b>	<b>Potential hazard</b> Consequences of non-compliance: possibly serious or even fatal injury
<b>CAUTION</b>	<b>Imminent hazard</b> Consequences of non-compliance: injury and/or damage to property
<b>NOTE</b>	<b>Additional notes, information, tips</b> Consequences of non-compliance: Disturbances during operation and maintenance. No hazard to persons.

## 1.3. Safety instructions

<b>DANGER</b>	<b>Escaping compressed gas</b>
	<p>Risk of serious or even fatal injury from suddenly released compressed gas, condensate or unsecured system components.</p> <ul style="list-style-type: none"> <li>• Before carrying out any assembly, installation or maintenance work, depressurise the system. These works may only be executed by authorised skilled technical personnel<sup>1</sup>.</li> <li>• Use only pressure-resistant installation materials and suitable tools that are in proper working order.</li> <li>• Before pressure build-up, check all unit parts and repair them, if necessary. Open valves slowly to prevent pressure blow outs in operating state.</li> <li>• Always prevent people or objects from being affected by condensate or escaping compressed gas.</li> <li>• Prevent vibrations, oscillations and impact from being transferred to system parts.</li> <li>• Perform a leakage test.</li> </ul>
<b>DANGER</b>	<b>Mains voltage</b>
	<p>Risk of electric shock with serious or even fatal injuries if contact is made with non-insulated, live components.</p> <ul style="list-style-type: none"> <li>• Observe all applicable regulations with respect to electrical installations (e.g. VDE 0100 / IEC 60364).</li> <li>• Only execute installation and maintenance works when the system has been de-energised.</li> <li>• Electrical works may only be executed by authorised skilled technical personnel<sup>1</sup>.</li> <li>• Read off the permissible operating voltage on the type plate and always comply with it.</li> <li>• Only utilise components for the electrical installation which have current authorisation and are labelled with a CE-Identification Marking.</li> <li>• A safely accessible circuit breaker (e.g. power plug or switch) must be provided close to the unit for disconnecting all current and/or power lines for the voltage supply.</li> </ul>
<b>WARNING</b>	<b>Operation outside of limit values</b>
	<p>If the specified limit values are undershot and/or exceeded, there is a risk of device malfunction, potentially resulting in injury and/or damage to property.</p> <ul style="list-style-type: none"> <li>• The device must only be operated for the intended purpose and within the permissible limits specified on the type plate and in the technical data.</li> <li>• Strictly adhere to the prescribed operating times and maintenance intervals.</li> <li>• Strictly adhere to the prescribed storage and transport conditions.</li> </ul>

### <sup>1</sup>Skilled technical personnel

Skilled technical personnel are people who, due to their professional qualification and knowledge in the field of measuring, control and pneumatic technology, and their knowledge of the applicable statutory regulations, guidelines and standards are in a position to independently foresee potential dangers in relation to the use of the device and who are qualified to perform the tasks described in this manual. Special operating conditions e.g. aggressive media require additional knowledge.

1.4. Transport and storage

Despite our best efforts, transport damage cannot be excluded. Please therefore remove all packaging material immediately after receipt and inspect the product for any possible transport damage. If you detect any damage, immediately notify the carrier company and **BEKO TECHNOLOGIES GmbH** or one of its agents.

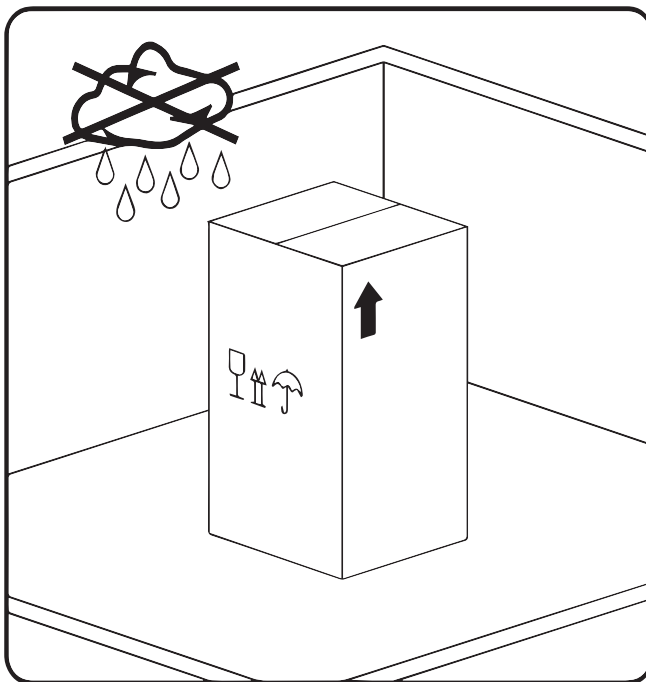

<b>CAUTION</b>	<b>Damage caused during transport or storage</b>
	<p>Inappropriate transport or storage, or the use of unsuitable lifting equipment, might cause damage to the device.</p> <ul style="list-style-type: none"> <li>• The device may only be transported and stored by trained authorised and skilled personnel.</li> <li>• If you detect any damage, do not put the device into operation.</li> <li>• Always comply with the permissible storage and transport temperatures (refer to technical data).</li> <li>• Never expose the device to continuous, direct sunlight or heat radiation.</li> </ul>



The device must be stored in the original packaging. Seal the packaging and store it in a dry and frost-free room. Ensure that the ambient conditions do not fall below or exceed the limits specified on the type plate.

Always take suitable measures to protect the device against the elements even in a packaged condition.

While in storage, secure the device so that it cannot topple over or fall, and protect it against vibration.

<b>NOTE</b>	<b>Recycling packaging material</b>
 	<ul style="list-style-type: none"> <li>• The packaging material is recyclable. Dispose of the packaging material according to the applicable statutory regulations.</li> </ul>

### 1.5. Intended use

The **DRYPOINT® M eco control** drying system with integrated nanofilter and pressure dew point control is designed for the filtration of aerosols and particles from compressed air and subsequent targeted drying of the air according to the individual settings by the user.

The **DRYPOINT® M eco control** may only be operated for the intended purpose and within the specifications stated in the technical data. Do not operate the unit with any substances or gas/vapour mixtures other than those listed above. Any other use of this system, which exceeds the intended use, is hereby deemed to be improper and can cause a hazard for the safety of people and the environment.

- Operating the unit may only be executed within the permissible operating parameter limits (refer to technical data).
- Working pressure is required for the proper functional operation.
- The device is not suitable for operation in explosion hazard areas as well as in areas with aggressive atmospheres.
- Do not operate the device with corrosive gases.
- Strictly observe the prescribed storage and transport conditions.
- The device is not suitable for use in conjunction with CO<sub>2</sub> systems.

In the case of applications in plants with increased requirements for compressed air quality (food industry, medical technology, laboratory equipment or facilities, specialised processes etc.) the operator must decide on measures for the monitoring of the compressed-air quality. These influence the safety for subsequent processes and can prevent injuries to people and damage to plants and systems. It is the duty of the owner and/or operator to always comply with the stated conditions during the entire operating time.

The product and the accessories have been exclusively designed for stationary use in a commercial or industrial area. All the assembly, installation, operation, disassembly and disposal work described may only be performed by qualified skilled technical personnel.

### 1.6. Warranty and liability for defects



All liability claims will be deemed to be invalid if the **DRYPOINT M® eco control** is not utilised in accordance with its intended use or is operated outside the specifications stated in the technical data; this particularly includes:

- Technically incorrect installation, incorrect commissioning, incorrect maintenance or incorrect operation
- Operation with defective components
- Non-compliance with the instructions in this manual, in particular the safety instructions
- Execution of constructive interventions or modifications on the device
- Non-compliance with the prescribed maintenance intervals
- Use of third-party spare parts that have not been approved by the manufacturer for repair and maintenance works

## 2. Product information

### 2.1. Scope of delivery

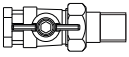
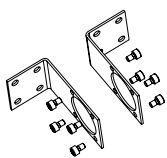
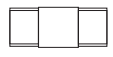
The table below indicates the scope of delivery for the **DRYPOINT® M eco control**.

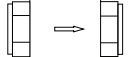
Type	Inlet side		Outlet side	
	Ball valve	Wall bracket	Long nipple/ double nipple	Check valve
DEC 1 ... DEC 6	G 1/2 		G 1/2 	G 1/2 
DEC 7 ... DEC 9	-		G 1 	G 1 

### 2.2. Type plate







The drying system is equipped with two type plates: One type plate for the entire system and one type plate for the control unit.

#### 2.2.1. Type plate for the drying system

**DRYPOINT® M eco control**

Type: DEC6-135S  
 Material-no.: 4039476  
 Serial-no.: 13434090  
 Lot: 201621  
 Element: 06N-V02  
 Element mat.-no.: 4010849  
 Work. temp. TS: +2 ... 50 °C / +35 ... 122 °F  
 Work. pr. PS: 4 ... 10 bar / 58 ... 145 psi  
 Connection: pipe G 1/2  
 Power supply: 95 ... 240 VAC ± 10 %  
 50-60 Hz, max. 20 VA(W)  
 100 ... 125 VDC ± 10 %

Protection-Class: IP 54  
 PED2014/68/EU/Category - Fluid group 2

     

Made in Germany  
**BEKO TECHNOLOGIES**  
 www.beko-technologies.com

Designation	Description
<b>Model:</b>	Model designation
<b>Material No.:</b>	Material number
<b>Serial No.:</b>	Serial number
<b>Batch:</b>	Date of manufacture
<b>Element:</b>	Designation for integrated filter element
<b>Element mat.-no.:</b>	Material number for integrated filter element
<b>Work. temp. TS:</b>	Min./Max. permissible operating temperature
<b>Work. pr. PS:</b>	Min./max. permissible working pressure
<b>Connection:</b>	Pipework connection
<b>Power supply:</b>	Data for voltage supply
<b>Protection-Class:</b>	IP 54
<b>PED2014/68/EU/Category</b>	Permissible fluid group according to European Pressure Equipment Directive



## 2.2.2. Type plate for control unit

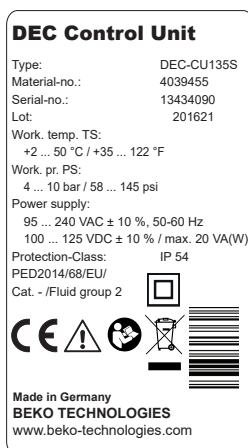

Designation	Description
<b>Model:</b>	Model designation
<b>Material No.:</b>	Material number
<b>Serial No.:</b>	Serial number
<b>Batch:</b>	Date of manufacture
<b>Work. temp. TS:</b>	Min./Max. permissible operating temperature
<b>Work. pr. PS:</b>	Min./max. permissible working pressure
<b>Power supply:</b>	Data for voltage supply
<b>Protection-Class:</b>	IP 54
<b>PED2014/68/EU/Category</b>	Permissible fluid group according to European Pressure Equipment Directive

NOTE	Handling of type plate
	Never damage, remove or make the type plate illegible. For more information regarding the symbols printed on the type plate, see "Pictograms and symbols" on Page 4.

2.3. Product overview and description

The **DRYPOINT® M eco control** is a drying system that guarantees a constant degree of drying at the outlet even under fluctuating operating conditions. The sensor system integrated in the control unit (2) reacts to fluctuating working pressure, inlet pressure dew point as well as different requirements for compressed air quantities. The display and control elements are integrated into the control panel (1). The operating modes as well as specified degree of drying are displayed here. A change of the operating mode or the degree of drying is always possible during running operation.

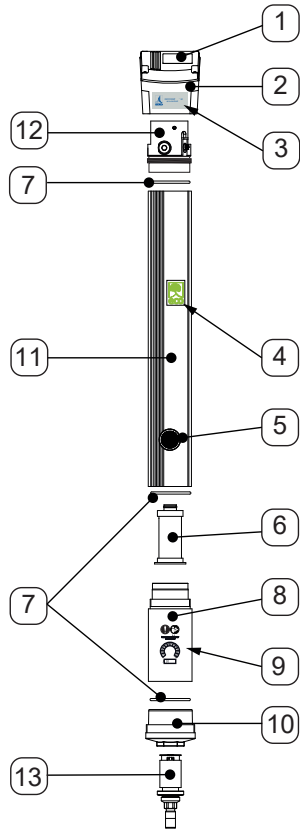

- ① User interface
- ② Control unit/housing head
- ③ Label: **DRYPOINT® M eco control**
- ④ Labels: eco label
- ⑤ Purge air outlet
- ⑥ Nanofilter element
- ⑦ O-rings (housing)
- ⑧ Housing extension
- ⑨ Maintenance label: Filter replacement
- ⑩ Housing base
- ⑪ Housing body with membrane element
- ⑫ Membrane dryer head
- ⑬ Float drain

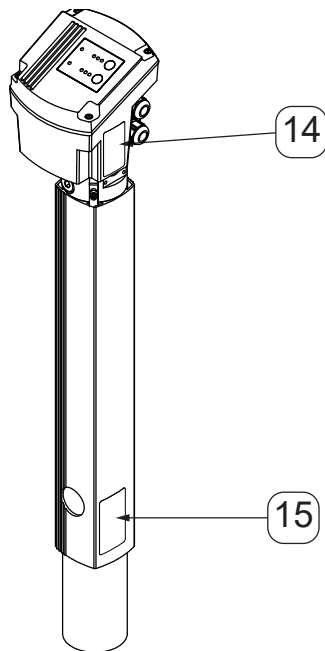

- ⑭ Type plate for the control unit
- ⑮ Type plate for the drying system

2.4. Parts and components

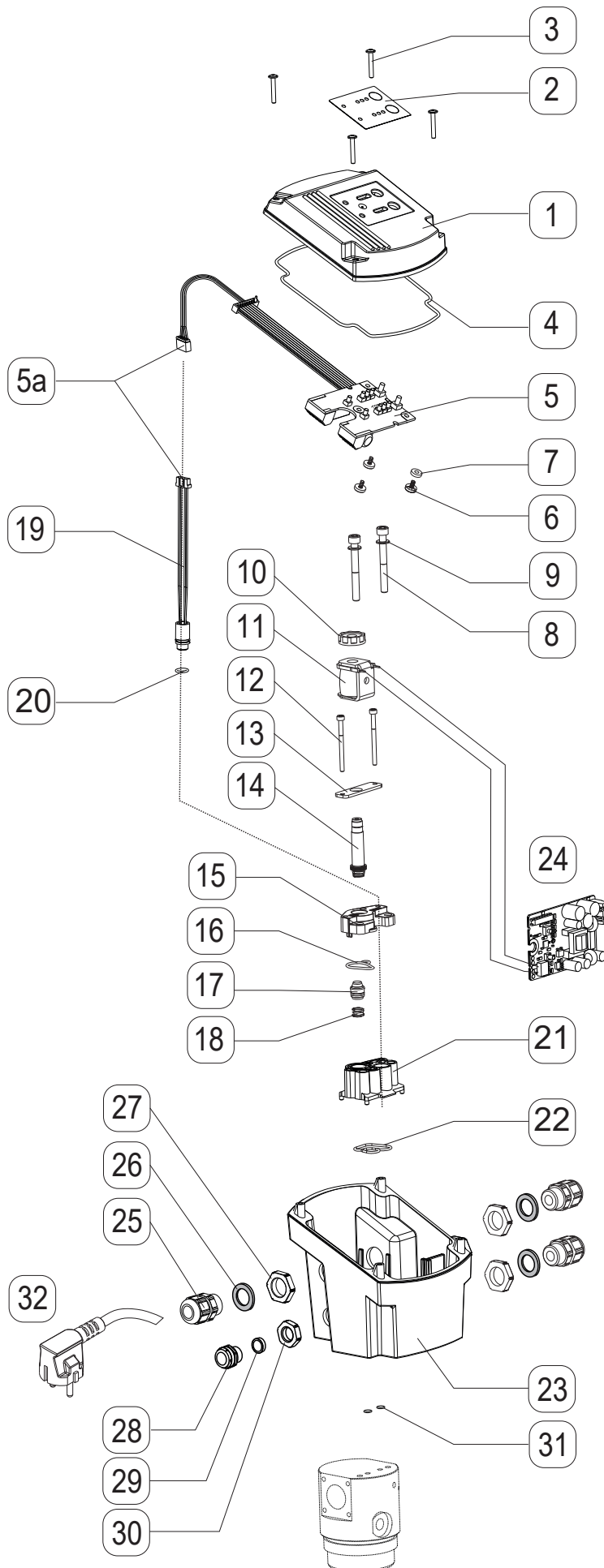

- 1 Hood
- 2 Keyboard foil
- 3 Mushroom head bolt M3 x 20
- 4 Cord packing
- 5 Display electronic printed circuit board with plug connection
- 5a Plug connection sensor
- 6 Countersunk head screw M3 x 8
- 7 Plastic washer
- 8 Screw M5 x 45
- 9 Washer 5.3
- 10 Knurled nut anchor system
- 11 Coil with cable 150 mm and plug-type connection
- 12 Screw M3 x 40
- 13 Retaining plate
- 14 Anchor system Magnetic core and core guide pipe
- 15 Pilot valve seat
- 16 Seal pilot valve seat
- 17 Valve piston with seal
- 18 Pressure spring switch-over valve
- 19 Sensor with cable and plug connection
- 20 O-ring 8 x 1.5
- 21 Switch-over valve seat
- 22 Seal switch-over valve seat
- 23 Housing
- 24 Control electronic printed circuit board
- 25 Cable gland M16 x 1.5
- 26 Seal
- 27 Counter nut M16 x 1
- 28 Pressure compensation plug
- 29 Sleeve
- 30 Counter nut M12 x 1.5
- 31 O-ring 6 x 2
- 32 Power cable with plug

2.4.1. Basic operating principle

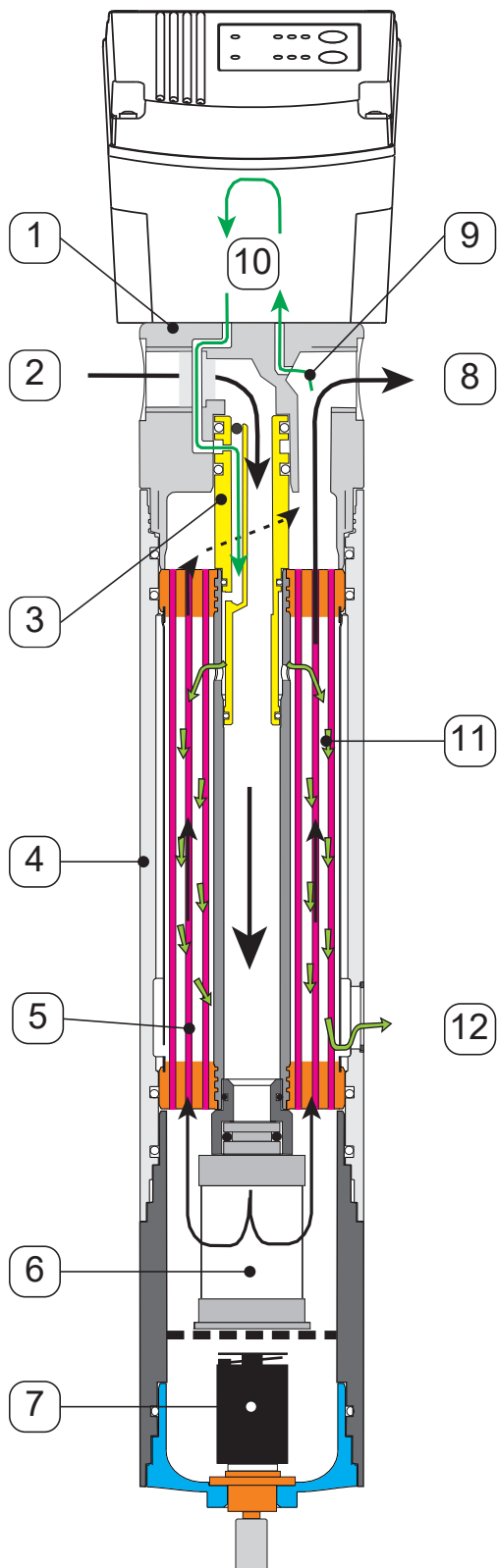

Humid compressed air (2) enters the unit through the housing head (1) and flows downwards through the rigid pipe of the membrane element (5) into the housing (4). It then passes through the nanofilter (6) installed at the condensate drain of the core tube where all residual aerosols and particles are removed from the compressed air. Separated condensate flows out of the base and is routed through the float drain (7).

The flow direction is reversed in the nanofilter element area and the humid compressed air flows through the membranes of the internal membrane element.

Some of the compressed air flow (9) is diverted downstream of the membrane element and passed by the sensor continuously in the purge air control.

The sensor measuring results are evaluated in the purge air control and the purge air feed to the membrane dryer is opened as required. As a result, the purge air decreases to atmospheric pressure and is considerably dryer as the damp contained in the compressed air is distributed to a multiple of the original volume.

The very dry purge air (10) is fed via the purge air duct in the head and the purge air nozzle (3) on the external side of the diaphragm (11) and evenly distributed by the arranged position of the diaphragms. This means that two air flows move through the membrane element (5) in an opposite direction with differential damp content:

Damp compressed air on the inside and dry purge air on the outside.

Due to the damp difference, water diffuses from the compressed air into the purge air. The damp purge air (12) is then released to the ambient air. The compressed air (8) exits as dry from the membrane dryer.

The control software decides in defined cycles on the basis of the measurement results whether, and for how long, the complete purge air volume must be supplied in order to achieve and stabilise the required degree of drying. This process is implemented via a targeted cycling of a solenoid valve. The duration for both subsequent described process steps therefore varies in every cycle to retain the degree of drying within the specified tolerance range.

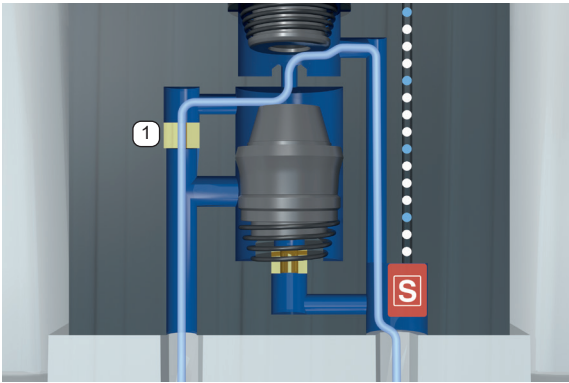

**Function: Measuring gas flows**

A very small partial flow of the dried compressed air (measuring gas) flows continuously through the internal duct guide past a temperature and damp sensor (S) to the measuring gas jet (1). This sensor continuously specifies the degree of drying for the compressed air in the measuring gas and notifies the result to the control system.

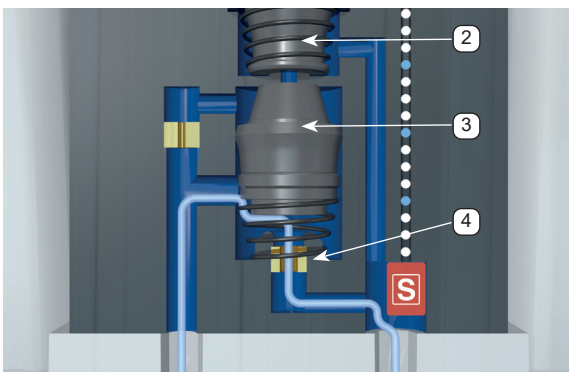

**Function: Purge air flows**

The control system continuously compares the measured degree of drying of the measuring gas with the individual specified set point at the **DRYPOINT® M eco control**. The valve unit is actuated with deviations: The solenoid core (2) and piston (3) close the valve seat so that the compressed air flows through the purge air nozzle (4) to the membrane dryer. The drying process commences immediately.

**2.4.2. Operating mode**

**Constant mode (-10 °C; factory-set as default)** - Setting for a constant outlet pressure dew point:

In this mode, the **DRYPOINT® M eco control** keeps the pressure dew point set at the outlet constant between +10 and -26 °C. If the set pressure dew point is < 5K (kelvin) below the compressed-air temperature, then the set point pressure dew point is reduced by one stage (maximum. -26 °C). As soon as the minimum difference of 5K is retained, then the system returns to normal mode.

**Dynamic mode** - constant difference between compressed air temperature and outlet pressure dew point:

In this operating mode, the pressure dew point is reduced relative to the compressed air temperature by a specified difference between 10 and 55 K. If the compressed air temperature alters, then the pressure dew point will automatically follow suit. For programme-technical reasons, an increase in the compressed air temperature is limited to 2 °C/h in order to reduce short-term alterations in the ambient conditions at the installation and/or assembly location.

**Note on setting dynamic mode:**

- The membrane dryer must always reach a degree of drying that safely prevents the formation of condensation in the pipes to and at the place of installation of the compressed air consumer:  $DTP_{\text{Outlet}} [^{\circ}\text{C}] < T_{\text{Ambient}} [^{\circ}\text{C}]$ .
- A well ventilated compressor chamber and a low compressed air temperature contribute to ensuring a good degree of drying.

→ Measure the temperature at the compressor's place of installation and in the environment around the compressed air consumer.

Recommended settings on the basis of the temperature difference  $\Delta T$  between compressor chamber and compressed air consumer:

$\Delta T$ in [K]	10	15	20	25	30	35
Setting "dynamic mode"	30	35	40	45	50	55

### 2.5. Control and display elements

The **DRYPOINT® M eco control** drying system is operated using the user interface on the top of the housing. The current operating status is represented by LED indicators.

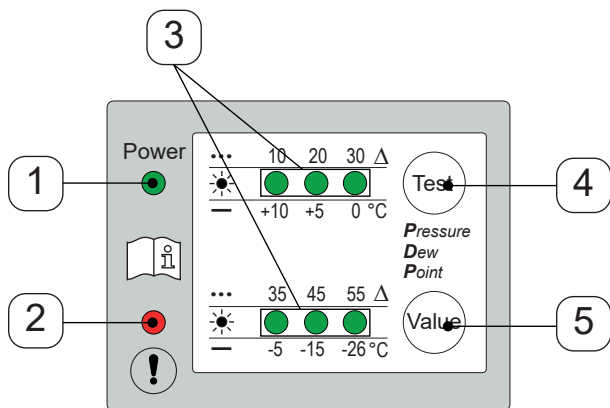

- 1 Power LED (green)**  
Indicator for operating mode and voltage supply
- 2 Warning LED (red)**  
Indicator for alarms, errors and malfunctions in operation
- 3 Value LED (green)**  
Indicator for the set point values
- 4 >>Test<< button**  
Setting the operating mode or for testing the solenoid valve function
- 5 >>Value<< button**  
Setting the degree of drying or activating the service mode
- 4 + 5 Press and hold the >>Test<< + >>Value<< buttons**  
Unlock software → change settings

The pressure points on the >>Test<< and >>Value<< buttons are designed in such a way that inadvertent touching cannot trigger operating functions. The software is programmed in such a way that a button must be pressed for a longer time (approx. 0.2 second) to acquire a desired operating function.

If an operation function is initiated with a continuous pressing of the button(s), then the device will indicate the possible commencement of the operation: All green value LEDs (3) flash. A time span of 10 seconds is then open for the action after releasing the button(s). Every actuation of a button during this time span will result in the time span being available again for the complete duration.

Once the action has been completed and no button has been pressed for 10 seconds, then the confirmation for finalising the action is executed via the control →. All green value LEDs (3) flash. The system then transfers into normal mode and is controlled on the basis of the prescribed settings.

NOTE	Additional information
	For more information regarding the display and the test function of the solenoid valve, see “Operation” on Page 27.

## 2.6. 4 ... 20 mA interface

The drying system is equipped with a 4 ... 20 mA interface via which the currently measured pressure dew point can be issued (irrespective of operating mode).

4 mA  $\triangleq$  -48 °C

20 mA  $\triangleq$  +25 °C

Output value in case of error: 24 mA

Increments: 0.5 °C

## 2.7. Alarm relay

The drying system is equipped with an alarm relay via which an error signal can be issued. There will not be a differentiation here between various types of errors.

### Error list:

- Sensor fault (Refer to 9.1.2)
- Exceeding the permissible deviation for degree of drying (Refer to 9.1.3)
- Failure of the voltage supply (Refer to 9.1.1)

2.8. Dimensions

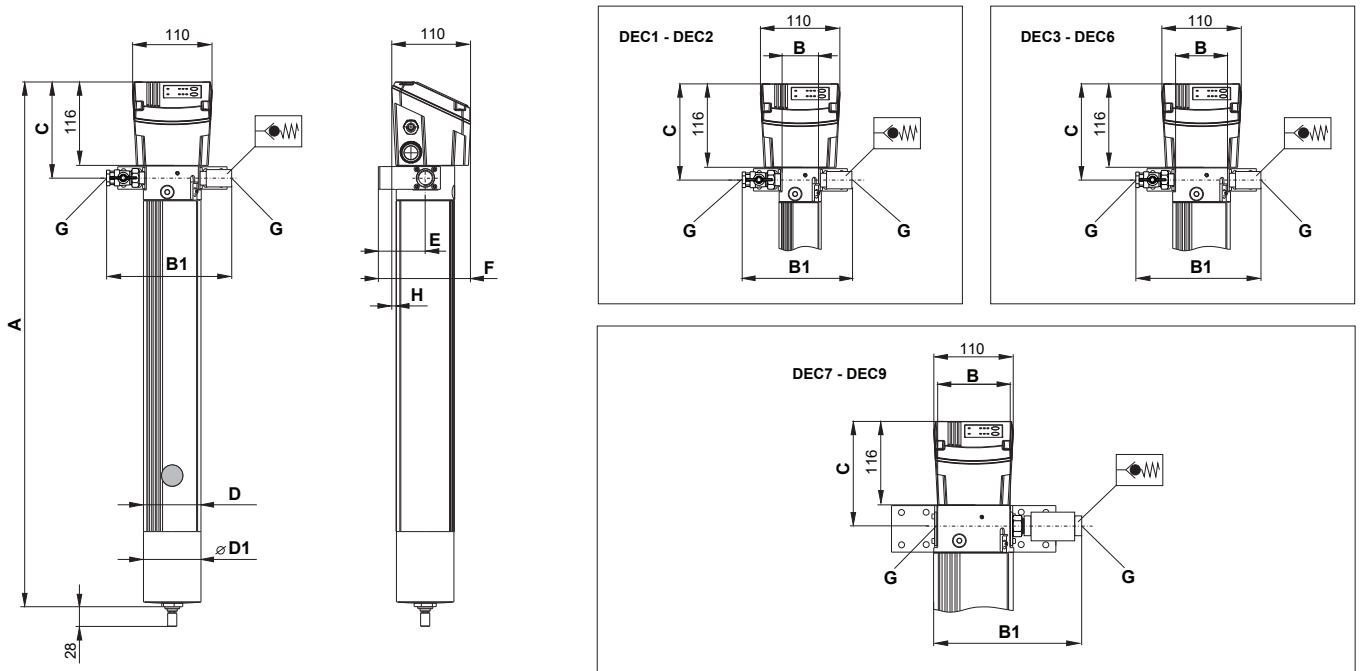

Dimensions	DEC 1-30S	DEC 2-40S	DEC 3-60S	DEC 4-80S	DEC 5-115S	DEC 6-135S	DEC 7-165S	DEC 8-250S	DEC 9-330S
A (mm)	625	685	695	745	815	885	889	1029	1179
B (mm)	52	52	72	72	72	72	104	104	104
B1 (mm)	approx. 195	approx. 195	approx. 215	approx. 215	approx. 215	approx. 215	approx. 210	approx. 210	approx. 210
C (mm)	133	133	133	133	133	133	141	141	141
D/D1 (ø mm)	60/60	60/60	80/80	80/80	80/80	80/80	120/120	120/120	120/120
E (mm)	65	65	63	63	63	63	78	78	78
F (mm)	128	128	126	126	126	126	141	141	141
G (mm)	1/2"	1/2"	1/2"	1/2"	1/2"	1/2"	1"	1"	1"



## 2.9. Technical data

Technical data									
	DEC 1-30S	DEC 2-40S	DEC 3-60S	DEC 4-80S	DEC 5-115S	DEC 6-135S	DEC 7-165S	DEC 8-250S	DEC 9-330S
Installation size DRYPOINT® M plus	10-41	10-47	20-48	20-53	20-60	20-67	40-61	40-75	40-90
Min./max. working pressure	4 ... 10 bar(g)								
Excess pressure protection housing	Pressure compensation plug								
Min./max. storage/transport temperature	+2 ... +50 °C, frost-free								
Min./max. Ambient temperature	+2 ... +50 °C, frost-free								
Min./max. media temperature	+2 ... +50 °C, frost-free								
Medium	Fluid group 2: Compressed air/nitrogen								
Medium and quality at membrane dryer inlet	Only neutral medium in accordance with PED 2014/68/EU with Class [3: - :3] ISO 8573-1								
Noise level	<< 45 dB (A), no expansion pop								
Installation position	Vertical								
Weight [kg]	3.4	3.6	4.9	5.2	5.5	5.8	10.9	12.0	13.1
Materials	Media-contacting parts as corrosion-proof Materials conforming to RoHS and REACH regulations Plastic components conforming to UL regulations								
Integrated nanofilter	0.01 µm / 0.005 mg/m <sup>3</sup>								
Pressure loss	0.1 - 0.3 bar, depending on the compressed air volume flow								
PDP outlet settings	+10 / +7 / +5 / +3 / 0 / -5 / -10 / -15 / -20 / -26 °C								
PDP difference settings	10 / 15 / 20 / 25 / 30 / 35 / 40 / 45 / 50 / 55 K (Kelvin)								
Electrical data									
Operating voltage	95 ... 240 VAC ± 10% (50 ... 60 Hz) / 100 ... 125 VDC ± 10% or 24 ... 48 VAC ± 10% (50 ... 60 Hz) / 18 ... 72 VDC ± 10%								
Power consumption	max. 20 VA (W) with permanently closed solenoid valve								
Recommended wire cross-section	min. 0.5 mm <sup>2</sup>								
Recommended connection cable	2-wired, diameter 5 ... 10 mm								
Degree of protection	IP 54								
Min./max. contact load (potential-free contact)	max. 12 VAC / 1 A or 24 VDC / 1 A; min. 5 VDC / 10 mA								
Signal output	4...20 mA (PDP outlet)								
Interfaces	2 x cable connection M16, cable diameter 5 ... 10 mm								

PDP inlet			Volume flow inlet in l/minute at 10 bar								
+35 °C	+20 °C	+5 °C	DEC 1-30S	DEC 2-40S	DEC 3-60S	DEC 4-80S	DEC 5-115S	DEC 6-135S	DEC 7-165S	DEC 8-250S	DEC 9-330S
	+10°C		628	837	1256	1674	2318	2721	3220	4911	6521
	+5°C	-5°C	499	660	990	1320	1835	2157	2576	3832	5120
+10°C	0°C	-10°C	393	523	797	1055	1465	1723	2061	3059	4089
+5°C	-5°C	-15°C	335	448	671	895	1256	1473	1755	2657	3526
0°C	-10°C		293	390	586	781	1103	1296	1562	2383	3156
-5°C		-20°C	261	348	522	696	990	1167	1401	2141	2850
-10°C	-15°C		240	319	478	638	910	1071	1296	1980	2624
-15°C	-20°C	-26°C	219	293	440	586	837	982	1199	1819	2415
-20°C	-26°C		204	272	407	544	779	918	1111	1691	2238
-26°C			190	253	380	507	728	853	1030	1570	2093
PDP outlet			41	55	82	110	158	185	226	343	452
10 bar			Purge air in l/minute at 10 bar *								

\* the intrinsic permeability is approx. <5% relating to the purge air volume.

PDP inlet			Volume flow inlet in l/minute at 9 bar								
+35 °C	+20 °C	+5 °C	DEC 1-30S	DEC 2-40S	DEC 3-60S	DEC 4-80S	DEC 5-115S	DEC 6-135S	DEC 7-165S	DEC 8-250S	DEC 9-330S
	+10°C		546	728	1092	1456	2016	2366	2800	4270	5670
	+5°C	-5°C	434	574	861	1148	1596	1876	2240	3332	4452
+10°C	0°C	-10°C	342	455	693	917	1274	1498	1792	2660	3556
+5°C	-5°C	-15°C	291	389	584	778	1092	1281	1526	2310	3066
0°C	-10°C		255	339	510	679	959	1127	1358	2072	2744
-5°C		-20°C	227	302	454	605	861	1015	1218	1862	2478
-10°C	-15°C		209	277	416	554	791	931	1127	1722	2282
-15°C	-20°C	-26°C	190	255	382	510	728	854	1043	1582	2100
-20°C	-26°C		178	237	354	473	678	798	966	1470	1946
-26°C			165	220	330	441	633	742	896	1365	1820
PDP outlet			38	50	75	100	144	169	206	313	413
9 bar			Purge air in l/minute at 9 bar *								

\* the intrinsic permeability is approx. <5% relating to the purge air volume.

PDP inlet			Volume flow inlet in l/minute at 8 bar								
+35 °C	+20 °C	+5 °C	DEC 1-30S	DEC 2-40S	DEC 3-60S	DEC 4-80S	DEC 5-115S	DEC 6-135S	DEC 7-165S	DEC 8-250S	DEC 9-330S
	+10°C		464	619	928	1238	1714	2011	2380	3630	4820
	+5°C	-5°C	369	488	732	976	1357	1595	1904	2832	3784
+10°C	0°C	-10°C	290	387	589	779	1083	1273	1523	2261	3023
+5°C	-5°C	-15°C	248	331	496	662	928	1089	1297	1964	2606
0°C	-10°C		217	288	433	577	815	958	1154	1761	2332
-5°C		-20°C	193	257	386	514	732	863	1035	1583	2106
-10°C	-15°C		177	236	353	471	672	791	958	1464	1940
-15°C	-20°C	-26°C	162	217	325	433	619	726	887	1345	1785
-20°C	-26°C		151	201	301	402	576	678	821	1250	1654
-26°C			140	187	281	375	538	631	762	1160	1547
PDP outlet			34	45	67	90	129	151	185	280	370
8 bar			Purge air in l/minute at 8 bar *								

\* the intrinsic permeability is approx. <5% relating to the purge air volume.

PDP inlet			Volume flow inlet in l/min at 7bar								
+35 °C	+20 °C	+5 °C	DEC 1-30S	DEC 2-40S	DEC 3-60S	DEC 4-80S	DEC 5-115S	DEC 6-135S	DEC 7-165S	DEC 8-250S	DEC 9-330S
	+10°C		390	520	780	1040	1440	1690	2000	3050	4050
	+5°C	-5°C	310	410	615	820	1140	1340	1600	2380	3180
+10°C	0°C	-10°C	244	325	495	655	910	1070	1280	1900	2540
+5°C	-5°C	-15°C	208	278	417	556	780	915	1090	1650	2190
0°C	-10°C		182	242	364	485	685	805	970	1480	1960
-5°C		-20°C	162	216	324	432	615	725	870	1330	1770
-10°C	-15°C		149	198	297	396	565	665	805	1230	1630
-15°C	-20°C	-26°C	136	182	273	364	520	610	745	1130	1500
-20°C	-26°C		127	169	253	338	484	570	690	1050	1390
-26°C			118	157	236	315	452	530	640	975	1300
<b>PDP outlet</b>			30	40	60	80	115	135	165	250	330
<b>7 bar</b>			<b>Purge air in l/minute at 7 bar *</b>								

\* the intrinsic permeability is approx. <5% relating to the purge air volume.

PDP inlet			Volume flow inlet in l/minute at 6 bar								
+35 °C	+20 °C	+5 °C	DEC 1-30S	DEC 2-40S	DEC 3-60S	DEC 4-80S	DEC 5-115S	DEC 6-135S	DEC 7-165S	DEC 8-250S	DEC 9-330S
	+10°C		300	400	601	801	1109	1301	1540	2349	3119
	+5°C	-5°C	239	316	474	631	878	1032	1232	1833	2449
+10°C	0°C	-10°C	188	250	381	504	701	824	986	1463	1956
+5°C	-5°C	-15°C	160	214	321	428	601	705	839	1271	1686
0°C	-10°C		140	186	280	373	527	620	747	1140	1509
-5°C		-20°C	125	166	249	333	474	558	670	1024	1363
-10°C	-15°C		115	152	229	305	435	512	620	947	1255
-15°C	-20°C	-26°C	105	140	210	280	400	470	574	870	1155
-20°C	-26°C		98	130	195	260	373	439	531	809	1070
-26°C			91	121	182	243	348	408	493	751	1001
<b>PDP outlet</b>			26	35	52	70	100	117	144	218	287
<b>6 bar</b>			<b>Purge air in l/minute at 6 bar *</b>								

\* the intrinsic permeability is approx. <5% relating to the purge air volume.

PDP inlet			Volume flow inlet in l/minute at 5 bar								
+35 °C	+20 °C	+5 °C	DEC 1-30S	DEC 2-40S	DEC 3-60S	DEC 4-80S	DEC 5-115S	DEC 6-135S	DEC 7-165S	DEC 8-250S	DEC 9-330S
	+10°C		218	291	437	582	806	946	1120	1708	2268
	+5°C	-5°C	174	230	344	459	638	750	896	1333	1781
+10°C	0°C	-10°C	137	182	277	367	510	599	717	1064	1422
+5°C	-5°C	-15°C	116	156	234	311	437	512	610	924	1226
0°C	-10°C		102	136	204	272	384	451	543	829	1098
-5°C		-20°C	91	121	181	242	344	406	487	745	991
-10°C	-15°C		83	111	166	222	316	372	451	689	913
-15°C	-20°C	-26°C	76	102	153	204	291	342	417	633	840
-20°C	-26°C		71	95	142	189	271	319	386	588	778
-26°C			66	88	132	176	253	297	358	546	728
<b>PDP outlet</b>			23	30	45	60	86	101	124	188	248
<b>5 bar</b>			<b>Purge air in l/minute at 5 bar *</b>								

\* the intrinsic permeability is approx. <5% relating to the purge air volume.

PDP inlet			Volume flow inlet in l/minute at 4 bar								
+35 °C	+20 °C	+5 °C	DEC 1-30S	DEC 2-40S	DEC 3-60S	DEC 4-80S	DEC 5-115S	DEC 6-135S	DEC 7-165S	DEC 8-250S	DEC 9-330S
	+10°C		152	203	304	406	562	659	780	1190	1580
	+5°C	-5°C	121	160	240	320	445	523	624	928	1240
+10°C	0°C	-10°C	95	127	193	255	355	417	499	741	991
+5°C	-5°C	-15°C	81	108	163	217	304	357	425	644	854
0°C	-10°C		71	94	142	189	267	314	378	577	764
-5°C		-20°C	63	84	126	168	240	283	339	519	690
-10°C	-15°C		58	77	116	154	220	259	314	480	636
-15°C	-20°C	-26°C	53	71	106	142	203	238	291	441	585
-20°C	-26°C		50	66	99	132	189	222	269	410	542
-26°C			46	61	92	123	176	207	250	380	507
PDP outlet			19	25	38	50	72	85	104	158	208
4 bar			Purge air in l/minute at 4 bar *								

\* the intrinsic permeability is approx. <5% relating to the purge air volume.

**Product selection:**

Example for selection drying system for:

- Volume flow utilisation air: 180 l/min
- Working pressure: 4 bar
- PDP reduction: +5 °C to -20 °C

Search in table for performance data 4 bar

Column PDP inlet “+5 °C“ up to the row “-20 °C“ (PDP outlet)

Search for a value in this row which is larger than the utilisation air flow

→ Column DEC 5-115S fulfils this requirement with nominal value 240 l/minute

Purge air consumption DEC 5-115S: 72 l/minute must be deducted from the inlet volume flow

Max. utilisation volume flow: 168 l/minute → device too small → select larger device DEC 6-135S

### 3. Assembly

#### 3.1. Prerequisites

A prerequisite for a good drying result is an efficient preliminary filtration. Only when the subsequent recommended preliminary filtration is retained is it possible to achieve trouble-free drying results. The required preliminary filtration can be obtained from the following overview:

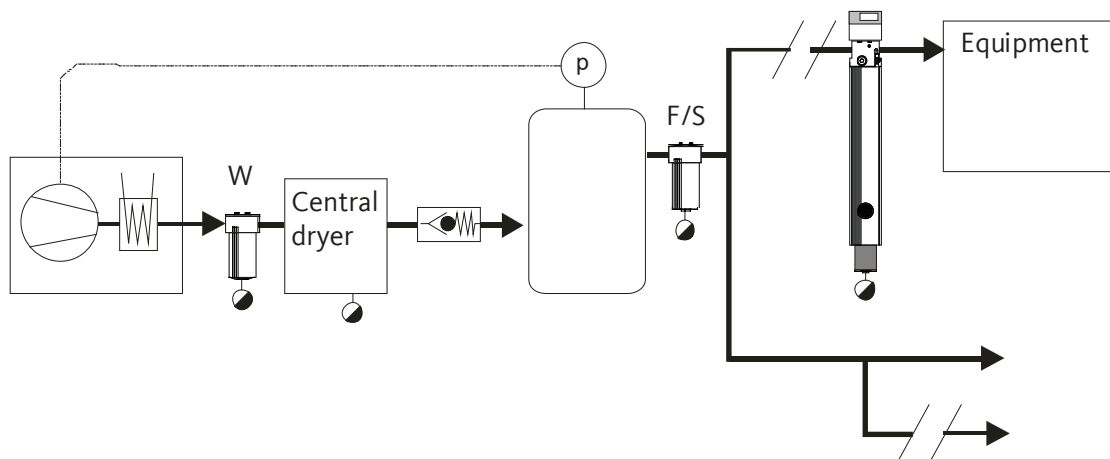
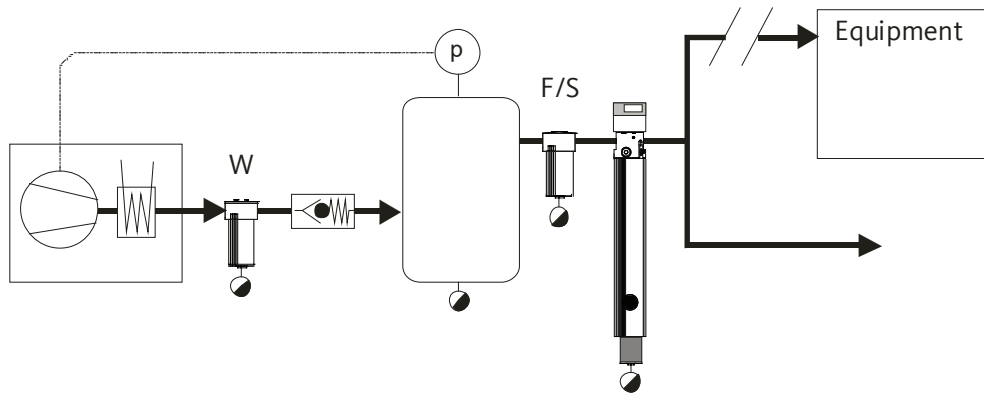

W = Wasserabscheider / Water separator

F = Feinfilter für die Verwendung mit ölfreien Kompressoren / Fine filter for the application with oilfree compressors

S = Feinfilter für die Verwendung mit ölgeschmierten Kompressoren / Super fine filter for the application with oil lubricated compressors

3.2. Assembly steps

Preparatory tasks	
1.	Depressurise the device and secure against pressure being applied again:
2.	De-energise the device and secure it against being switched back on again. Remove the mains plug. → A “click” noise indicates the opening of the solenoid valve. → Pressure drop is taking place in the device.

The installation of the **DRYPOINT® M eco control** drying system must be executed depending on the direction of flow of the compressed air. The purge air outlet (2) points from left → right to the front for orienting.

- It is recommended that a bypass pipe (1) is installed for maintenance and service works. Take into account hereby that 30 cm space is required for the operation of the control unit.
- Assemble the supplied long nipples and check valve in the outlet of the membrane dryer in the through flow direction (refer to the arrow on the check valve).
- The purge air must be able to flow unimpaired from the area covered by the screen (2).
- The installation room and/or the contained units, plants, systems and equipment must not release chemical substances.
- The installation location must be frost free, the temperature at the installation location, as well as the compressed air temperature, must be between +2 and +50 °C.
- Always thoroughly clean the pipework network before the installation (e.g. by blowing through)
- Seal all threads with Teflon tape → do not use liquid sealants.
- Install the unit so that no damage to the drying system can occur during filter replacement.

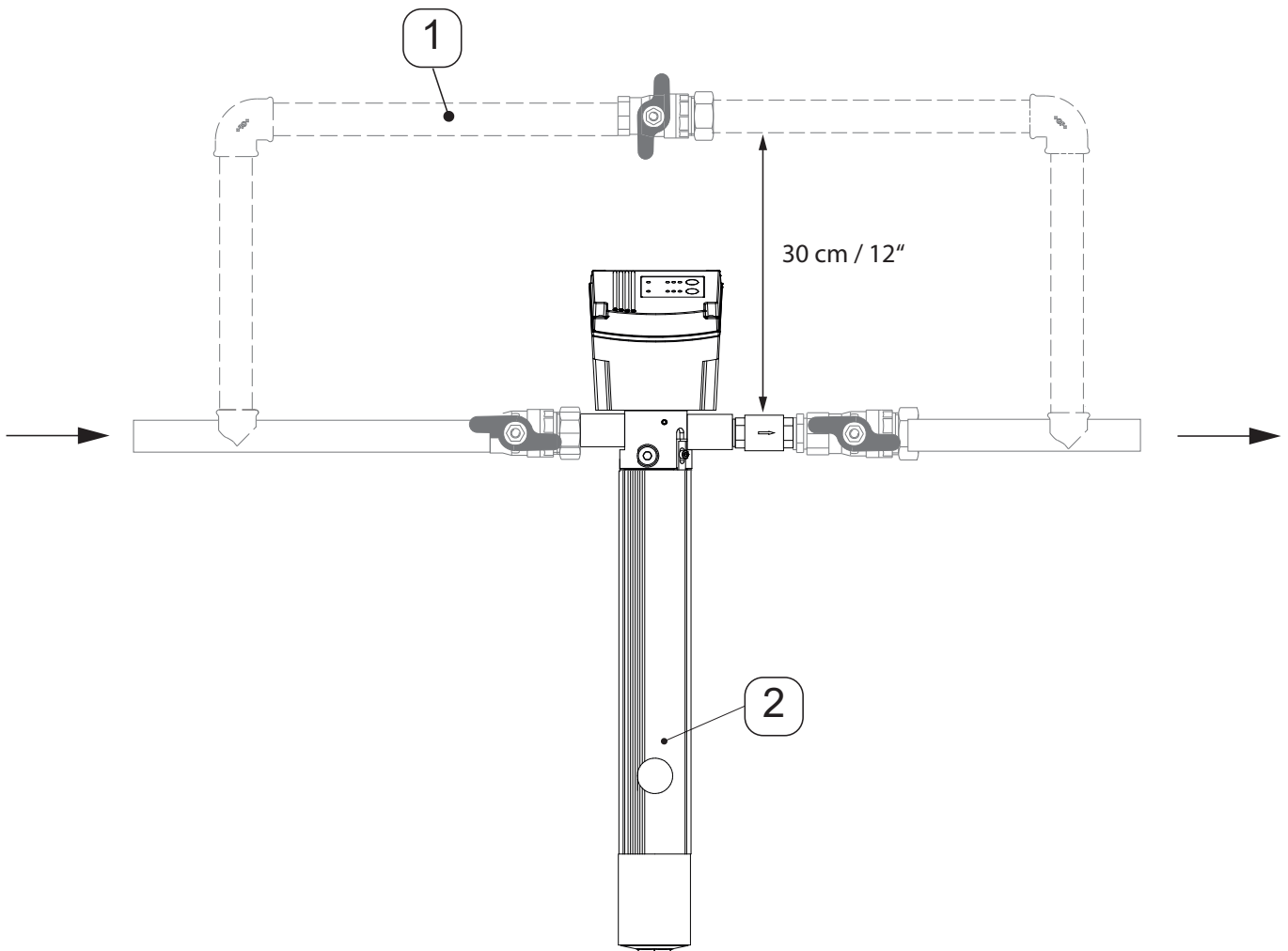

## 4. Electrical installation

### 4.1. Warning notices

<b>DANGER!</b>	<b>Mains voltage</b>
	<p>Risk of electric shock with serious or even fatal injuries if contact is made with non-insulated, live components.</p> <ul style="list-style-type: none"> <li>• Observe all applicable regulations with respect to electrical installations (e.g. VDE 0100 / IEC 60364).</li> <li>• Electrical works may only be executed by authorised skilled technical personnel<sup>1</sup>.</li> <li>• Read off the permissible operating voltage on the type plate and always comply with it.</li> <li>• Only utilise components for the electrical installation which have current authorisation and are labelled with a CE-Identification Marking.</li> <li>• A safely accessible circuit breaker (e.g. power plug or switch) must be provided close to the unit for disconnecting all current and/or power lines for the voltage supply.</li> <li>• Never execute any connection works when the system is energised.</li> </ul>

#### <sup>1</sup>Skilled technical personnel

Skilled technical personnel are people who, due to their professional qualification and knowledge in the field of measuring, control and pneumatic technology, and their knowledge of the applicable statutory regulations, guidelines and standards are in a position to independently foresee potential dangers in relation to the use of the device and who are qualified to perform the tasks described in this manual. Special operating conditions e.g. aggressive media require additional knowledge.

The control unit of the **DRYPOINT® M eco control** drying system is factory equipped with a power cable and device connection plug. It is therefore not necessary to open the control unit to connect it to the power supply.

### 4.2. Power supply and cable routing

<b>NOTE</b>	<b>Power supply and electromagnetic interference!</b>
	<p>Inappropriate connection and long cable routes promote electromagnetic interference and can impair function.</p> <ul style="list-style-type: none"> <li>• Do not remove split ferrite from the mains cable.</li> <li>• Do not connect any other devices via the internal voltage supply of the <b>DRYPOINT® M eco control</b>.</li> <li>• Keep the mains cable between the socket and the <b>DRYPOINT® M eco control</b> as short as possible, wind if appropriate.</li> </ul>

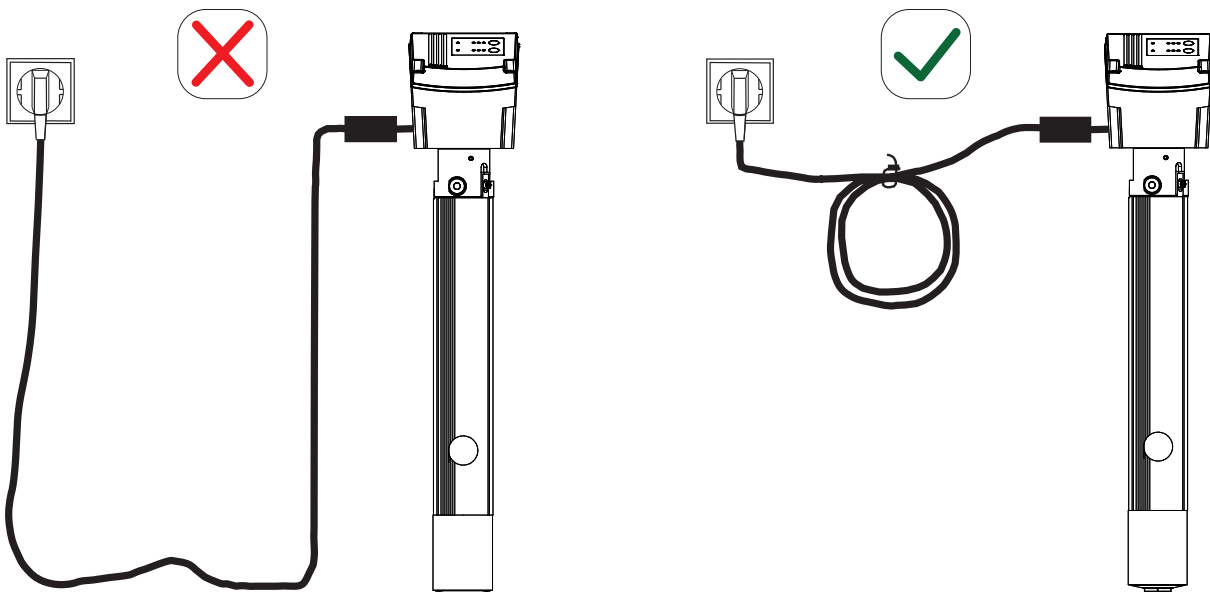

### 4.3. Terminal positions

The following illustration (without hood) indicates the position of the electronic printed circuit boards and the associated terminal connections.

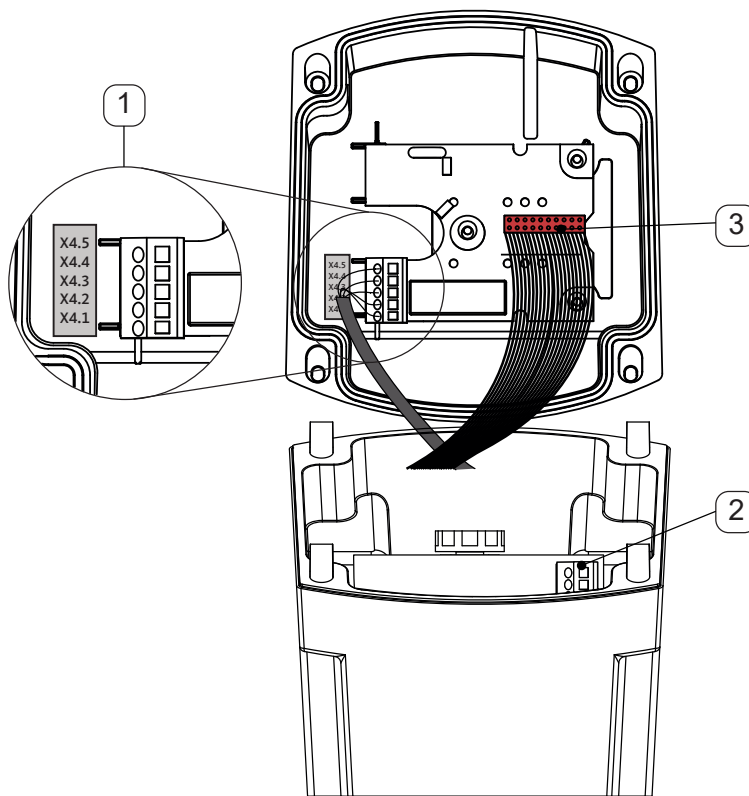

1	Operating electronic printed circuit board with terminal for 4 ... 20 mA interfaces and equipotential contact
2	Power control board with terminal for voltage supply



#### 4.4. Opening the control unit

For the electrical connection of the 4 ... 20 mA interfaces and/or the alarm contact, the housing of the control unit must be opened. Loosen the 4 housing screws, using a 2 mm Allen key to perform this task. Cable routing is executed via the provided armoured conduit fitting (4) or (5).

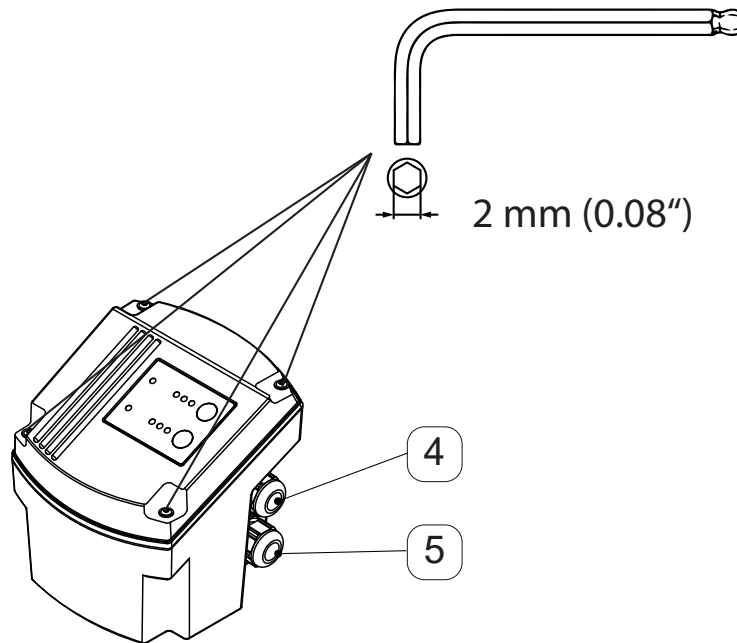

The hood of the control unit can subsequently be lifted off. Hereby ensure that the ribbon cable (3) will not be crushed or torn off.

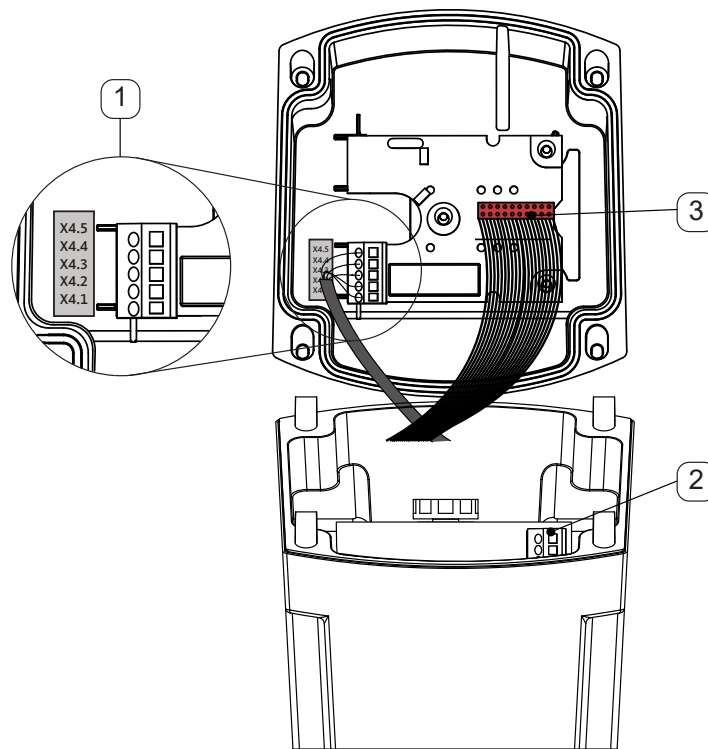

#### 4.5. Connection of voltage supply to the power control board

The voltage supply connection has been provided at the factory and is therefore no longer required. The terminal assignment is as follows:

- X1.1 = N / -
- X1.2 = L / +

#### 4.6. Connection of 4 ... 20 mA interfaces on the operating electronic printed circuit board

Utilising the 4 ... 20 mA interfaces will enable the issuing of the currently measured pressure dew point (depending on operating mode).

**4 mA  $\triangleq$  -48 °C**

**20 mA  $\triangleq$  +25 °C**

**Increments: 0.5 °C**

**Output value in case of error      24 mA**

The connection for the 4 ... 20 mA interface is implemented according to the following terminal assignment:

- X4.4 = - (empfohlen)
- X4.5 = + (empfohlen)

#### 4.7. Connection of equipotential contact to the operating electronic printed circuit board

An equipotential contact is available for issuing alarm signals. The connection for the equipotential contact is executed according to the following terminal assignment:

- X4.1 = n.o.
- X4.2 = com
- X4.3 = n.c.

## 5. Commissioning

After successful assembly in the pipework and the electrical installation the drying system can be put into operation. To do this, connect the power plug to the electrical power mains and slowly pressurise the pipework.

The red warning LED can illuminate at the beginning of commissioning as the device normally takes a few minutes to achieve the set degree for drying. Should the red warning LED continue to illuminate then refer to "Remedying malfunctions, errors, faults and troubleshooting" on Page 52.

## 6. Operation

### 6.1. Indicators in operation

This following represents both operating modes with their LED indicators. Red LED indicators indicate a fault in operation or a possible error. For additional information, refer to “Remedying malfunctions, errors, faults and troubleshooting” on Page 52.

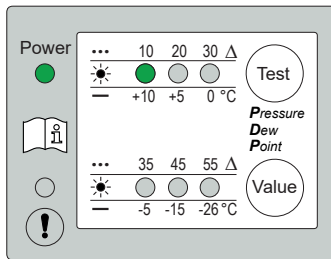

Power and value LED light up:  
**Constant mode**  
 → **DTP = +10 °C**  
 Power LED flashes (interval 2 sec.),  
 value LED lights up:  
**Dynamic mode** →  
**ΔT(DTP) = 10 K**

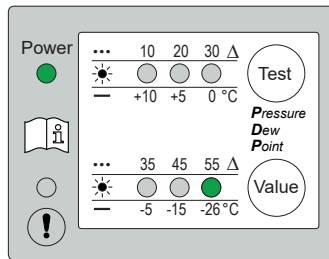

Power and value LED light up:  
**Constant mode**  
 → **DTP = -26 °C**  
 Power LED flashes (interval 2 sec.),  
 value LED lights up:  
**Dynamic mode** →  
**ΔT(DTP) = 55 K**

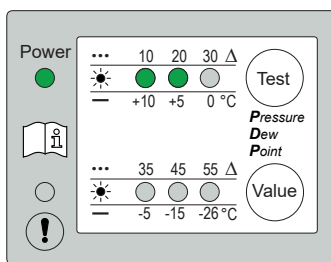

Power and value LED light up:  
**Constant mode**  
 → **DTP = +7 °C**  
 Power LED flashes (interval 2 sec.),  
 value LED lights up:  
**Dynamic mode** →  
**ΔT(DTP) = 15 K**

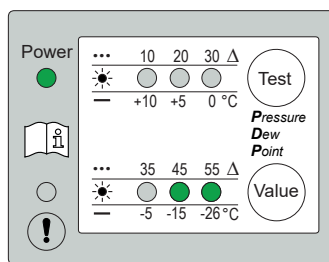

Power and value LED light up:  
**Constant mode**  
 → **DTP = -20 °C**  
 Power LED flashes (interval 2 sec.),  
 value LEDs light up:  
**Dynamic mode** →  
**ΔT(DTP) = 50 K**

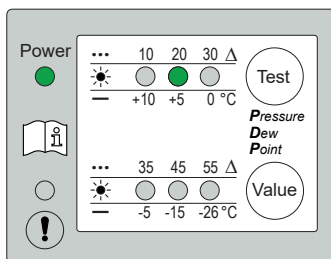

Power and value LED light up:  
**Constant mode**  
 → **DTP = +5 °C**  
 Power LED flashes (interval 2 sec.),  
 value LED lights up:  
**Dynamic mode** →  
**ΔT(DTP) = 20 K**

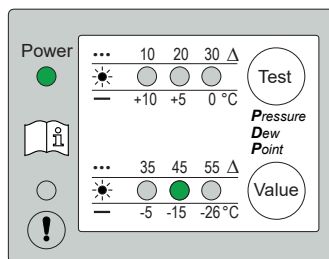

Power and value LED light up:  
**Constant mode**  
 → **DTP = -15 °C**  
 Power LED flashes (interval 2 sec.),  
 value LED lights up:  
**Dynamic mode** →  
**ΔT(DTP) = 45 K**

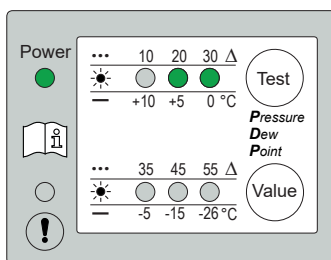

Power and value LED light up:  
**Constant mode**  
 → **DTP = +3 °C**  
 Power LED flashes (interval 2 sec.),  
 value LED lights up:  
**Dynamic mode** →  
**ΔT(DTP) = 25 K**

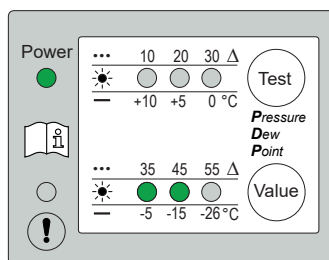

Power and value LED light up:  
**Constant mode**  
 → **DTP = -10 °C**  
 (factory settings)  
 Power LED flashes (interval 2 sec.),  
 value LED illuminates:  
**Dynamic mode** →  
**ΔT(DTP) = 40 K**

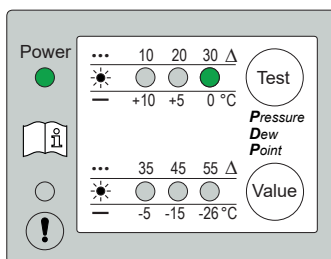

Power and value LED light up:  
**Constant mode** → **DTP = 0 °C**  
 Power LED flashes interval 2 sec.),  
 value LED lights up:  
**Dynamic mode** →  
**ΔT(DTP) = 30 K**

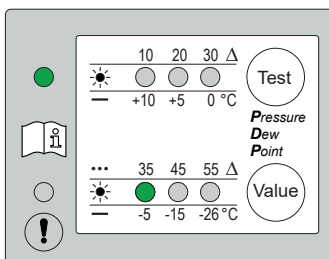

Power and value LED light up:  
**Constant mode**  
 → **DTP = -5 °C**  
 Power LED flashes (interval 2 sec.),  
 value LED lights up:  
**Dynamic mode** →  
**ΔT(DTP) = 35 K**



### 6.2. Solenoid valve test function

Pressing the >>Test<< button will control the solenoid valve and switches on 3 cycles for a length of 2 seconds.  
 Solenoid valve opened → Red LED off → complete purge air exits  
 Solenoid valve closed → Red LED on → only measuring gas exits

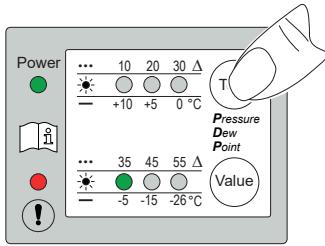

- Press and hold the >>Test<< button for 3 seconds
- Activation is displayed (all green LEDs flash)
- Release the >>Test<< button → valve switches for 3 cycles
- The system subsequently returns to normal operating mode.

### 6.3. Carrying out settings (set-up mode)

The software must be initially unlocked to be able to acquire settings. The unlocking is executed by simultaneously pressing the >>Value<< + >>Test<< buttons: All green LEDs flash to confirm activation.

You now have 10 seconds to acquire the settings. Every actuation of a button during this time span will result in the time span being available again for the complete duration.

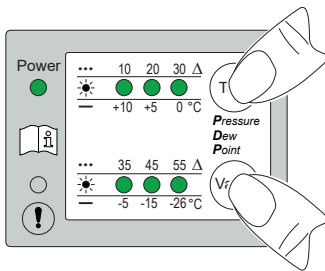

- Press >>Test<< + Taste >>Value<< button for 3 seconds
- Activation is displayed (all green LEDs flash)
- Release both buttons: Setup mode is activated
- Acquire amendments / settings

All settings apply until they are amended. Settings can be acquired via the >Value<< and >>Test<< buttons.

#### 6.3.1. Amend the operating mode

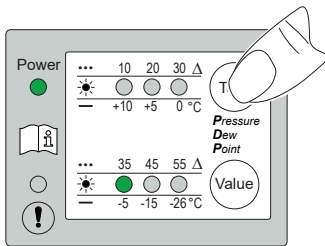

- Press the >>Test<< button. The power LED is lit permanently: **Constant mode**
- Power LED flashes (2 second cycle on-off) **Dynamic mode**

#### 6.3.2. Altering the values

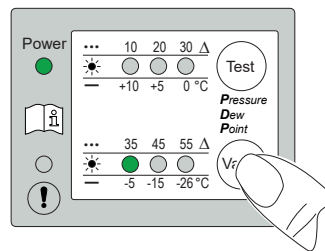

Press the >>Value<< button  
 1 value LED lights up:  
**35K / -5 °C (example)**

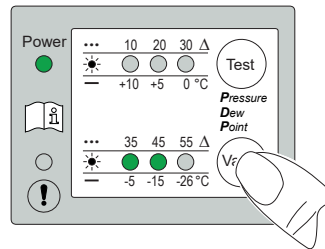

Press the >>Value<< button again  
 2 value LEDs light up:  
 Intermediate value  
**40K / -10 °C (example)**

Once the action or amendment has been finalised and no button has been pressed for a time period of 10 seconds, then the confirmation for finalising the action / acquisition of the amended values is executed: All green value LEDs flash. The system then transfers into normal mode and is controlled on the basis of the prescribed settings.

**6.3.3. Service mode**

This function can be utilised to acquire an inspection for the permeation rate on the membrane dryer during preventive service without having to dismantle the device. This inspection can determine whether this should be exchanged when necessary.

The control system must already be located in setup mode to utilise the service mode (Refer to 6.3). If the service mode is activated, then the solenoid valve will be closed permanently whereby only the measuring gas flow will flow through the control system.

This function can be manually deactivated again, otherwise the control system will automatically reset this function to normal mode after 30 seconds.

**Preparation:** Activate setup mode

- “6.3. Carrying out settings (set-up mode)” on Page 28
- Press >>Test<< and >>Value<< button for 3 seconds

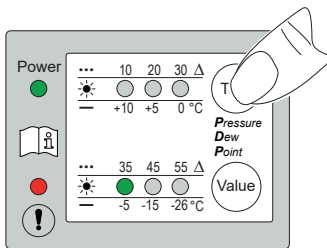

**Activating:**

- Press and hold the >>Test<< button for 10 seconds
- Activation is displayed (all green LEDs flash quickly)
- Release the >>Test<< button: Valve closes, only measuring gas flow flows

All green LEDs flash in a 2 second cycle during the service mode.

**Preparation:** Device is in service mode

(All green LEDs flash every 2 seconds.)

**Deactivating:**

- Press and hold the >>Test<< button for 10 seconds
- Activation is displayed (all green LEDs flash quickly)
- Release the button:  
Device goes back into setup mode: Changes can now be made to the settings.

If no button is actuated for longer than 10 seconds then the device returns to normal mode again.

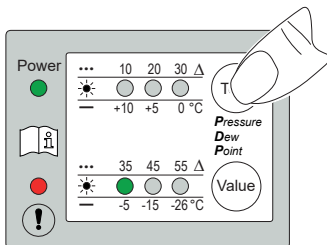

## 7. Maintenance and servicing

### 7.1. Maintenance schedule

Maintenance	Interval
<b>Function and visual inspection Refer to 7.1.1</b>	Regularly
<b>Replace the filter element and float drain Refer to 7.1.3</b> <ul style="list-style-type: none"> <li>• Exchange the filter element</li> <li>• Exchange the float drain</li> </ul>	annually
<b>Wear part exchange Refer to 7.1.4Refer to 7.1.4</b> <ul style="list-style-type: none"> <li>• Exchange of the wear parts</li> </ul>	Cycle: see “7.1.4. Wear part exchange” on Page 39

#### 7.1.1. Function and visual inspections

To ensure that the device is in proper working order, the system owner and/or operator must execute regular function and visual inspections:

- Inspect the device for trouble-free functionality  
purge air outlet, damage on the housing, leaks, defects on electrical connections
- Inspect the device for error indications  
→ For additional information refer to “9. Remedying malfunctions, errors, faults and troubleshooting” on Page 52
- Inspect the device for external soiling and contamination and clean if necessary  
→ For additional information refer to “Cleaning” on Page 50

7.1.2. Exchanging the control unit

Prerequisites		
Tools	Material	Protective equipment
<ul style="list-style-type: none"> <li>Allen key <math>\varnothing</math> 4 mm with <math>\geq</math> 100 mm shaft length</li> <li>Allen key <math>\varnothing</math> 2 mm</li> </ul>	<ul style="list-style-type: none"> <li>none</li> </ul>	<ul style="list-style-type: none"> <li>None</li> </ul>

Preparatory tasks	
1.	Depressurise the device and secure against pressure being applied again.
2.	De-energise the device and secure it against being switched back on again. Remove the mains plug. →A “click” noise indicates the opening of the solenoid valve. → Pressure drop is taking place in the device.

Description	Illustration
1. Unscrew the screws from the hood of the control unit using an Allen key. Remove screws.	
2. Open the hood of the control unit carefully to the left. Route the ribbon cable to the left out of the cable run.	
3. Remove the fixing screws and washers for the membrane dryer head.	

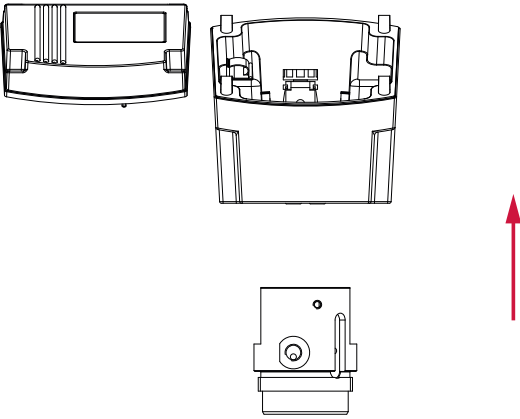
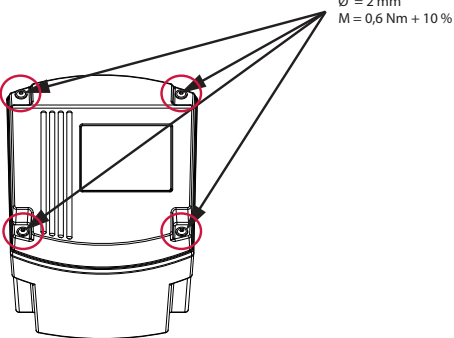
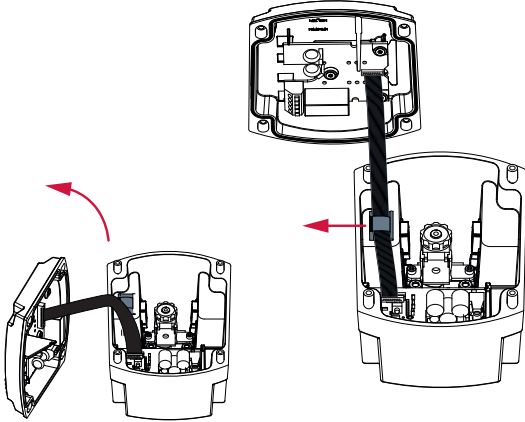
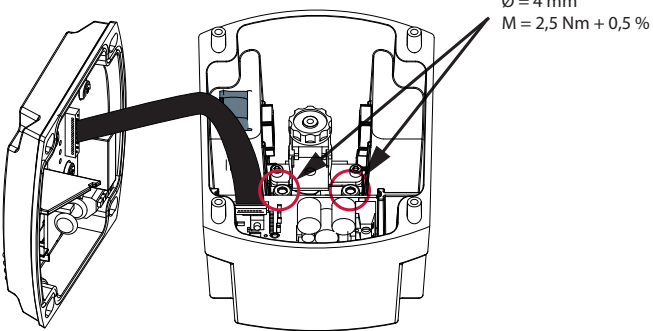
<p>4. Lift the control unit off the membrane dryer head.</p>	
<p>5. Unscrew the screws from the hood of the new control unit using an Allen key.</p>	
<p>6. Open the hood of the control unit carefully to the left. Route the ribbon cable to the left out of the cable run.</p>	
<p>7. Insert washers and fixing screws for the membrane dryer head.</p>	



8. Insert the O-rings into the housing bottom.  
Secure O-rings against slipping or falling out.

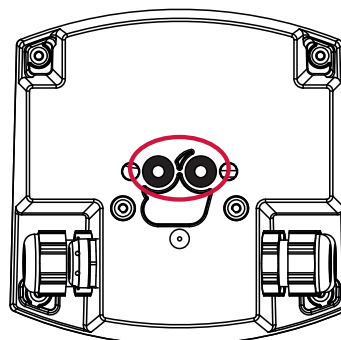

9. Place the control unit on the (DRYPOINT® M) housing.

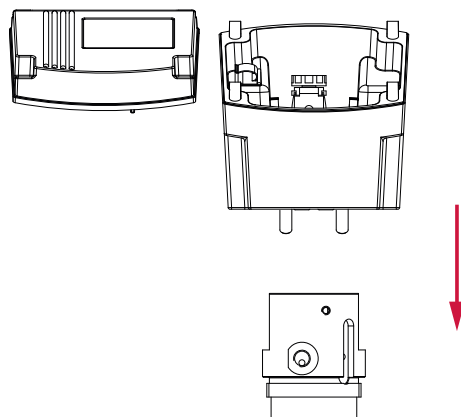

10. Tighten the fixing screws with washers for the membrane dryer head using an Allen key.

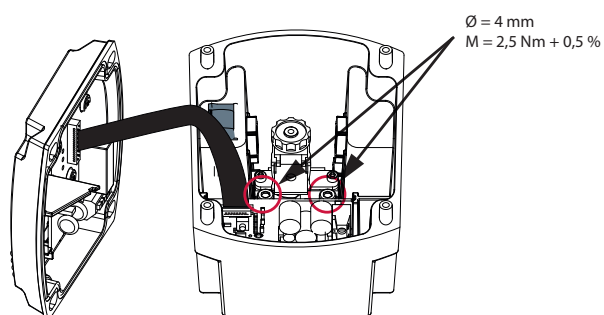

11. Check the housing seal for a correct fit in the hood groove.

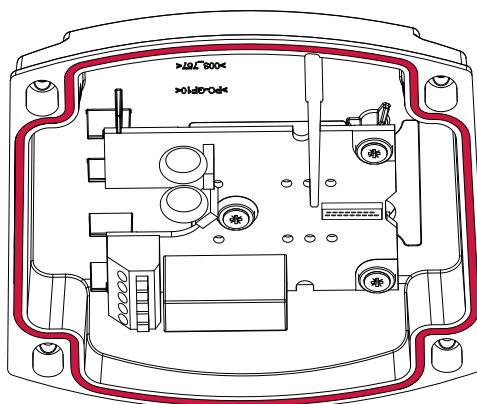

12. Route the ribbon cable to the right into the cable run and carefully close the hood of the control unit to the right.

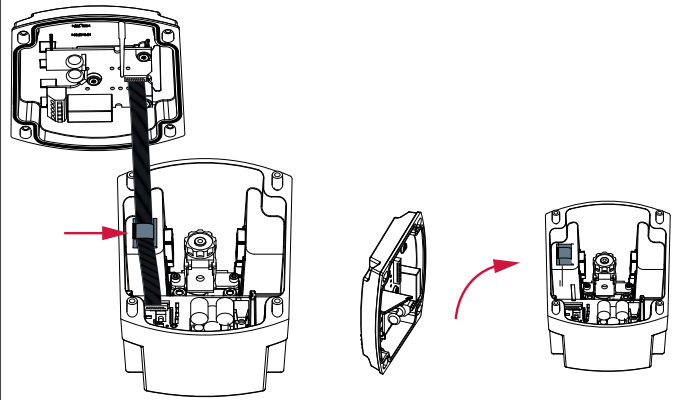



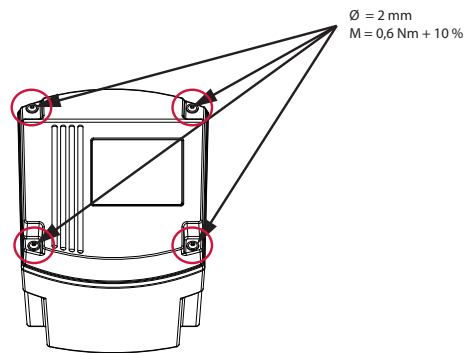

13. Tighten the screws for the hood of the control unit using an Allen key.



**7.1.3. Replace the filter element and float drain**

Exchange the filter element and the float drain once every year in accordance with the maintenance schedule. Further information about exchanging spare parts is included on a leaflet with the spare parts.

Prerequisites		
Tools	Material	Protective equipment
<ul style="list-style-type: none"> <li>• Mounting tool</li> </ul> 	<ul style="list-style-type: none"> <li>• Filter element</li> </ul>  <ul style="list-style-type: none"> <li>• Float drain</li> </ul> 	

Preparatory tasks	
1.	Depressurise the device and secure against pressure being applied again:
2.	De-energise the device and secure it against being switched back on again. Remove the mains plug. →A “click” noise indicates the opening of the solenoid valve. → Pressure drop is taking place in the device.

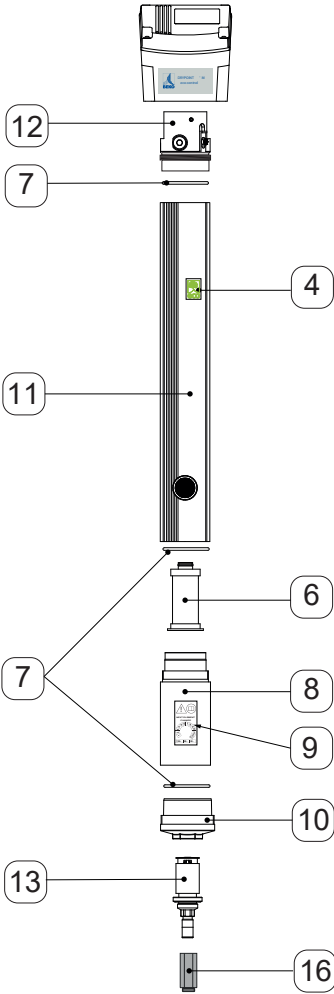
Maintenance work	
	[4] Eco label
	[6] Filter element
	[7] O-rings (housing)
	[8] Housing extension
	[9] Maintenance label: Filter replacement
	[10] Housing base
	[11] Housing body with membrane element
	[12] Membrane dryer head
	[13] Float drain
	[16] Mounting tool for float drain

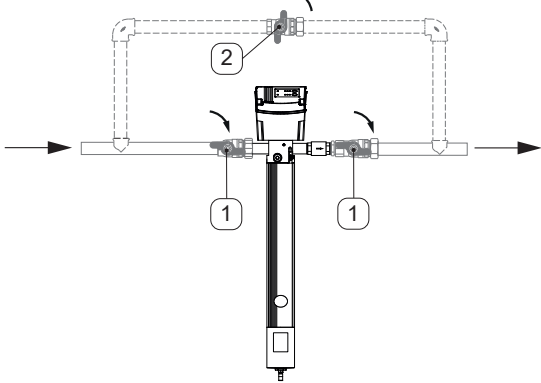
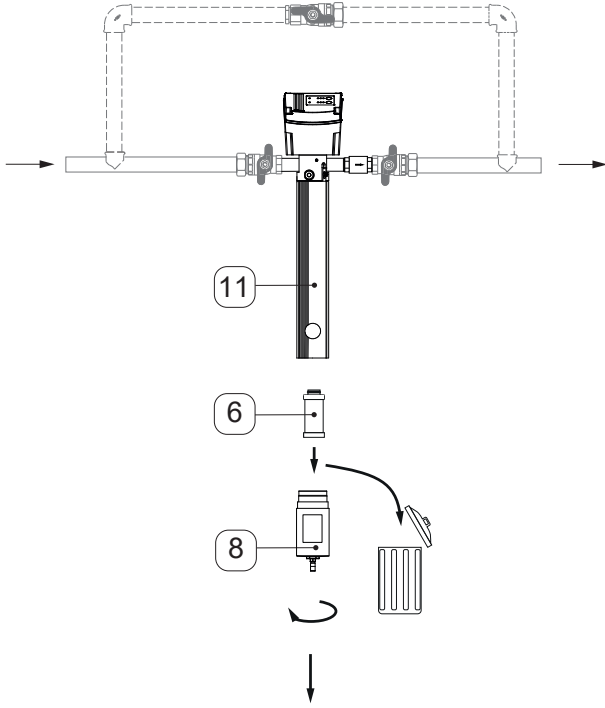
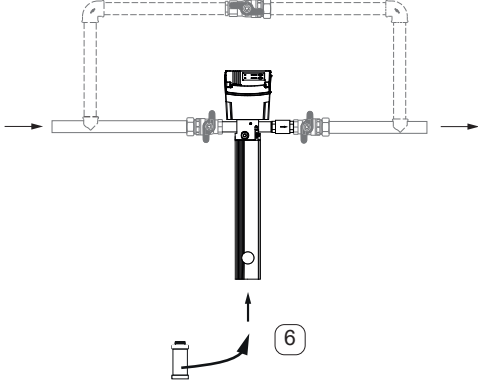
	<ol style="list-style-type: none"> <li>1. Open the shut-off valve [2] of the bypass pipe.</li> <li>2. Close the shut-off valves [1].</li> </ol>
	<ol style="list-style-type: none"> <li>3. Hold the top part of the housing [11] tight, screw the housing extension [8] off.</li> <li>4. Remove housing extension [8].</li> </ol> <p><b>NOTE</b> <b>Proper disposal!</b></p> <p>Inappropriate disposal of parts and components, operating and auxiliary materials as well as cleaning media can cause environmental damage.</p> <ul style="list-style-type: none"> <li>• Dispose of all parts and components, operating and auxiliary materials as well as cleaning media professionally and in accordance with regional legal provisions, regulations and requirements.</li> <li>• In case of uncertainties regarding disposal, always consult a regional waste management company.</li> </ul> <ol style="list-style-type: none"> <li>5. Remove the filter element [6] from the housing [11].</li> <li>6. Dispose of used filter element [6] properly.</li> </ol> <p>For additional information refer to “6. Dismantling and disposal”, on Page 32.</p>
	<ol style="list-style-type: none"> <li>7. Insert the new filter element [6] into the housing.</li> </ol>

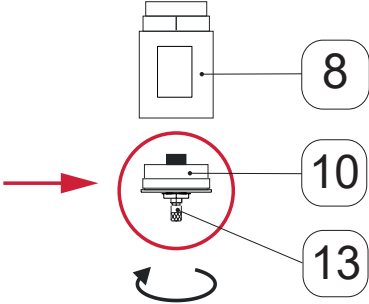
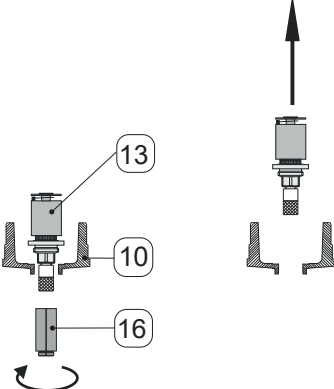
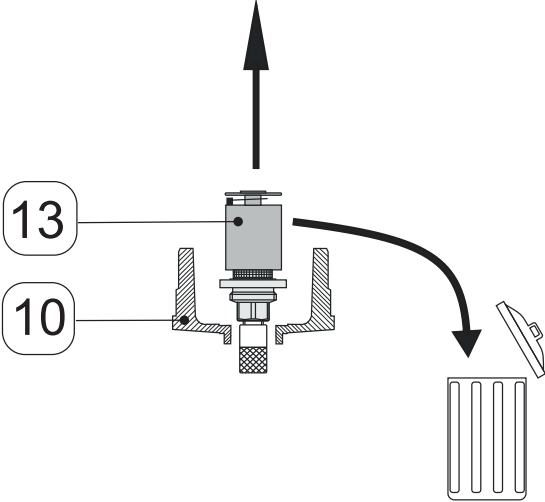
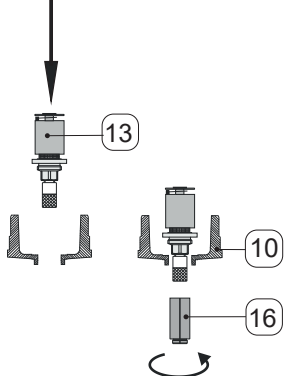
	<p>8. Screw the housing base [10] with float drain [13] out of the housing extension [8].</p>
	<p>9. Use the mounting tool [16] to screw the float drain [13] out of the housing base [10].</p>
	<p><b>NOTE</b></p> <p><b>Proper disposal!</b></p> <p>Inappropriate disposal of parts and components, operating and auxiliary materials as well as cleaning media can cause environmental damage.</p> <ul style="list-style-type: none"><li>• Dispose of all parts and components, operating and auxiliary materials as well as cleaning media professionally and in accordance with regional legal provisions, regulations and requirements.</li><li>• In case of uncertainties regarding disposal, always consult a regional waste management company.</li></ul> <p>10. Pull the float drain [13] up and out of the housing base [10] and dispose of it properly.</p>
	<p>11. Insert a new float drain [13] into the housing base [10] from above.</p> <p>12. Use the mounting tool [16] to screw the float drain [13] tight in the housing base [10].</p>

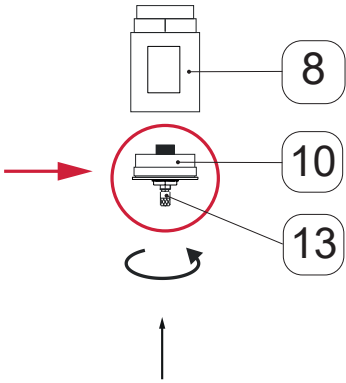
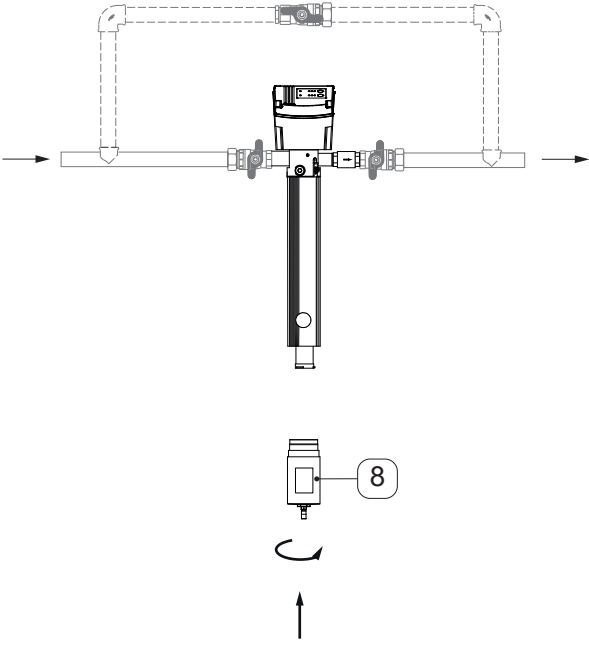
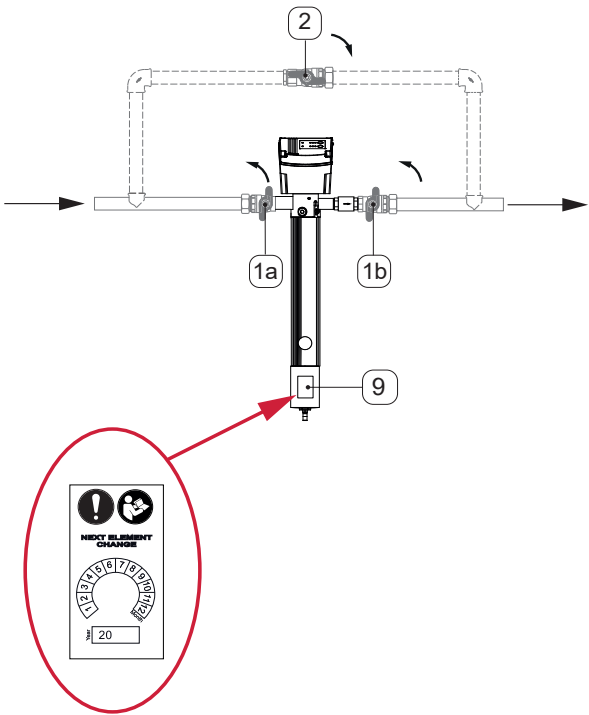
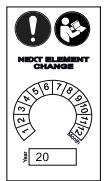
	<p>13. Screw the housing base [10] with float drain [13] into the housing extension [8].</p>
	<p>14. Screw the housing extension [8] with float drain onto the housing [12].</p>
 <div data-bbox="159 1646 343 1937" style="border: 2px solid red; border-radius: 50%; padding: 10px; width: fit-content;">  </div>	<p>15. Attach a new maintenance sticker [9] on the housing extension [8].          → Mark when the next maintenance is due.</p> <p>16. Slowly open the shut-off valves [1a].          17. Slowly open the shut-off valve [1b].          18. Close the shut-off valve [2] on the bypass pipe.</p>

**Concluding work**

- |    |   |
|----|---|
| 1. | Plug the device back in to the voltage supply.                      |
| 2. | Carry out commissioning, see chapter “5. Commissioning” on Page 26. |

#### 7.1.4. Wear part exchange

The device includes a solenoid valve and a piston valve whose seals are dynamically stressed; they are subject to wear and must therefore be exchanged cyclical.

The service life of these parts is many million switchings, however, it depends strongly on the actual runtime of the plant and possibly also on the air contaminants.

The following values are listed as guide values for the preventive maintenance:

- Single shift operation (260 work days/year) → average service life 2 years
- Continuous operation 24/7 → average service life 1 year

The normal wear at these parts - surface abrasion or deformations at the seat areas - has no impact on the function.

The full purge air volume flows continuously and the control function has no impact if the wear of the seals is too large or if the seals are destroyed, e.g. due to the impact of aggressive compressed air ingredients or significant ageing.

This system condition is not detected by the device as a failure (red LED not lit) because the requirements for the set degree of drying are fulfilled.

A required exchange of the wear parts during the warranty period does therefore not establish a warranty claim, but it represents normal maintenance effort.

Please contact the service of **BEKO TECHNOLOGIES GmbH** if maintenance cycles are required significantly more often for specific applications/installations.

Prerequisites		
Tools	Material	Protective equipment
<ul style="list-style-type: none"> <li>• Allen key Ø 2 mm</li> <li>• Allen key Ø 2.5 mm with ≥ 100 mm shaft length</li> <li>• Allen key Ø 4 mm with ≥ 100 mm shaft length</li> </ul>	<ul style="list-style-type: none"> <li>• Set of wear parts → 4040729</li> <li>• 4041283</li> </ul>	<ul style="list-style-type: none"> <li>• None</li> </ul>

Preparatory tasks	
1.	Depressurise the device and secure against pressure being applied again:
2.	De-energise the device and secure it against being switched back on again. Remove the mains plug. →A “click” noise indicates the opening of the solenoid valve. → Pressure drop is taking place in the device.
3.	Prepare workplace for the exchange of the wear parts.

NOTE	Damages possible
	Damages of the device or the electronic printed circuit board as well as crushing or breakage of cables can occur during the wear part exchange.
	<ul style="list-style-type: none"> <li>• While working, prevent the development of mechanical tensions, which can damage the electronic printed circuit board or the cables.</li> </ul>

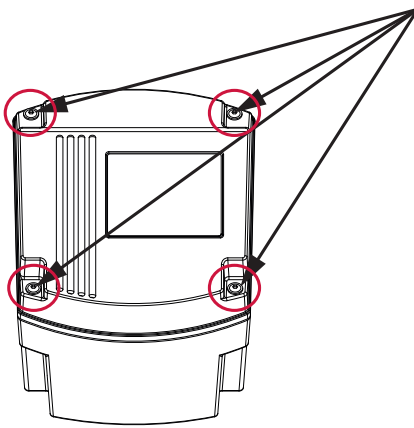
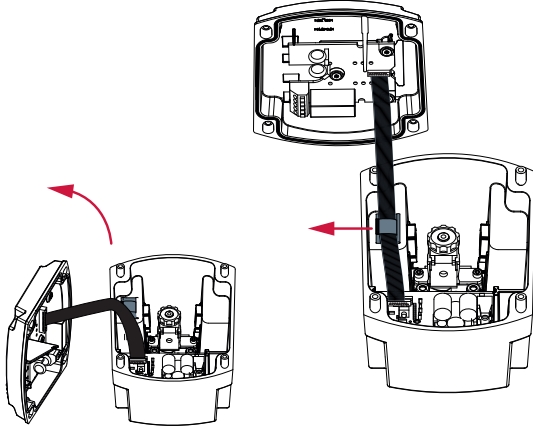
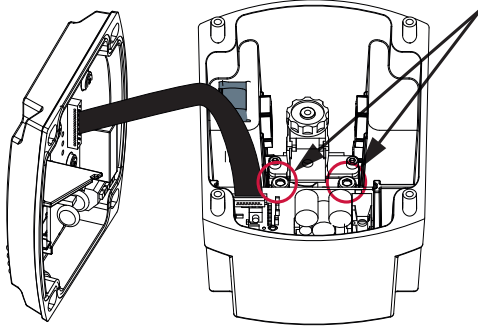
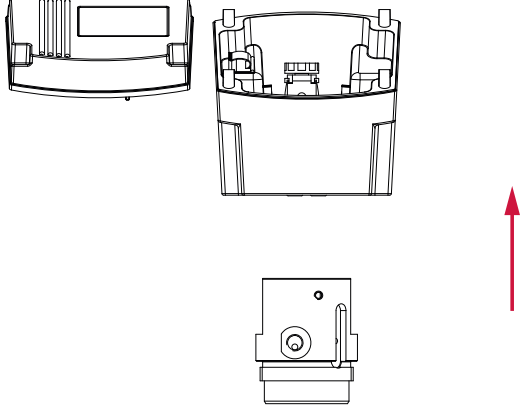
Description	Illustration
<p>1. Unscrew the screws from the hood of the control unit using an Allen key. Remove screws.</p>	 <p><math>\varnothing = 2 \text{ mm}</math> <math>M = 0,6 \text{ Nm} + 10 \%</math></p>
<p>2. Open the hood of the control unit carefully to the left. Route the ribbon cable to the left out of the cable run.</p>	
<p>3. Undo the fixing screws and washers for the membrane dryer head using an Allen key and remove them.</p>	 <p><math>\varnothing = 4 \text{ mm}</math> <math>M = 2,5 \text{ Nm} + 0,5 \%</math></p>
<p>4. Lift the control unit and perform the following work at a clean work place.</p>	



5. Undo the armoured conduit fitting (1) on the cable throughout to the housing.  
Push the cable (2) a few centimetres into the housing.

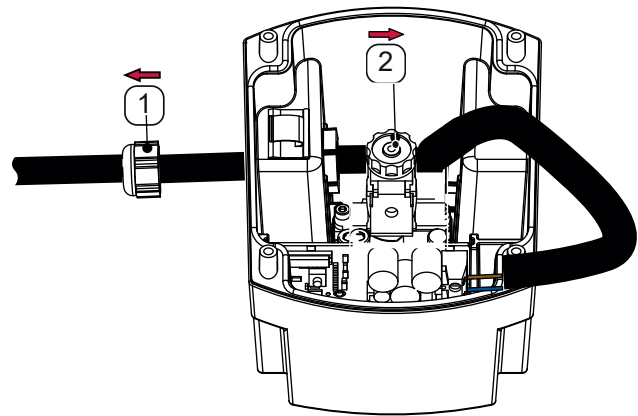

6. Unscrew the knurled nut of the solenoid coil.

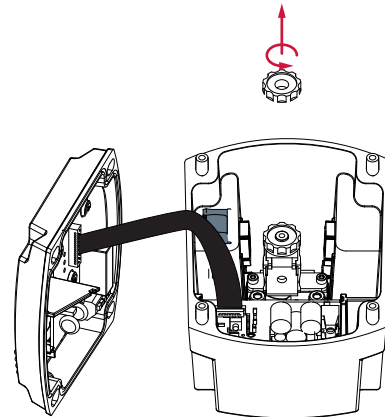

7. Remove the solenoid coil, rotate by 180° and hang across the housing of the control unit.

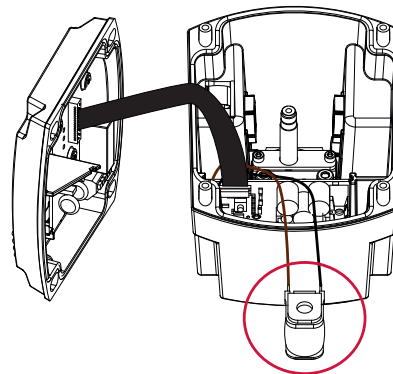

8. Carefully pull the electronic printed circuit board up and out of the guide.

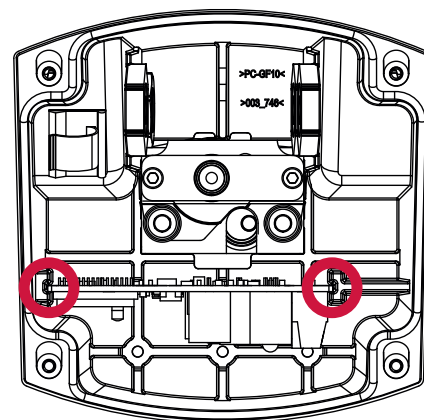

9. Hang the electronic printed circuit board carefully over the housing edge by the cables.

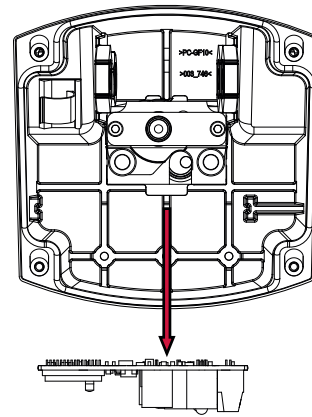

10. Replace the solenoid coil:

- Use pointed pliers to pull the connector out parallel to the surface of the electronic printed circuit board.
- Consequences of non-compliance:  
Damage to the plug connection possible.  
Only hold the electronic printed circuit board by the narrow edges.

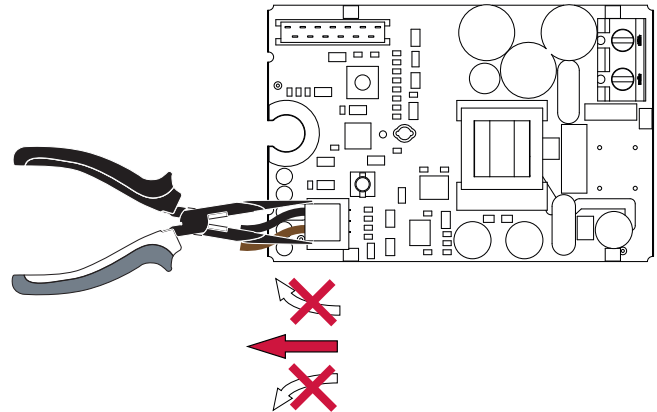

11. Replace the solenoid coil.

Insert the new connector onto the pins as far as it will go parallel to the surface of the electronic printed circuit board.

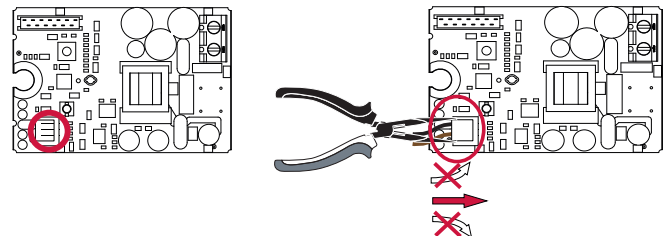

12. Loosen the screws on the pilot valve seat using an Allen key.

The pilot valve seat is raised upwards by the force of the spring underneath it.

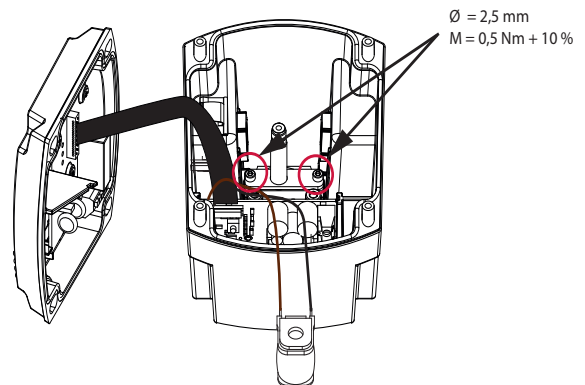

13. Remove the pilot valve seat with the core guide pipe and the screws.

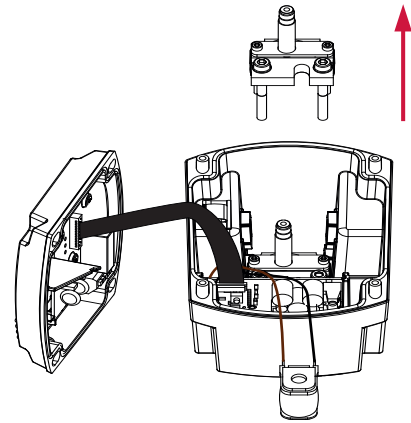

14. Replacement of the anchor system comprising magnetic core guide pipe and core:

- Remove the core guide pipe and core with the retaining plate.
- Pull the anchor system down and out of the retaining plate.

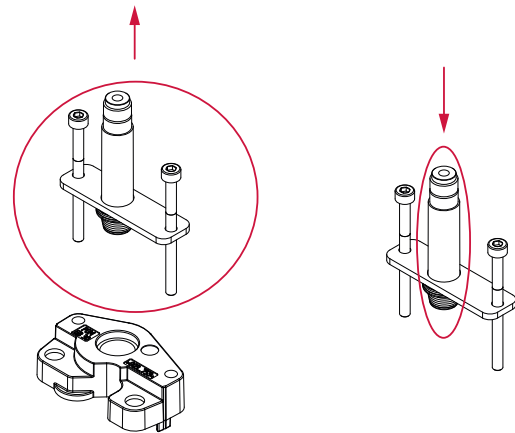

15. Insert a new anchor system into the retaining plate from below.  
Set the core guide pipe onto the pilot valve seat.

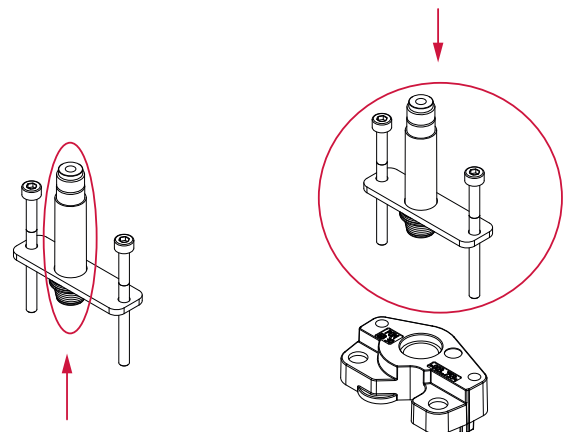

16. Remove switch-over valve seat, rotate by 180° and place in front of the control unit.

- Remove the piston with spring and seal from the switch-over valve seat.

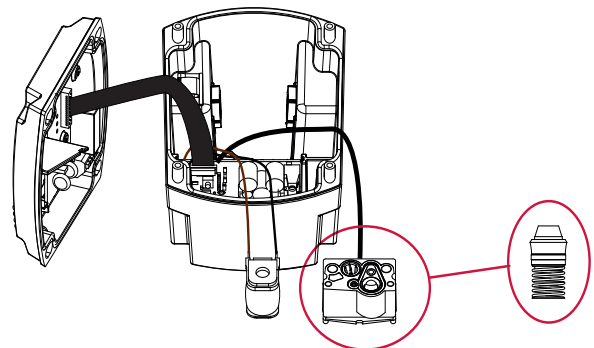

17. Exchange the seal at the switch-over valve seat.  
Check the seal for correct position in the groove.

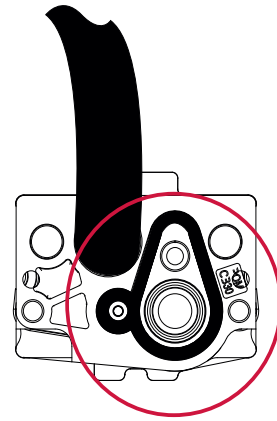

18. Remove the seal in the housing and insert a new one.  
Check the seal for correct position in the groove.

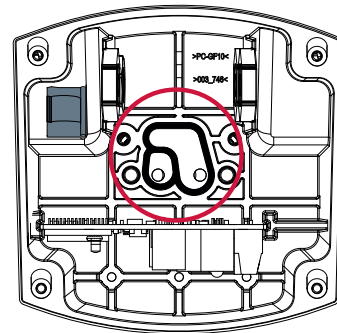

19. Insert the switch-over valve seat into the control unit:

- Seal is at the top.
- The raster is pointing downwards.

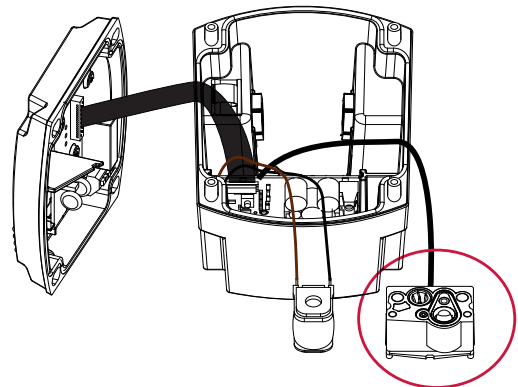

20. Insert the new piston and spring into the switch-over valve seat:

- Insert the spring in the switch-over valve seat.
- Set the new piston onto the spring with the sealing face facing downwards.

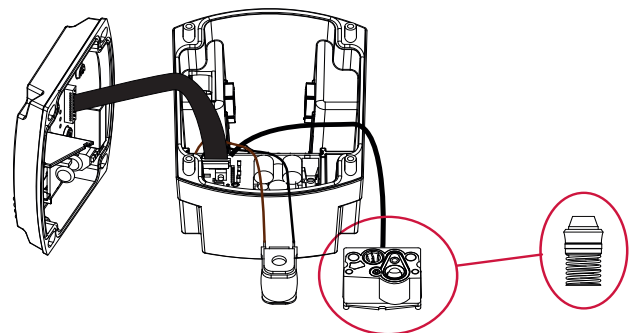

21. Insert the pilot valve seat and press down slightly against the spring pressure.

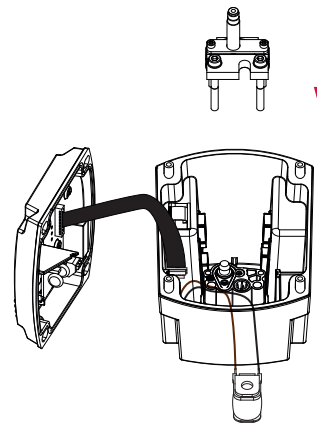

22. Fasten the upper screws into place on the pilot valve seat.

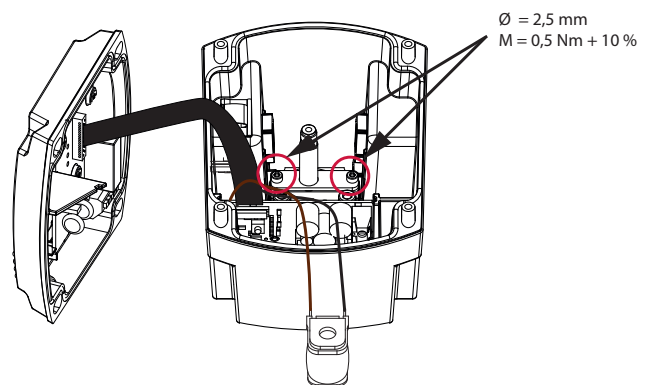

23. Turn the solenoid coil through 180°, set onto the core guide pipe (coil connections are at the top) and screw tightly using the knurled screw.

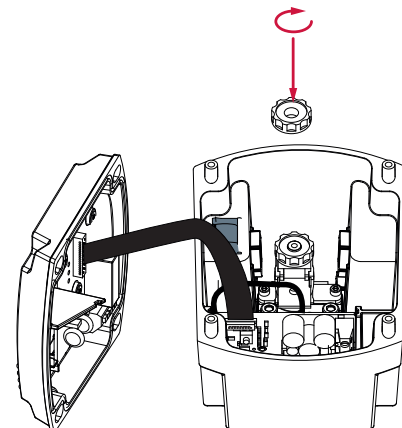

24. Route the coil cables through the recess in the electronic printed circuit board when inserting the electronic printed circuit board. Place all cables without bending or crushing in the free spaces when inserting the electronic printed circuit board.

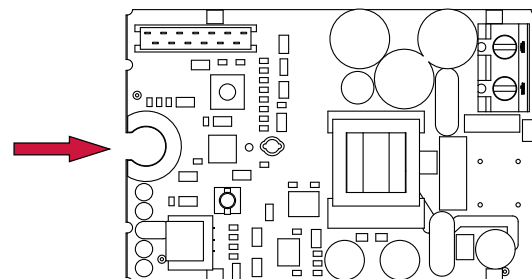

25. Insert the electronic printed circuit board into the guide. The electronic printed circuit board can be inserted easily into the grooves. If there is any canting in the guide, remove the electronic printed circuit board and insert it again with caution.

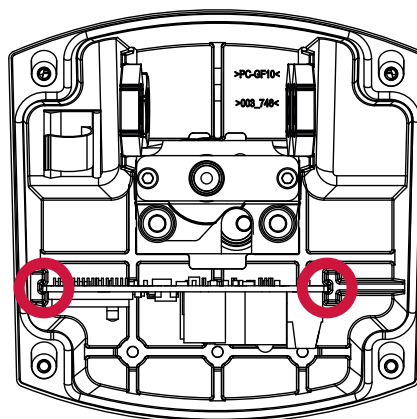

26. Push the mains cable (1) back through the opening with the armoured conduit fitting (2) to the outside.

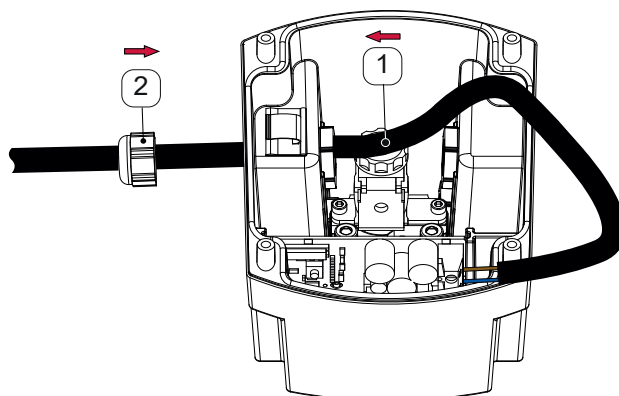

27. Only push the excess cable (2) out so far that the cable connection at the electronic printed circuit board is not under tension. Tighten the armoured conduit fitting (1).

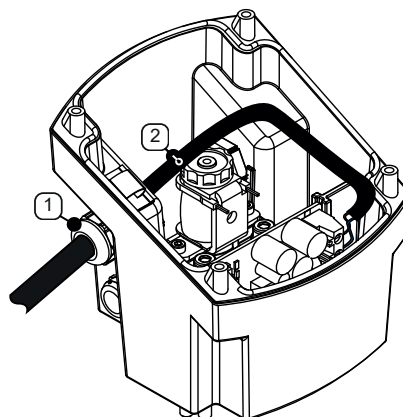

28. Insert the O-rings into the housing bottom. Secure O-rings against slipping or falling out.

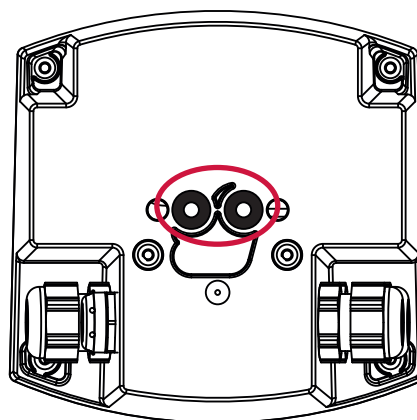

29. Place the control unit on the membrane dryer head (**DRYPOINT® M**).

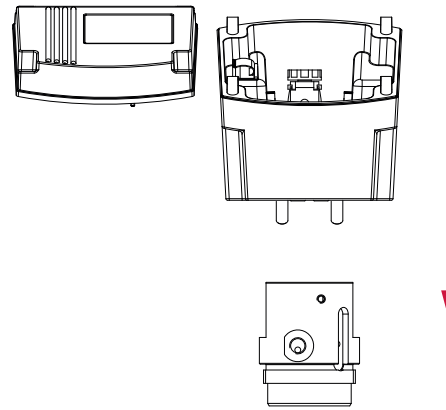

30. Tighten the fixing screws with washers for the membrane dryer head using an Allen key.

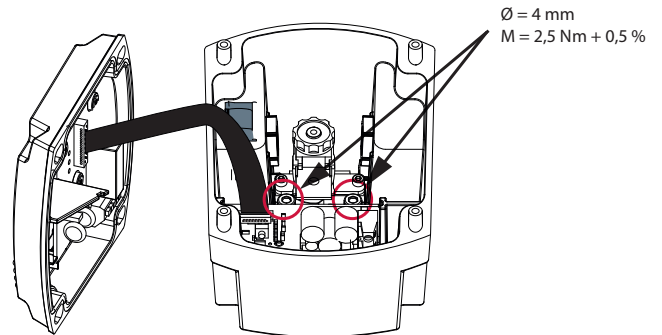

31. Replace the cord packing in the hood and check for correct position in the groove.

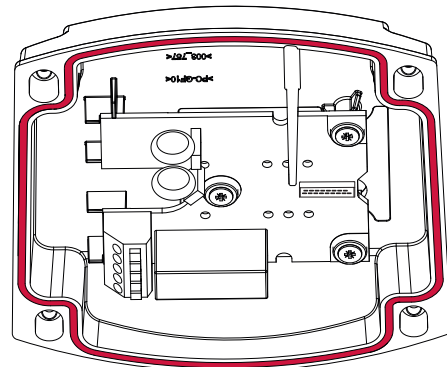

32. Route the ribbon cable to the right into the cable run and carefully close the hood of the control unit to the right.

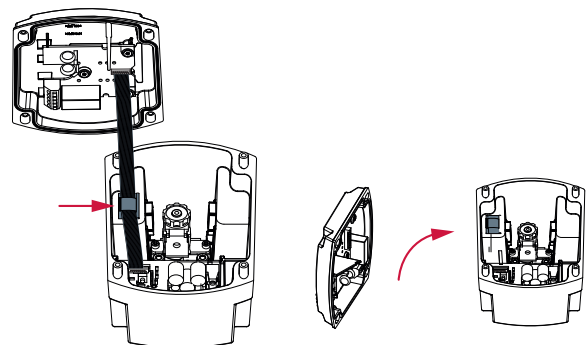

33. Tighten the screws for the hood of the control unit using an Allen key.

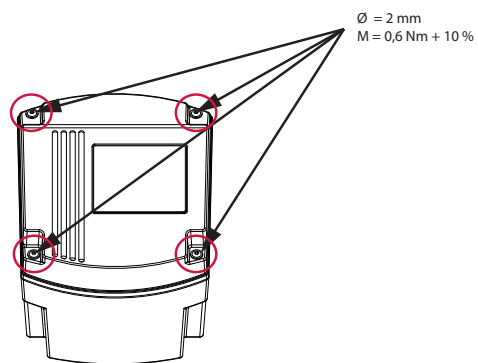

#### Concluding work

- |    |   |
|----|---|
| 1. | Plug the device back in to the voltage supply.                      |
| 2. | Carry out commissioning, see chapter "5. Commissioning" on Page 26. |



### 7.1.5. Measuring the permeation rate

<b>NOTE</b>	<b>The device is subject to working pressure and energised</b>
	<p>The device is subject to working pressure and energised during the execution of maintenance works</p> <ul style="list-style-type: none"> <li>• Only the following described activities</li> </ul>

The following prerequisites must be created for measuring the permeation rate – as a status evaluation for the membrane itself:

- Procure a suitable volume flow measuring device in the range 10 – 100 l/minute (atmospheric) with connection connecting hose (approx. 1 m) / plug-in connector with connection thread G1/4
- Set the **DRYPOINT® M eco control** to “Service mode”, Refer to 6.3.3 (the device interior is only provided with measuring gas flow)

#### Measuring process:

- Screw out the blind plugs on the membrane dryer head
- Exiting purge air is reduced to depressurised
- Screw in the connector G1/4 from the hose connection volume flow of the measuring device in the thread G1/4 in the head
- Hold close / adhere the purge air outlets
- Read out the measurement results

The connection in the head of the membrane dryer must be sealed again with the blind plugs after the measuring process and the purge air outlet on the screen must be freed again. Subsequently reset the device in normal mode (Refer to 6.3.3.)

Recommended limit value in l/min: approx. 25% of the maximum purge air volume for **DRYPOINT® M eco control** plus 5 l/min (share of measuring gas flow).

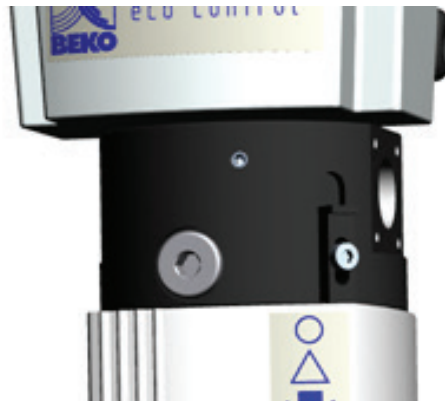





### 7.1.6. Cleaning

NOTE	Damage to device caused by improper cleaning
	Cleaning with a wet cloth, hard or pointed implement or aggressive detergent can damage the components and integrated electronic components.
	<ul style="list-style-type: none"><li>• Never clean the device with a dripping wet cloth.</li><li>• Do not use aggressive detergents.</li><li>• Never clean the device with hard or pointed implements.</li></ul>

The **DRYPOINT® M eco control** is cleaned with a damp (not wet) cotton or disposable cloth as well as mild, commercially available cleaning agent / soap.

Spray a little detergent onto the clean cotton cloth or disposable cloth and carefully wipe the component. Dry the device subsequently with a clean cloth or let it dry at room temperature. Observe all hygiene instructions applicable on the site.

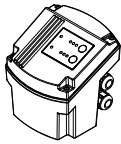
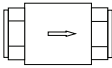
## 8. Spare parts and accessories

Type	Spare part	Illustration	Order ref.
DEC 1 + DEC 2	Filter element		4007268
DEC 3 - DEC 6			4010849
DEC 7 - DEC 9			4009150
DEC 1 + DEC 2	Float drain		4025537
DEC 3 - DEC 6			
DEC 7 - DEC 9			
DEC 1 + DEC 2	Control unit		See type plate
DEC 3 - DEC 6			
DEC 7 - DEC 9			
DEC 1 + DEC 2	Check valve G1/2		On request
DEC 3 - DEC 6	Check valve G1/2		On request
DEC 7 - DEC 9	Check valve G1		On request
DEC 1 - DEC 9	Set of wear parts 1	Piston valve with seals and pressure spring 4, 16, 17, 18, 22, 31	4040729
DEC 1 - DEC 9	Set of wear parts 2	Solenoid coil, knurled screw and cord packing	4041283
DEC 1 - DEC 9	Set of spare parts	Solenoid valve, complete, with anchor system and cable 150 mm 4, 10, 11, 14	4042549
DEC 1 - DEC 9	Set of spare parts	Anchor system: Magnetic core with magnetic core guide tube 4, 14	4042547
DEC 1 - DEC 9	Membrane element, sealed in the housing body • 12		On request

## 9. Remediating malfunctions, errors, faults and troubleshooting

### 9.1. Behaviour in the event of malfunctions/errors, faults

Errors and faults in the functions or damages should be compared with the possible following listed cause of errors in the FAQ section. If necessary, contact the manufacturer for advice.

#### 9.1.1. Failure of the voltage supply

In the event of a voltage supply failure, the solenoid valve opens so that the purge air flow is unrestricted. As soon as the voltage supply has been restored, the **DRYPOINT® M eco control** returns to normal mode with the previously applicable settings.

#### 9.1.2. Sensor failure

The sensor detects the failure or the fault by the sensor: red LED is lit permanently

- Power LED: continuously shows the operating mode
- Value LEDs: continuously show the set value

9.1.3. Deviating degree of drying

If a deviation from the set point pressure dew point is identified during operation, then this will be indicated. The permissible deviations can be found in the following tables.

Specifications

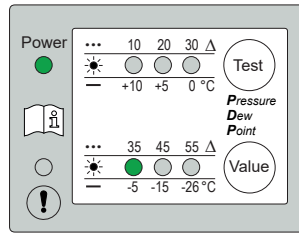

Set point = 35 K / -5 °C  
(example)

Exceeding upper permissible deviation

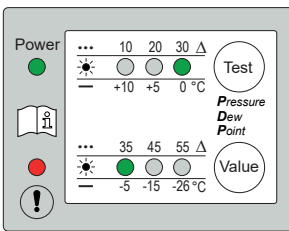

Value LED lights up:  
Set point = 35 K / -5 °C  
(example)

Value LED of higher value next to the setting flashes:  
Value = 30 K / 0 °C (example)

Red LED flashes  
(interval 2 seconds)

Undershooting lower permissible deviation

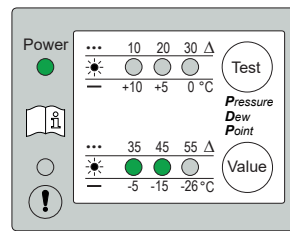

Value LED lights up:  
Set point = 35 K / -5 °C  
(example)

Value LED of lower value next to the setting flashes:  
Value = 45 K / -15 °C (example)

If the achieved pressure dew point once again complies with the set point value, then the normal operating mode will commence again.

Exceeding: Limit value for activating the error/fault message with too little drying

Set point pressure dew point	Permissible upper limit	Flashing value LED
≥ +3 °C	+4.5 °C	+10 °C
≥ 0 °C	+4.5 °C	+5 °C
≥ -10 °C	+7.5 °C	0 °C
≥ -20 °C	+7.5 °C	-5 °C
< -20 °C	+10.5 °C	-15 °C

Undershooting: Limit value for indicating too strong drying

Set point pressure dew point	Permissible lower limit	Flashing value LED
≥ +10 °C	-4.5 °C	+5 °C
≥ +5 °C	-4.5 °C	0 °C
≥ +3 °C	-4.5 °C	-5 °C
≥ 0 °C	-7.5 °C	-5 °C
≥ -5 °C	-7.5 °C	-15 °C
≥ -15 °C	-7.5 °C	-26 °C
< -15 °C	-10.5 °C	-26 °C

## 9.2. FAQ

Error or fault pattern	Possible causes	Remedy
<b>Poor degree of drying</b>	Temporary overload	Improve the operating conditions e.g. increased working pressure, prevent sudden load changes
	Incorrect dimensioning	Implement larger dryer
	Aerosol ingress	Inspect filter element function and, where applicable, exchange it or introduce an additional preliminary filter; inspect condensate drain-off function and replace it if necessary
	Purge air flow blocked internally	Contact manufacturer: If necessary, return device for repair
	Sensor is too old	Contact manufacturer: If necessary, return device for repair and/or replace control unit
	Incorrect operating mode selected	Amend the operating mode
	Coating formation on the sensor caused by low quality of the flowing in air	<ul style="list-style-type: none"> <li>• Improve compressed air quality on membrane dryer inlet</li> <li>• Adhere to the filter element maintenance interval and replace the element regularly</li> <li>• Exchange control unit</li> <li>• Return the device to the manufacturer for repair</li> </ul>
<b>Purge air outlet is always open ("fail-safe")</b>	Continuous overload	Improve operating conditions e.g. increase working pressure, avoid sudden load changes; check dryer dimensions; use larger unit
	Fail-safe mode active	Inspect error and fault messages: The flashing rate of the red LED indicates the type of the fault; if necessary, contact manufacturer
	Incorrect installation direction	Inspect installation direction of device
	Software error	Contact manufacturer: If necessary, return device for repair and/or replace control unit
	Sensor defective	Contact manufacturer: If necessary, return device for repair and/or replace control unit
	Power failure (power LED off)	Reconnect to the voltage supply
	Power control board defective	Contact manufacturer: If necessary, return device for repair and/or replace control unit
	Device overheating	The device automatically resumes its operating state when the internal temperature has dropped < 60°C
	Piston seal defect	Replace set of wear parts, see chapter "7.1.4. Wear part exchange" on Page 39
	Measuring gas jet is blocked	Contact manufacturer: If necessary, return device for repair and/or replace control unit
Solenoid coil burnt through	Change solenoid coil, see chapter "7.1.4. Wear part exchange" on Page 39	
<b>Purge air outlet constantly closed (measuring gas flow only)</b>	Incorrectly dimensioned unit	Use smaller dryer
	Sensor defective	Contact manufacturer: Return device for repair and/or replace control unit

Error or fault pattern	Possible causes	Remedy
<b>Fault signal upon switching on device</b>	Required performance parameters not yet reached	The moment the set performance range is reached, the error message is automatically reset (latest after 10 to 15 minutes) → otherwise, identify cause of the problem: The flashing rate of the red LED indicates the type of the fault; if necessary, contact manufacturer
	Electronic printed circuit board fault	Contact manufacturer: Return device for repair and/or replace control unit
<b>Settings cannot be changed</b>	Both buttons not pressed simultaneously	See chapter ... Operation: Correct button operation, testing with solenoid valve
	Button not held long enough	See chapter ... Operation: Press the buttons for approx. 0.2 sec.
	Button physically damaged	Contact manufacturer: Return device for repair and/or replace control unit
<b>No power supply (green "Power" LED is not lit)</b>	Incorrect voltage supply	Check the voltage supply to ensure that it corresponds to that specified on the type plate
	Electronic printed circuit board fault	Contact manufacturer: Return device for repair and/or replace control unit
	Device overheating	The device automatically resumes its operating state when the internal temperature has dropped < 60°C

## 10. Decommissioning

Preparatory tasks	
1.	Depressurise the device and secure against pressure being applied again.
2.	De-energise the device and secure it against being switched back on again. Remove the mains plug. →A “click” noise indicates the opening of the solenoid valve., which makes pressure drop in the device possible.

If only the mains voltage supply is interrupted, then the drying system will continue to operate in fail-safe mode. This means that the entire purge air volume will be continuously consumed.



## 11. Dismantling and disposal

### 11.1. Warning notices

NOTE	Inappropriate disposal!
	<p>Inappropriate disposal of parts and components, operating and auxiliary materials as well as cleaning media can cause environmental damage.</p> <ul style="list-style-type: none"> <li>• Dispose of all parts and components, operating and auxiliary materials as well as cleaning media professionally and in accordance with regional legal provisions, regulations and requirements.</li> <li>• In case of uncertainties regarding disposal, always consult a regional waste management company.</li> </ul>

At the end of its useful life, the product must be disposed of properly e.g. by a specialist company. Materials such as glass, plastics and some chemical compounds are mostly recoverable, reusable or recyclable.

### 11.2. Disassembly

Preparatory tasks	
1.	Depressurise the device and secure against pressure being applied again.
2.	De-energise the device and secure it against being switched back on again. Remove the mains plug. →A “click” noise indicates the opening of the solenoid valve., which makes pressure drop in the device possible.

Disassemble the drying system in the reverse order to assembly.

### 11.3. Disposal of components

Mechanical, electrical and electronic components must not be disposed of via municipal waste disposal companies or household waste. At the end of its useful life, the product must be disposed of properly e.g. by a specialist company.

- All associated parts and operating media must be disconnected on the **DRYPOINT® M eco control** and disposed of as special waste.
- Used filter element:  
**Waste code: 150203**  
 Adsorption and filter materials; cleaning wipes and protective clothing with the exception of those classified by **150202**
- Used float drain:  
 Do not dispose of as household waste! Disposal must be executed as professional and environmentally sound.

### 11.4. Preparation for return dispatch

If the **DRYPOINT® M eco control** is disassembled and prepared for dispatch, remove all residual liquids completely to avoid the condensate flowing back into the membrane. Only transport and ship the product without substances that can pose a health threat or are an environmental hazard.

## 12. Declaration of Conformity

BEKO TECHNOLOGIES GMBH  
 Im Taubental 7  
 41468 Neuss

GERMANY

Tel: +49 2131 988-0  
 www.beko-technologies.com



### EU-Konformitätserklärung

Wir erklären hiermit, dass die nachfolgend bezeichneten Produkte den Anforderungen der einschlägigen Richtlinien und technischen Normen entsprechen. Diese Erklärung bezieht sich nur auf die Produkte in dem Zustand, in dem sie von uns in Verkehr gebracht wurden. Nicht vom Hersteller angebrachte Teile und/oder nachträglich vorgenommene Eingriffe bleiben unberücksichtigt.

Produktbezeichnung:	DRYPOINT®M eco control
Modelle:	DEC1-30S DEC2-40S DEC3-60S, DEC3-80S DEC4-80S, DEC4-115S DEC5-115S DEC6-135S DEC7-165S DEC8-250S DEC9-330S
Spannungsvarianten:	95...240 VAC ±10% (50-60 Hz) / 100... 125 VDC ±10%
Max. Betriebsdruck:	10 bar (g)
Produktbeschreibung und Funktion:	Druckluft-Trocknungssystem mit Membrantrockner mit integriertem Filter/Kondensatableiter und sensorgesteuerter Drucktaupunktsteuerung zur Einstellung stabiler Trocknungsgrade.

**Niederspannungs-Richtlinie 2014/35/EU**  
 Angewandte harmonisierte Normen: EN 61010-1:2010

**EMV-Richtlinie 2014/30/EU**  
 Angewandte harmonisierte Normen: EN 61326-1:2013  
 EN 55011:2009 + A1:2010 Gruppe1, Klasse B

**ROHS II-Richtlinie 2011/65/EU**  
 Die Vorschriften der Richtlinie 2011/65/EU zur Beschränkung der Verwendung bestimmter gefährlicher Stoffe in Elektro- und Elektronikgeräten werden erfüllt.

Der Hersteller trägt die alleinige Verantwortung für die Ausstellung dieser Konformitätserklärung.

Neuss, 11.06.2018

Unterzeichnet für und im Namen von:

**BEKO TECHNOLOGIES GMBH**

  
 i.V. Christian Riedel  
 Leiter Qualitätsmanagement International

**BEKO TECHNOLOGIES GMBH**  
Im Taubental 7  
41468 Neuss

GERMANY

Phone: +49 2131 988-0  
www.beko-technologies.com



## EU Declaration of Conformity

We hereby declare that the products named below comply with the stipulations of the relevant directives and technical standards. This declaration only refers to products in the condition in which they have been placed into circulation. Parts which have not been installed by the manufacturer and/or modifications which have been implemented subsequently remain unconsidered.

Product designation:	DRYPOINT®M eco control
Type:	DEC1-30S DEC2-40S DEC3-60S; DEC3-80S DEC4-80S; DEC4-115S DEC5-115S DEC6-135S DEC7-165S DEC8-250S DEC9-330S
Supply voltage versions:	95...240 VAC ±10% (50-60 Hz) / 100...125 VDC ±10%
Maximum operating pressure:	10 bar (g)
Product description and function:	Compressed air drying system with membrane dryer with integrated filter/condensate drain and sensor controlled pressure dew point control for the setting of stable degrees of dryness.

### Low Voltage Directive 2014/35/EU

Applied harmonised standards: EN 61010-1:2010

### EMC Directive 2014/30/EU

Applied harmonised standards: EN 61326-1:2013  
EN 55011:2009 + A1:2010 group 1, class B

### RoHS II Directive 2011/65/EU

The products meet the requirements laid down in European Directive 2011/65/EU concerning the restriction of the use of certain hazardous substances in electrical and electronic devices.

The manufacturer shall have sole responsibility for issuing this declaration of conformity.

Signed for and on behalf of:

Neuss, 11/06/2018

**BEKO TECHNOLOGIES GMBH**

i.V. Christian Riedel  
Head of International Quality Management

**BEKO TECHNOLOGIES GmbH**

Im Taubental 7  
 D - 41468 Neuss  
 Tel. +49 2131 988 0  
 Fax +49 2131 988 900  
 info@beko-technologies.com

**DE****BEKO TECHNOLOGIES LTD.**

Unit 11-12 Moons Park  
 Burnt Meadow Road  
 North Moons Moat  
 Redditch, Worcs, B98 9PA  
 Tel. +44 1527 575 778  
 info@beko-technologies.co.uk

**GB****BEKO TECHNOLOGIES S.à.r.l.**

Zone Industrielle  
 1 Rue des Frères Rémy  
 F - 57200 Sarreguemines  
 Tél. +33 387 283 800  
 info@beko-technologies.fr

**FR****BEKO TECHNOLOGIES B.V.**

Veenen 12  
 NL - 4703 RB Roosendaal  
 Tel. +31 165 320 300  
 benelux@beko-technologies.com

**NL****BEKO TECHNOLOGIES  
(Shanghai) Co. Ltd.**

Rm. 606 Tomson Commercial Building  
 710 Dongfang Rd.  
 Pudong Shanghai China  
 P.C. 200122  
 Tel. +86 21 508 158 85  
 info.cn@beko-technologies.cn

**CN****BEKO TECHNOLOGIES s.r.o.**

Na Pankraci 58  
 CZ - 140 00 Praha 4  
 Tel. +420 24 14 14 717 /  
 +420 24 14 09 333  
 info@beko-technologies.cz

**CZ****BEKO Tecnológica España S.L.**

Torruella i Urpina 37-42, nave 6  
 E - 08758 Cervelló  
 Tel. +34 93 632 76 68  
 Mobil +34 610 780 639  
 info.es@beko-technologies.es

**ES****BEKO TECHNOLOGIES LIMITED**

Unit 1010 Miramar Tower  
 132 Nathan Rd.  
 Tsim Sha Tsui Kowloon Hong Kong  
 Tel. +852 5578 6681 (Hong Kong)  
 +86 147 1537 0081 (China)  
 tim.chan@beko-technologies.com

**HK****BEKO TECHNOLOGIES INDIA Pvt. Ltd.**

Plot No.43/1 CIEEP Gandhi Nagar  
 Balanagar Hyderabad  
 IN - 500 037  
 Tel. +91 40 23080275 /  
 +91 40 23081107  
 Madhusudan.Masur@bekoindia.com

**IN****BEKO TECHNOLOGIES S.r.l**

Via Peano 86/88  
 I - 10040 Leini (TO)  
 Tel. +39 011 4500 576  
 Fax +39 0114 500 578  
 info.it@beko-technologies.com

**IT****BEKO TECHNOLOGIES K.K**

KEIHIN THINK Building 8 Floor  
 1-1 Minamiwatarida-machi  
 Kawasaki-ku, Kawasaki-shi  
 JP - 210-0855  
 Tel. +81 44 328 76 01  
 info@beko-technologies.jp

**JP****BEKO TECHNOLOGIES Sp. z o.o.**

ul. Pańska 73  
 PL - 00-834 Warszawa  
 Tel. +48 22 314 75 40  
 info.pl@beko-technologies.pl

**PL****BEKO TECHNOLOGIES S.E.Asia  
(Thailand) Ltd.**

75/323 Soi Romklao, Romklao Road  
 Sansab Minburi  
 Bangkok 10510  
 Tel. +66 2-918-2477  
 info.th@beko-technologies.com

**TH****BEKO TECHNOLOGIES Co.,Ltd**

16F.-5 No.79 Sec.1  
 Xintai 5th Rd., Xizhi City  
 New Taipei City 221  
 Taiwan (R.O.C.)  
 Tel. +886 2 8698 3998  
 info.tw@beko-technologies.tw

**TW****BEKO TECHNOLOGIES CORP.**

900 Great Southwest Pkwy SW  
 US - Atlanta, GA 30336  
 Tel. +1 404 924-6900  
 Fax +1 (404) 629-6666  
 beko@bekousa.com

**US**