

Installation and operating manual

Plug-on display for METPOINT® transducer

METPOINT® UD02

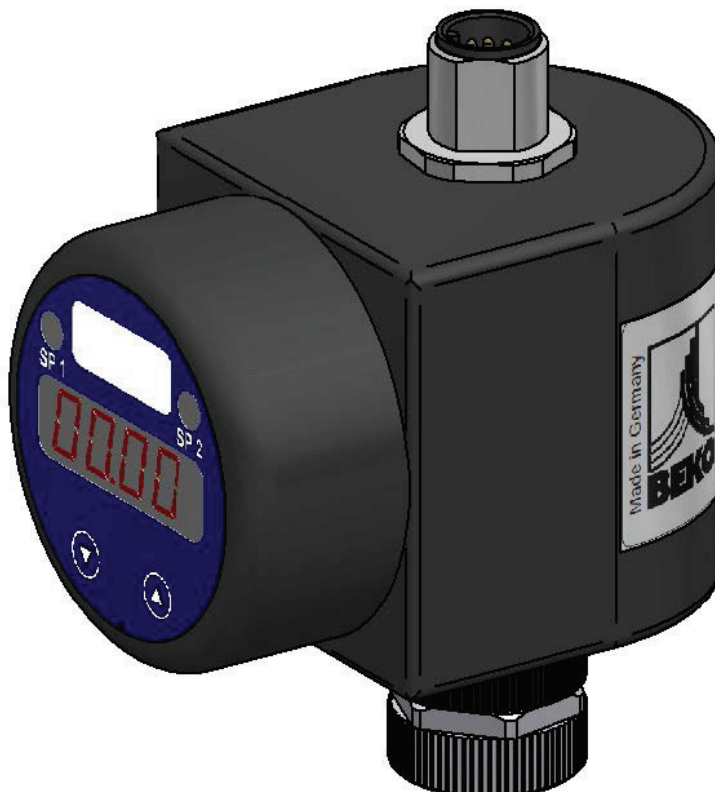

Contents

1. Safety warnings and instructions	4
1.1. Pictograms and symbols	4
1.2. Signal words according to ISO 3864 and ANSI Z.535.....	4
1.3. General safety instructions	5
2. Product information	6
2.1. Proper use	6
2.2. Type plate	6
2.3. Technical data	7
2.4. Dimensions.....	8
2.5. Scope of delivery	8
2.6. Transport and storage	9
2.7. Control and display elements	10
2.8. Menu control.....	10
2.9. Password protection.....	11
2.10. Menu layout.....	11
2.11. Unit	12
2.12. Menu list.....	12
2.12.1. Special menus.....	15
3. Installation	16
3.1. Installation	16
4. Electrical installation	17
4.1. Connection to power supply	18
4.2. Power supply for METPOINT® DPM SD21 / SD11 2-wire transducer	18
4.3. Power supply for METPOINT® PPM SP21 / SP11 / SP61 2-wire transducer.....	18
5. Commissioning	19
6. Decommissioning	19
7. Maintenance and servicing	19
7.1. Cleaning display	19
8. Troubleshooting and repair	19
9. Dismantling and disposal	19
10. Declaration of Conformity	20

1. Safety warnings and instructions

1.1. Pictograms and symbols



General instruction



Observe installation and operating instructions

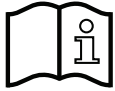

Observe installation and operating instructions
(on type plate)



General hazard symbol (danger, warning, caution)

1.2. Signal words according to ISO 3864 and ANSI Z.535

DANGER

Imminent danger

Consequences of non-compliance: serious or fatal injury

WARNING

Potential danger

Consequences of non-compliance: possible serious or fatal injury

CAUTION

Imminent danger

Consequences of non-compliance: possible injury and/or damage to property

NOTE

Additional notes, tips and hints

Consequences of non-compliance: inefficient operation, extra maintenance work.
No risk to persons.

1.3. General safety instructions

NOTE	Installation and operating manual
	<p>First make sure that the installation and operating manual actually refers to your device type. This document contains important information and instructions for the safe operation of the device. Before carrying out any work with or on the device, all specialist technical personnel ¹ must have read this manual.</p> <p>A copy of this installation and operating manual must be kept near the device where it is at all times accessible to staff.</p> <p>In addition to the instructions in this document, always comply with the statutory regulations for machine operation, accident prevention and safety. This also applies to the use of accessories and spare parts.</p>

DANGER	Insufficient qualification
	<p>Improper handling and operation of the device can result in serious or even fatal injury, and/or damage to property.</p> <ul style="list-style-type: none"> • All tasks described in this installation and operating manual must be performed by specialist technical personnel¹ who meet the following criteria: • Before carrying out any work with or on the device, all specialist technical personnel¹ must have read and understood the contents of this installation and operating manual. It is the responsibility of the owner of the device to ensure that the above requirement is complied with.

¹ Specialist technical personnel

Specialist technical personnel are persons who, due to their professional qualification and knowledge in the field of measuring, control and pneumatic technology, and their knowledge of the applicable statutory regulations, guidelines and standards are in a position to foresee potential dangers in relation to the use of the device and who are qualified to perform the tasks described in this manual. Special operating conditions (e.g. aggressive media) require additional knowledge.

DANGER	Operation of device outside limit range
	<p>If the specified limits are exceeded, there is a risk of device malfunction, potentially resulting in injury and damage to materials.</p> <ul style="list-style-type: none"> • The device must only be operated for the intended purpose and within the permissible limits specified on the type plate and in the technical data.

2. Product information

2.1. Proper use

The METPOINT® UD02 plug-on display is compatible with all 4 ... 20 mA transducers equipped with a 2-wire analogue output. It is designed for installation between the transducer and the cable box and is instantly ready for use. The METPOINT® UD02 is freely programmable using a menu system operated by two buttons. The programmed parameters are stored in EEPROM so that they are not lost in the event of a power failure. Exceedances in both directions result in a message, and the respective signals can be forwarded to 2 switching outputs. The integrated diagnostic system continuously monitors all display functions.

The device is not suitable for operation in potentially explosive atmospheres

and must only be used for the intended use. The manufacturer shall not be liable for damage caused by improper use or unauthorised modification of the device. Any such use or modification shall void all warranty.

2.2. Type plate

The type plate is attached to the device housing. It contains all relevant technical data of the METPOINT® UD02 plug-on display. Please have these details to hand when contacting the manufacturer or supplier: The operating system software version (e.g. P07) of the device is displayed for approx. 1 second on the display after switching on. Please note down the version code so to have it to hand for any queries.

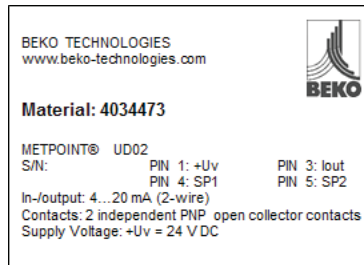

METPOINT UD02	Product description
S/N: 1234567	Serial number
PIN 1: +U_v	Voltage input (+U _v)
PIN 3: I_{OUT}	Current output (I _{OUT})
PIN 4: SP1	Switching output 1 (SP1)
PIN 5: SP2	Switching output 2 (SP2)
Input/output: 4 ... 20mA / 2-wire	Input/output signal
Contacts: 2 independent PNP open collector contacts	Contact: 2 independent PNP open collector contacts
Supply voltage: +U_v=24 VDC	Power supply

NOTE	Type plate
	Do not remove or cover the type plate and protect it against damage.

2.3. Technical data

Input and output signals	
Input and output signal	4 ... 20 mA (2 conductors) Supply from signal current loop, voltage drop ≤ 6 V $U_B = (U_{MU \min} \dots U_{MU \max}) + 6$ VDC at U_{MU} = operating voltage of connected transducer
Switching outputs	
Number, type	Max. 2 independent PNP open collector contacts
Switching power	$U_{\text{Switch}} = U_B - 2$ V; max. load 125 mA, short-circuit proof
Max. switching current	70 mA
Reproducibility	$\leq \pm 0.1$ % Full Scale Output (FSO)
Switching frequency	max. 10 Hz
Switching cycles	$> 100 \times 10^6$
Delay	0 ... 100 s
Electrical protection	
Short-circuit resistance	permanent
Polarity reversal protection	No damage, no function
Electromagnetic compatibility	Emitted interference and interference resistance according to EN 61326
Safety limits	$U_i = 28$ V, $\sum I_i = 93$ mA, $\sum P_i = 660$ mW
Display	
Type	Four-digit red 7-segment LED display, digit height 7 mm, digit width 4.85 mm
Range	-1999 ... +9999
Accuracy	0.1 % ± 1 digit
Digital attenuation	0.3 ... 30 s (programmable)
Display update frequency	0.0 ... 10 s (programmable)
Mechanical strength	
Vibration	5 g RMS (20 ... 2000 Hz)
Shock	100 g / 11 ms
Temperature range	
Ambient temperature	-25 ... 85 °C
Storage and transport temperature	-40 ... 85 °C
Materials	
Display housing	PA 6.6, polycarbonate
Miscellaneous	
Weight	approx. 100 g
Configuration memory	EEPROM, non-volatile
Protection class	IP 65

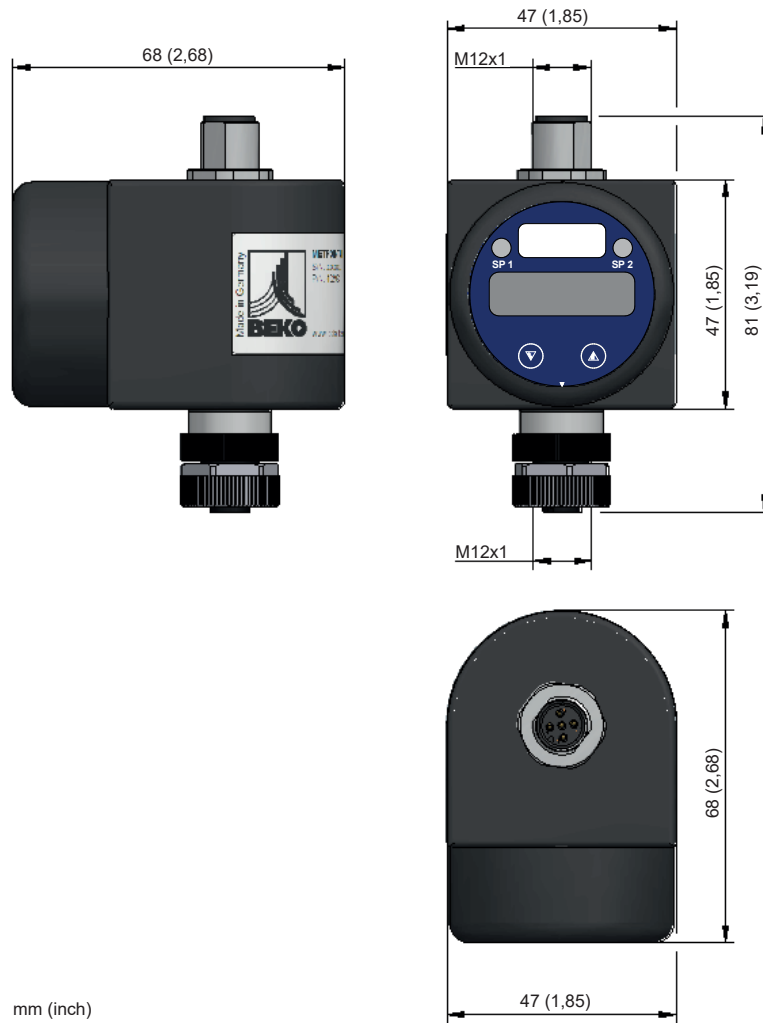

2.4. Dimensions

Dimensions in mm (inch)

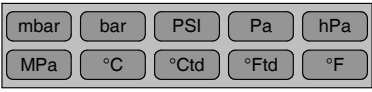

mm (inch)

2.5. Scope of delivery

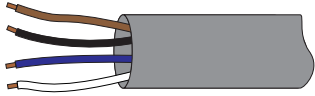
Figure	Description
	<p>Plug-on display</p>
	<p>Unit label sheet</p>
	<p>Installation and operating manual</p>
	<p>Connecting cable (5 m)</p>

2.6. Transport and storage

Despite our best efforts regarding packaging, etc., the device is susceptible to damage during transport. Upon receipt, please remove all packaging material and inspect the device for visible damage. If you detect any such damage, immediately notify the carrier company and BEKO TECHNOLOGIES GMBH or one of its agents.

CAUTION	Damage caused during transport or storage
	Incorrect transport or storage, or the use of unsuitable lifting equipment might cause damage to the device.
	<ul style="list-style-type: none">• The device must only be transported and stored by authorised and suitably trained specialist technical personnel.• If you detect any damage, do not start the device.• Always adhere to the specified transport and storage temperatures.

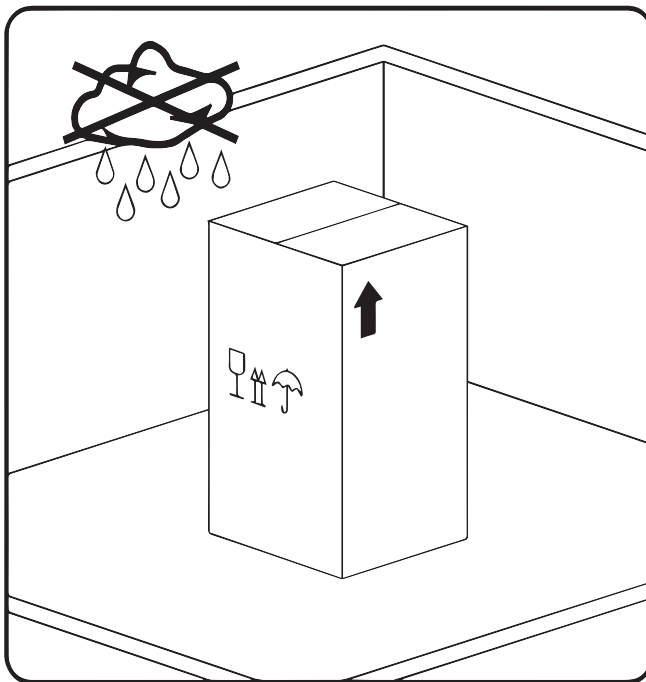

The device must be stored in the original packaging. Seal the packaging and store it in a dry and frost-free room. Ensure that the storage temperature does not exceed the limits specified on the type plate.

Even when packaged, take suitable measures to protect the device against the elements.

While in storage, secure the device so that it cannot topple over or fall, and protect it against vibration.

NOTE	Recycling of packaging material
	<ul style="list-style-type: none">• The packaging material is recyclable. Dispose of the packaging material according to the applicable statutory regulations.

2.7. Control and display elements

The measured value is displayed on a 4-digit, 7-segment display panel that is also used to configure the device.

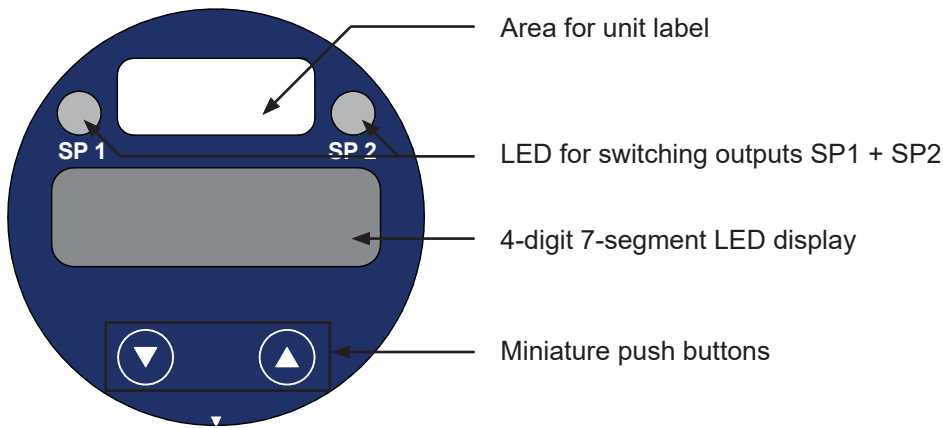

2.8. Menu control

The device menu is operated through the miniature push buttons. All settings are stored in EEPROM and thus remain available even after a power failure.



- Menu >>▲<< UP
- Increase displayed value



- Menu >>▼<< DOWN
- Reduce displayed value

The stepping speed for the adjustment of the displayed value can be increased by pressing and holding the respective push button for minimum 5 seconds.

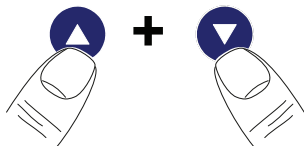

- Confirm set value
- Change between configuration and display mode
- Open selected value

After adjusting the parameter value, confirm the entry and exit the respective menu. The new parameter value is now applied.

2.9. Password protection

The device menu is password-protected.

Factory-set password:
 Enable/disable password protection:
 Change password:
 Reset password:

0005
 see >>Menu 1<<
 see >>Special menu 4<<
 see >>Special menu 3<<

2.10. Menu layout

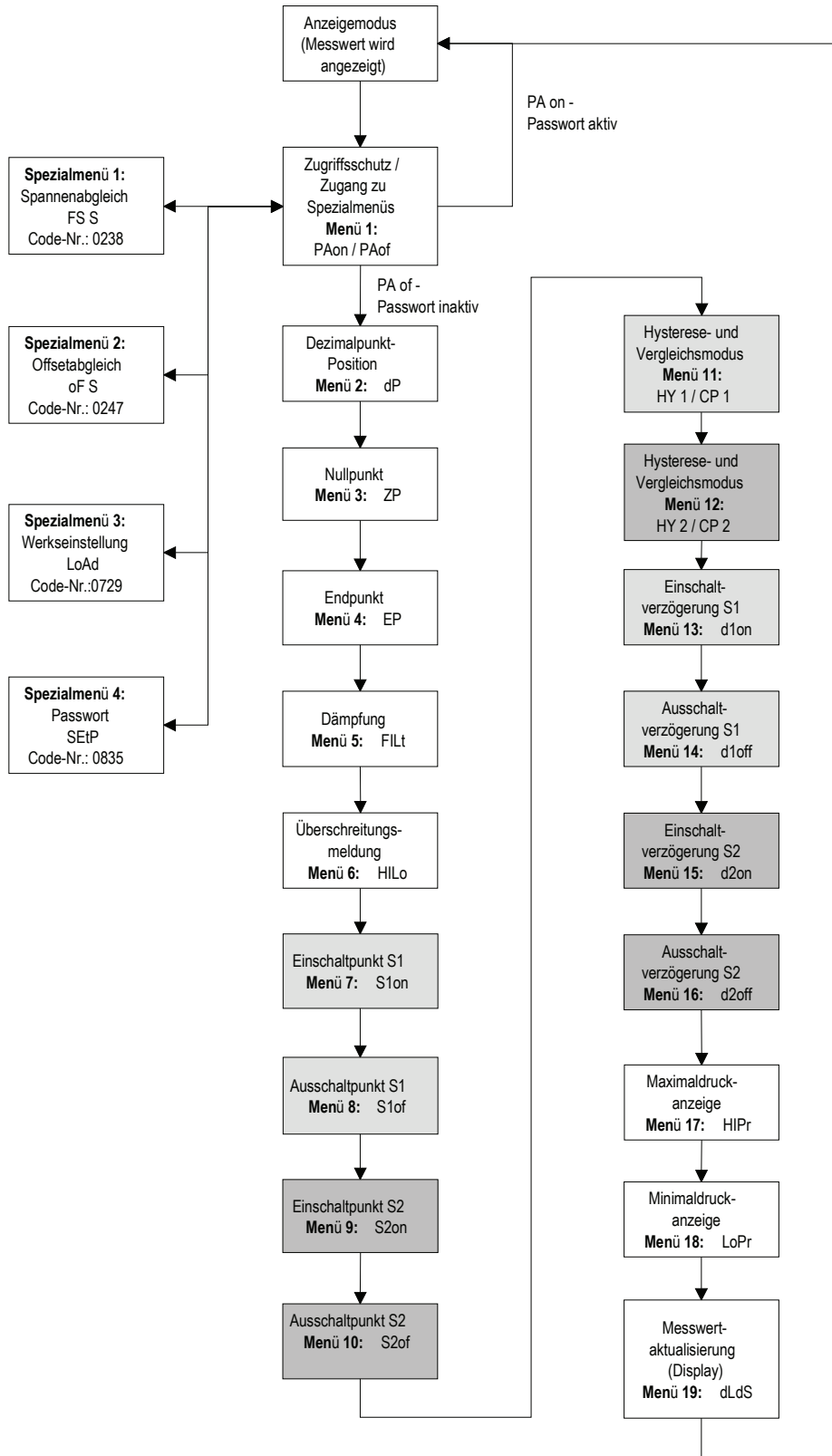

2.11. Unit

The unit of the displayed value is factory-set and indicated on the area where the unit label can be placed.

2.12. Menu list

PAon

Menu 1 – Password protection

If password protection is enabled, "PAon" is shown on the display.

To disable password protection: Simultaneously press >>▲<< and >>▼<< to confirm menu option "PAon". Then press >>▲<< or >>▼<< to enter the password and confirm by pressing both buttons. Password protection is now disabled and "PAof" is shown on the display.

PAof

If password protection is disabled, "PAof" is shown on the display.

To enable password protection: Simultaneously press >>▲<< and >>▼<< to confirm menu option "PAof". Then press >>▲<< or >>▼<< to enter the password and confirm by pressing both buttons. Password protection is now enabled and "PAon" is shown on the display.

The factory-set password is "0005".

The password can be changed in special menu 4.

dP

Menu 2 – Setting decimal point position

Simultaneously press >>▲<< and >>▼<< to confirm menu option "dP". Then press >>▲<< or >>▼<< to set the decimal point to the correct position and confirm by pressing both buttons.

ZP

Menu 3 – Setting zero point

Simultaneously press >>▲<< and >>▼<< to confirm menu option "ZP". Then press >>▲<< or >>▼<< to set the zero point and confirm by pressing both buttons.

The set value is displayed when the electric output signal of the transducer is 4 mA (zero point).

EP

Menu 4 – Setting end point

Simultaneously press >>▲<< and >>▼<< to confirm menu option "EP". Then press >>▲<< or >>▼<< to set the end point and confirm by pressing both buttons.

The set value is displayed when the electric output signal of the transducer is 20 mA (end point).

FILt

Menu 5 – Setting attenuation (filter)

Simultaneously press >>▲<< and >>▼<< to confirm menu option "FILt". Then press >>▲<< or >>▼<< to set the time constant of the analogue low-pass filter and confirm by pressing both buttons.

Value range: 0.3 ... 30 s

This parameter ensures constant display, even if the measured values fluctuate greatly.

HILo

Menu 6 – Enabling/disabling range exceedance alarm

Enable/disable alarm: Simultaneously press >>▲<< and >>▼<< to confirm menu option "HILo". Then press >>▲<< or >>▼<< to set the exceedance alarm function to "on" or "off" and confirm by pressing both buttons.

S1on

Menu 7 – Setting switch-on point for switching output 1

Simultaneously press >>▲<< and >>▼<< to confirm menu option "S1on". Then press >>▲<< or >>▼<< to set the desired value and confirm by pressing both buttons.

S1of

Menu 8 – Setting switch-off point for switching output 1

Simultaneously press >>▲<< and >>▼<< to confirm menu option "S1of". Then press >>▲<< or >>▼<< to set the desired value and confirm by pressing both buttons.

S2on

Menu 9 – Setting switch-on point for switching output 2

Simultaneously press >>▲<< and >>▼<< to confirm menu option "S2on". Then press >>▲<< or >>▼<< to set the desired value and confirm by pressing both buttons.

S2of

Menu 10 – Setting switch-off point for switching output 2

Simultaneously press >>▲<< and >>▼<< to confirm menu option "S2of". Then press >>▲<< or >>▼<< to set the desired value and confirm by pressing both buttons.

HY 1

Menu 11 – Setting hysteresis and reference module at switching output 1

Simultaneously press >>▲<< and >>▼<< to confirm menu option "HY 1" or "CP 1" respectively. Then press >>▲<< or >>▼<< to set the desired mode and confirm by pressing both buttons.

CP 1

The figures below show the hysteresis and reference modes and their inversions. To invert the mode, exchange the switch-on and switch-off points.

Reference mode

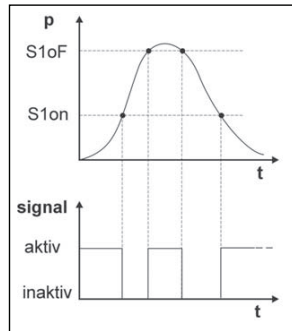

Inverted reference mode

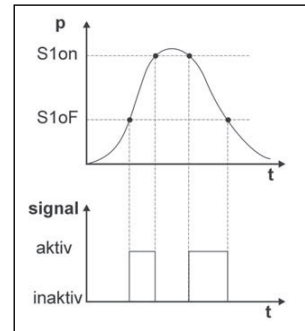

Hysteresis mode

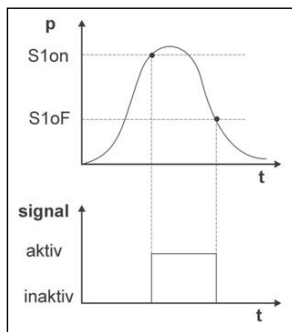

Inverted hysteresis mode

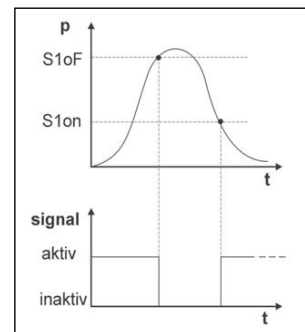

HY 2

Menu 12 – Setting hysteresis and reference module at switching output 2

Simultaneously press >>▲<< and >>▼<< to confirm menu option "HY 2" or "CP 2" respectively. Then press >>▲<< or >>▼<< to set the desired mode and confirm by pressing both buttons.

CP 2

Menu 13 – Setting switch-on delay for switching output 1

Simultaneously press >>▲<< and >>▼<< to confirm menu option "d1on". Then press >>▲<< or >>▼<< to set the desired time and confirm by pressing both buttons.

Menu 14 – Setting switch-off delay for switching output 1

Simultaneously press >>▲<< and >>▼<< to confirm menu option "d1of". Then press >>▲<< or >>▼<< to set the desired time and confirm by pressing both buttons.

Menu 15 – Setting switch-on delay for switching output 2

Simultaneously press >>▲<< and >>▼<< to confirm menu option "d2on". Then press >>▲<< or >>▼<< to set the desired time and confirm by pressing both buttons.

Menu 16 – Setting switch-off delay for switching output 2

Simultaneously press >>▲<< and >>▼<< to confirm menu option "d2of". Then press >>▲<< or >>▼<< to set the desired time and confirm by pressing both buttons.

Menu 17 – Maximum value display

Simultaneously press >>▲<< and >>▼<< to confirm menu option "H1Pr". The highest value measuring during the current measuring series is displayed.

Reset maximum value: Simultaneously press >>▲<< and >>▼<< within 1 second after confirmation of the menu option.

The maximum value is automatically reset when the device is de-energized.

Menu 18 – Minimum value display

Simultaneously press >>▲<< and >>▼<< to confirm menu option "LoPr". The lowest value measuring during the current measuring series is displayed.

Reset minimum value: Simultaneously press >>▲<< and >>▼<< within 1 second after confirmation of the menu option.

The minimum value is automatically reset when the device is de-energized.

Menu 19 – Measured value update (display)

Simultaneously press >>▲<< and >>▼<< to confirm menu option "dLdS". Press >>▲<< and/or >>▼<< to set the time interval for the update of the display and confirm by simultaneously pressing the two buttons.

Value range: 0 ... 10 s

2.12.1. Special menus

The special menus can be accessed through menu 1.
All settings described below must be made in menu 1.



Special menu 1 – Display correction for deviating span signal (span correction). To correct the display in the event of a deviating span, press >>▲<< and >>▼<< to set the display value to "0238". Confirm by pressing the two buttons simultaneously. "FS S" is shown on the display. Pressurize the device with a reference pressure that corresponds to the upper measuring range end point value. Press the two buttons again to save the current output signal from the transmitter as the span signal. From now on, the display shows the set end point value, although the sensor signal is offset from the span signal.

Please note that the output signal is not affected by this configuration.



Special menu 2 – Zeroing display in the event of a deviating offset (offset correction)
To zero the display in the event of a deviating offset, press >>▲<< and >>▼<< to set the display value to "0247". Confirm by pressing the two buttons simultaneously. "of S" is shown on the display. If the offset deviates from the ambient pressure, pressurise the device with a reference pressure that corresponds to the lower measuring range end point value. Press the two buttons again to save the current output signal from the transmitter as the offset signal. From now on, the display shows the set end point value (zero point), although the sensor signal is offset from the span signal. Please note that the output signal is not affected by this configuration. This offset correction also results in an offset of the span value (full scale).



Special menu 3 – Resetting to factory settings (loading defaults)
To load the default settings, press >>▲<< and >>▼<< to set the display to value "0729". Confirm by pressing the two buttons simultaneously. Confirm again by pressing the two buttons simultaneously.

When the default values (factory settings) are loaded, all previously made adjustments and the password are reset.



Special menu 4 – Changing password
To change the password, press >>▲<< and >>▼<< to set the display to value "0835". Confirm by pressing the two buttons simultaneously. Then press >>▲<< or >>▼<< to enter the new password and confirm by pressing both buttons.

Value range: 0 ... 9999

NOTE	The values below are already assigned and cannot be used as passwords:
	0238, 0247, 0729 and 0835

3. Installation

NOTE	Risk of damage to device
	<ul style="list-style-type: none">• Before installing and connecting the device, ensure that the entire system is de-energized.• Never exceed the rotation and tightening limits of the components.

3.1. Installation

1. Screw the plug-on display (2) to the compatible transducer (3).
2. Screw the cable box (1) to the plug-on display (2).

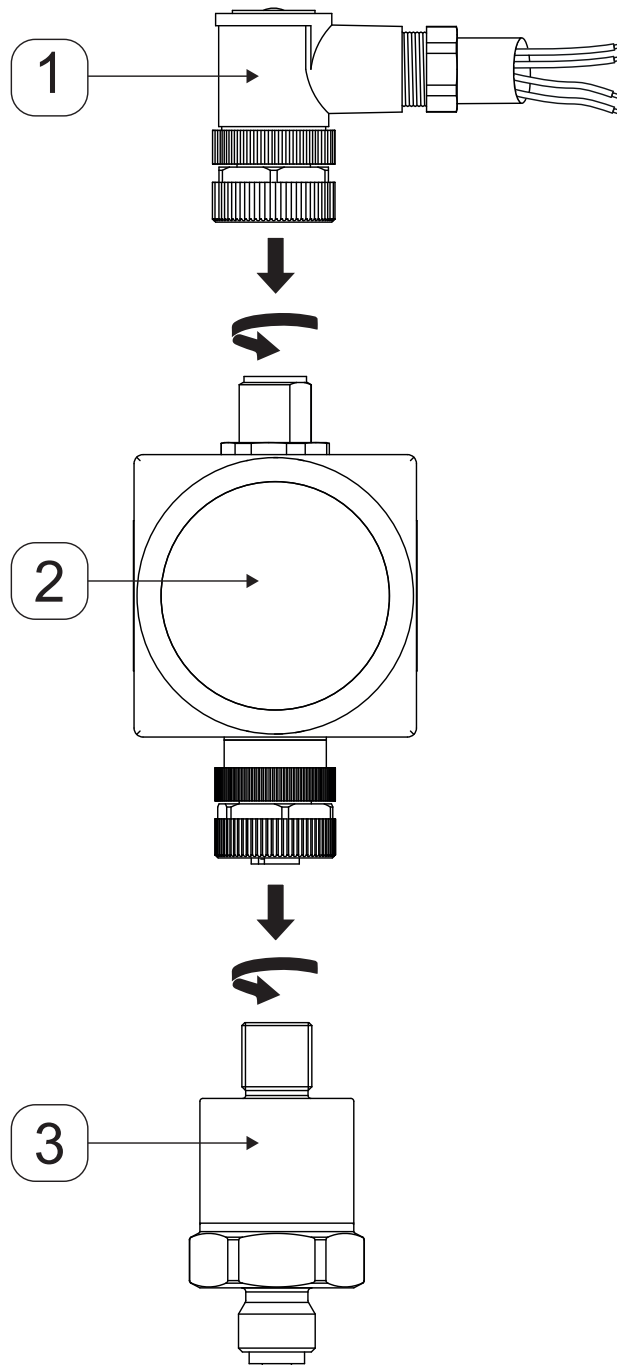

4. Electrical installation

For the electrical installation, refer to the table and wiring diagrams below.

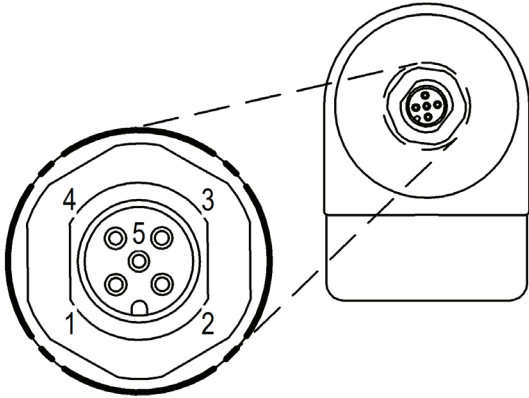
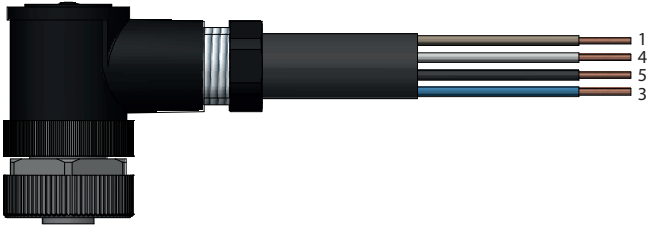
Electrical connections	
Picture	Pin assignment
	<p>1 – power supply (+) 24V DC</p> <p>2 – not assigned</p> <p>3 – power supply (-) 0V or GND</p> <p>4 – switching output 1 (SP1)</p> <p>5 – switching output 2 (SP2)</p>
	<p>1 – power supply (+) 24V DC Wire colour: BROWN</p> <p>3 – power supply (-) 0V or GND Wire colour: BLUE</p> <p>4 – switching output 1 Wire colour: WHITE</p> <p>5 – switching output 2 Wire colour: BLACK</p>

4.1. Connection to power supply

The voltage drop caused by the electronics in the device is approx. 6 VDC. This must be taken into account when dimensioning the power supply. The limit values are calculated as follows:

Minimum operating voltage:
$$U_{B \min} = U_{MU \min} + 6 \text{ V}$$

Maximum operating voltage:
$$U_{B \max} = U_{MU \max} + 6 \text{ V}$$

Key:

$U_{\min MU}$ = minimum operating voltage of installed 2-wire transducer

$U_{\max MU}$ = maximum operating voltage of installed 2-wire transducer

4.2. Power supply for METPOINT® DPM SD21 / SD11 2-wire transducer

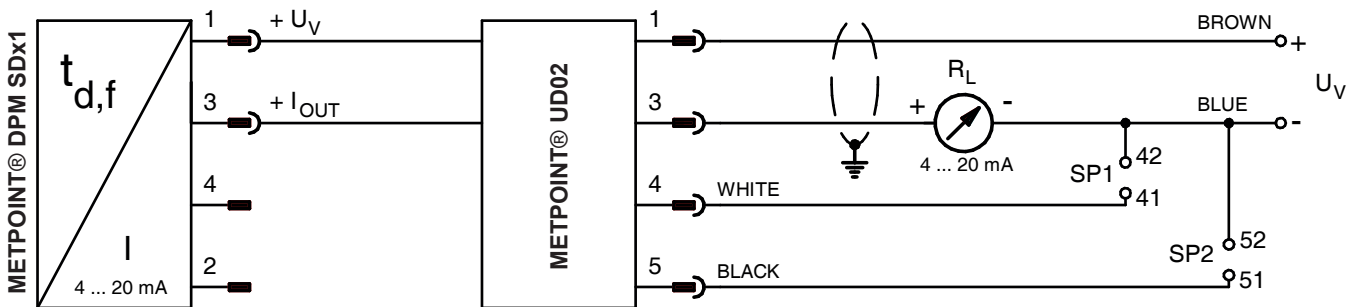

4.3. Power supply for METPOINT® PPM SP21 / SP11 / SP61 2-wire transducer

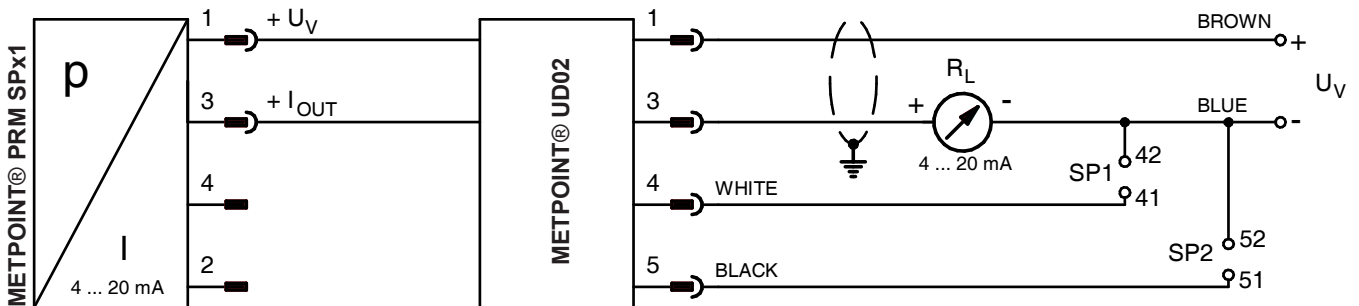

5. Commissioning

After the METPOINT® UD02 plug-on display has been correctly installed and connected, it is ready for operation.

6. Decommissioning

To decommission the plug-on display, disconnect it from the power supply, remove it from the transducer by performing the installation steps in reverse order and dispose of it according to the disposal instructions in chapter "9. Dismantling and disposal", page 19.

7. Maintenance and servicing

The plug-on display does not need any maintenance. From time to time, it might need to be cleaned as described below.

7.1. Cleaning display

To clean the METPOINT® UD02 plug-on display, switch it off and use a damp (but not wet) cotton cloth or disposable tissue and a mild conventional detergent.

Spray a little detergent onto the clean cotton cloth or tissue and carefully wipe the component. Dry it with a clean cloth. Observe all hygiene instructions applicable on the site.

NOTE	Damage caused by improper cleaning
	<p>Cleaning with a wet cloth, pointed implement or aggressive detergent can cause damage to the plug-on display and its electronic components.</p> <ul style="list-style-type: none"> • Never clean the device with a wet cloth. • Do not use aggressive detergents. • Do not clean the device with hard or pointed implements. • Before cleaning the device, switch it off.

8. Troubleshooting and repair

In the event of a malfunction of the device, return it to the manufacturer for repair. Clean the device carefully and pack it so that it is protected against impact. Return the device to the manufacturer, enclosing a return declaration with a detailed description of the fault/malfunction. If your device has come into contact with a hazardous substance, also enclose a declaration of decontamination. The relevant templates can be downloaded from our homepage at www.beko-technologies.de. If your device arrives at our service workshop without a declaration of decontamination, and should our personnel be concerned about any media with which it might have come into contact, we will contact you. A repair will only be performed after we have received the relevant declaration of decontamination. If the device has been exposed to a hazardous substance, take all necessary safety precautions when cleaning it!

9. Dismantling and disposal

Dispose of the device according to the European Directive 2012/19/EU (waste electrical and electronic equipment (WEEE)). Never dispose of it with normal household waste!

If the device has been in contact with a hazardous substance, it might need to be disposed of through a specialist hazardous waste disposal contractor!

10. Declaration of Conformity

BEKO TECHNOLOGIES GMBH
 Im Taubental 7
 D-41468 Neuss, GERMANY
 Tel: +49 2131 988-0
 www.beko-technologies.com



EU-Konformitätserklärung

Wir erklären hiermit, dass die nachfolgend bezeichneten Produkte den Anforderungen der einschlägigen Richtlinien und technischen Normen entsprechen. Diese Erklärung bezieht sich nur auf die Produkte in dem Zustand, in dem sie von uns in Verkehr gebracht wurden. Nicht vom Hersteller angebrachte Teile und/oder nachträglich vorgenommene Eingriffe bleiben unberücksichtigt.

Produktbezeichnung:	METPOINT® UD02
Typ:	4034473
Anzeigebereich:	-1999 ... +9999
Versorgungsspannung:	24 VDC
Max. Versorgungsspannung:	30 VDC
Min. / Max. Umgebungstemperatur:	-25°C / +85°C
IP-Schutzart	IP65
Zeichnungs-Nr.:	UD02_ALG_R02
Datenblatt:	DB_UD02-0616-FP-A
Produktbeschreibung und Funktion:	Aufsteckanzeige für METPOINT Messumformer

EMV-Richtlinie 2014/30/EU

Angewandte harmonisierte Normen: EN 61326-1:2013

ROHS II-Richtlinie 2011/65/EU

Die Vorschriften der Richtlinie 2011/65/EU zur Beschränkung der Verwendung bestimmter gefährlicher Stoffe in Elektro- und Elektronikgeräten werden erfüllt.

Die Produkte sind mit dem abgebildeten Zeichen gekennzeichnet:



Die alleinige Verantwortung für die Ausstellung dieser Konformitätserklärung trägt der Hersteller.

Neuss, 13.06.2016

Unterzeichnet für und im Namen von:

BEKO TECHNOLOGIES GMBH

i.V. Christian Riedel

Leiter Qualitätsmanagement International

BEKO TECHNOLOGIES GMBH
 Im Taubental 7
 41468 Neuss, GERMANY
 Phone: +49 2131 988-0
 www.beko-technologies.com



EU Declaration of Conformity

We hereby declare that the products indicated hereafter comply with the stipulations of the relevant directives and technical standards. This declaration only refers to products in the condition in which they have been placed into circulation. Parts which have not been installed by the manufacturer and/or modifications which have been implemented subsequently remain unconsidered.

Product designation:	METPOINT® UD02
Type:	4034473
Display range:	-1999 / +9999
Supply voltage:	24 VAC
Max. supply voltage:	30 VAC
Min./max. ambient temperature:	-25°C / +85°C
Degree of protection	IP65
Drawing no.:	UD02_ALG_R02
Data sheet:	DB_UD02-0616-FP-A
Product description and function:	Plug-on display for METPOINT transducers

EMC Directive 2014/30/EU

Applied harmonized standards: EN 61326-1:2013

RoHS II Directive 2011/65/EU

The products meet the requirements laid down in European Directive 2011/65/EU concerning the restriction of the use of certain hazardous substances in electrical and electronic devices.

The products bear the CE Mark:



This Declaration of Conformity has been issued by the manufacturer.

Neuss, 17/06/2016

Signed:
BEKO TECHNOLOGIES GMBH

ppa Christian Riedel
 Head of International Quality Management

CE_UD02-856-0616-FP-A

Headquarter**Deutschland / Germany**

BEKO TECHNOLOGIES GMBH
Im Taubental 7
D - 41468 Neuss
Tel. +49 2131 988 0
beko@beko-technologies.de

United Kingdom

BEKO TECHNOLOGIES LTD.
Unit 11-12 Moons Park
Burnt Meadow Road
North Moons Moat
Redditch, Worcs, B98 9PA
Tel. +44 1527 575 778
info@beko-technologies.co.uk

France

BEKO TECHNOLOGIES S.à.r.l.
Zone Industrielle
1 Rue des Frères Rémy
F - 57200 Sarreguemines
Tél. +33 387 283 800
info@beko-technologies.fr

Benelux

BEKO TECHNOLOGIES B.V.
Veenen 12
NL - 4703 RB Roosendaal
Tel. +31 165 320 300
benelux@beko-technologies.com

中华人民共和国 / China

BEKO TECHNOLOGIES (Shanghai)
Co. Ltd.
Rm. 606 Tomson Commercial Building
710 Dongfang Rd.
Pudong Shanghai China
P.C. 200122
Tel. +86 21 508 158 85
info.cn@beko-technologies.cn

Česká Republika / Czech Republic

BEKO TECHNOLOGIES s.r.o.
Na Pankraci 58
CZ - 140 00 Praha 4
Tel. +420 24 14 14 717
info.cz@beko-technologies.cz

España / Spain

BEKO Tecnológica España S.L.
Torruella i Urpina 37-42, nave 6
E - 08758 Cervelló
Tel. +34 93 632 76 68
info.es@beko-technologies.es

中華人民共和國香港特別行政區 /**Hong Kong SAR of China**

BEKO TECHNOLOGIES LIMITED
Unit 1010 Miramar Tower
132 Nathan Rd.
Tsim Sha Tsui Kowloon Hong Kong
Tel. +852 5578 6681 (Hong Kong)
Tel. +86 147 1537 0081 (China)
tim.chan@beko-technologies.com

India

BEKO COMPRESSED AIR
TECHNOLOGIES Pvt. Ltd.
Plot No.43/1 CIEEP Gandhi Nagar
Balanagar Hyderabad
IN - 500 037
Tel. +91 40 23080275
madhusudan.masur@bekoindia.com

Italia / Italy

BEKO TECHNOLOGIES S.r.l
Via Peano 86/88
I - 10040 Leini (TO)
Tel. +39 011 4500 576
info.it@beko-technologies.com

日本 / Japan

BEKO TECHNOLOGIES K.K
KEIHIN THINK Building 8 Floor
1-1 Minamiwatarida-machi
Kawasaki-ku, Kawasaki-shi
JP - 210-0855
Tel. +81 44 328 76 01
info@beko-technologies.jp

Polska / Poland

BEKO TECHNOLOGIES Sp. z o.o.
Ul. Pańska 73
PL - 00-834 Warszawa
Tel. +48 22 314 75 40
info.pl@beko-technologies.pl

South East Asia

BEKO TECHNOLOGIES S.E.Asia
(Thailand) Ltd.
75/323 Soi Romklao, Romklao Road
Sansab Minburi
Bangkok 10510
Tel. +66 2-918-2477
info.th@beko-technologies.com

臺灣 / Taiwan

BEKO TECHNOLOGIES Co.,Ltd
16F.-5 No.79 Sec.1
Xintai 5th Rd. Xizhi Dist.
New Taipei City 221
Taiwan (R.O.C.)
Tel. +886 2 8698 3998
info.tw@beko-technologies.tw

USA

BEKO TECHNOLOGIES CORP.
900 Great SW Parkway
US - Atlanta, GA 30336
Tel. +1 404 924-6900
beko@bekousa.com