

Installation and operation manual

CLEARPOINT® water separator

> S040
> S050

> S075
> M010

> M015
> M020
> M022

> M025
> M030

■ Table of contents

1. General	4
1.1 Contact	4
1.2 Information regarding installation and operation manual	4
1.3 Other applicable documents	4
1.4 Explanation of the symbols and pictograms utilised	5
1.4.1 In the documentation	5
1.4.2 On the device	6
1.5 Intended use	7
1.6 Reasonably foreseeable inappropriate use	8
1.7 Legal warranty and liability for property defects	8
1.8 Target group and personnel	9
1.9 Responsibility of the operating company	9
2. Safety-related information	10
2.1 General instructions	10
2.2 Safety instructions	11
3. Transport and storage	12
4. Product information	13
4.1 Product description	13
4.2 Product overview	13
4.3 Product identification	14
4.4 Function description	16
4.4.1 Water separation	16
4.4.2 Condensate discharge through float drain	17
4.4.3 Condensate discharge through BEKOMAT	18
4.5 Scope of delivery	18
4.6 Type plate	19
4.7 Stamp on water separator insert	20
5. Technical data	21
5.1 Separator performance data	21
5.2 Materials	23
6. Dimensions	24
7. Assembly	26
7.1 Warning notices	26
7.2 Assembly work	27
8. Commissioning	29
8.1 Commissioning tasks	29
9. Maintenance and servicing	30
9.1 Maintenance schedule	30
9.2 Cleaning	30
9.2.1 Warning notices	30
9.2.2 Cleaning work	31
9.3 Visual inspection	31
9.4 Replace the float drain	32
9.5 Replacing the water separator insert	36
9.6 Leakage test	39
10. Decommissioning	40

11. Disassembly	41
11.1 Warning notices	41
11.2 Disassembly work.....	42
12. Disposal.....	44
12.1 Warning notices	44
12.2 Disposal work	44
13. Spare parts and accessories.....	45
13.1 Spare parts	45
13.2 Accessories attachment components top	45
13.3 Accessories attachment components bottom.....	46
14. Fault and trouble shooting / FAQ	47
15. Product approvals and registration marks	48

1. General

1.1 Contact

Manufacturer	Customer service and tools
BEKO TECHNOLOGIES GmbH Im Taubental 7 D-41468 Neuss Tel. + 49 2131 988 - 1000 info@beko-technologies.com www.beko-technologies.com	BEKO TECHNOLOGIES GmbH Im Taubental 7 D-41468 Neuss Tel. + 49 2131 988 - 1000 service-eu@beko-technologies.com www.beko-technologies.com

1.2 Information regarding installation and operation manual

INFORMATION	Copyright protection
	The contents of the installation and operation manual in the form of text, figures, illustrations, photographs, technical drawings, diagrams and other representations are protected by the copyright of the manufacturer. This applies especially to duplication, reproduction, microfilming and storage as well as processing in electronic systems.

Publication date	Revision status	Reason for amendment	Scope of amendment
31/10/2018	00_01	Changes to standards and regulations	Completely new version

The installation and operation manual, hereinafter referred to as the manual, must always be stored close to the product and be in a permanently legible condition.

The manual must be handed over along with the product if it is sold or passed on.

NOTE	Follow the instructions given in the manual!
	This manual contains all the basic information required for safe operation of the product and must therefore be read before any actions are performed. Otherwise personal and material hazards as well as malfunction and device failure can occur.

1.3 Other applicable documents











This manual contains all the necessary steps for installation and operation of the CLEARPOINT® water separator. More detailed information about the installation and operation of the accessories is contained in the following installation and operation manual:

- BEKOMAT® 20
- BEKOMAT® 20 Vario



1.4 Explanation of the symbols and pictograms utilised

The symbols and pictograms utilised below indicate safety-relevant and important information which must be adhered to when handling the operating material and to ensure safe and optimum operation.

1.4.1 In the documentation

Symbol/Pictogram	Description/Explanation
	General hazard symbol (danger, warning, caution)
	Pressurised system
	Note the installation and operating manual
	General instructions
	Wear respiratory protection FFP 3
	Wear safety footwear
	Wear protective gloves (fluid-resistant)
	Wear hearing protection
	Wear safety goggles with side shields
	General information

1.4.2 On the device

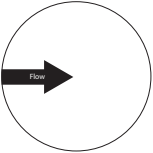
Symbol/Pictogram	Description/Explanation
	<p>General hazard symbol (danger, warning, caution) (This symbol can be found on the type plate and on the maintenance label)</p>
	<p>Note the installation and operating manual (This symbol is only located on the type plate)</p>
	<p>Maintenance label This adhesive label shows in a stylised way that the installation and operation manual must be read before maintenance work is carried out and that the product must be depressurised before maintenance work.</p>
	<p>Stamp on water separator insert (This stamp is located on the bottom of the water separator insert and provides information about the direction of flow.)</p>

1.5 Intended use

CLEARPOINT® water separator and accessories

The CLEARPOINT® water separator, also referred to as separator below, is used for separating drops of liquid and solid particles in compressed gas systems.

Any use of this system other than the use described in this manual is hereby deemed to be non-intended and can cause a hazard for the safety of users and the environment.

- Only use separators and accessories within the operating parameters given in the technical data and the agreed delivery conditions.
- Only use separators and accessories within pipework designed for the technical data with appropriate connections, pipe diameters and assembly clearance.
- Only use separators and accessories for the treatment of compressed gases of fluid group 2 according to Pressure Equipment Directive 2014/68/EU which are free of aggressive and corrosive components.
- Only use separators and accessories in non-explosive hazardous areas.
- Only use separators and accessories away from direct solar radiation and heat sources as well as areas subject to frost.
- Only combine the separators and accessories with the products named and recommended by **BEKO TECHNOLOGIES GMBH** in the manual.

Before using the separators, the operating company must make sure that all conditions and prerequisites for intended use are given.

The separator is exclusively designed for stationary use in a commercial or industrial area. All the assembly, installation, operation, disassembly and disposal work described may only be performed by qualified skilled personnel.

1.6 Reasonably foreseeable inappropriate use

Reasonably foreseeable inappropriate use is deemed to have occurred if the separators or any accessories are used in any other way than that described in the chapter "Intended use". Reasonably foreseeable inappropriate use includes the use of the product in a manner not intended by the manufacturer or supplier but which may result from foreseeable human behaviour.

Reasonably foreseeable inappropriate use includes:

- Executing of modifications of all kinds, in particular design and process engineering interventions, as these can lead to personal injury and material damage as well as malfunction and device failure.
- The overriding, bridging or non-application of existing or recommended safety devices.
- The use for treatment of compressed gases which are not included in fluid group 2 in accordance with PED 2014/68/EU or contain aggressive components. In cases of doubt a gas/condensate analysis must be carried out.

This list is not exhaustive as not all possible inappropriate use can be foreseen in advance. If the operating company is aware of any inappropriate use of the separator or accessories which are not listed here, the manufacturer must be informed immediately.

1.7 Legal warranty and liability for property defects

The operating company and user must take into account the intended use. The operating company and user will be completely liable for every not described action and utilisation which exceeds the stated intended use.

All liability or warranty claims will be invalidated insofar as the separator is not operated according to the intended use or is operated outside the specifications given in the technical data.

This includes:

- inappropriate technical installation, commissioning, servicing, maintenance or operation
- the use of defective components
- non-compliance with the safety-relevant information, procedure and instruction contained in this manual
- the performance of any kind of modification, in particular constructive and process technology interventions on the product
- the use of third-party spare parts or accessories, which have not been approved by the manufacturer, during maintenance and repair work
- Non-compliance with servicing, maintenance and inspection intervals

1.8 Target group and personnel

This manual addresses the skilled technical personnel listed below who are involved with work on the separator or the accessories.

INFORMATION	Personnel requirements
	<p>The personnel may not execute any actions on the separator or the accessories when they are under the influence of drugs, medications, alcohol or other substances that may impair their consciousness.</p>

Skilled personnel- Transport and storage

Skilled personnel - Transport and storage are people who, due to their training, professional experience and qualifications, have all the necessary skills to safely execute all actions in connection with the transport and storage of the operating material, to instruct, to recognise possible dangerous situations independently and to execute measures to avoid danger.

Skills include experience with hoists, forklifts and lifting equipment and knowledge of local laws, standards and guidelines relating to transport and storage.

Qualified personnel - compressed gas technology

Skilled personnel - compressed gas technology are people who, due to their training, professional experience and qualification, possess all the necessary capabilities to safely execute actions, and instruct all actions related to compressed gases and pressurised systems, to independently foresee potential hazardous situations and implement appropriate measures to avert any danger.

The capabilities include, in particular, experience in handling measurement and control technology as well as knowledge of the regionally applicable laws, standards and regulations for compressed gas technology.

1.9 Responsibility of the operating company

The responsible operating company must ensure the following to prevent accidents, faults and adverse effects on the environment:

- Before all actions, check to ensure that the manual available does in fact belong to the product.
- Always use, maintain and service the product properly.
- All applicable statutory requirements, safety regulations and accident prevention regulations have been adhered to.
- All regulations and operation manual for safe working and information regarding behaviour in the event of accidents and fires at the operating location are accessible to personnel at all times.
- The product is used with recommended and fully operable safety devices that are not overridden.
- Always have assembly, installation and maintenance work carried out by qualified skilled personnel only.
- Personnel have the recommended personal protective equipment at their disposal and it is used.
- Appropriate technical safety measures have been implemented to ensure that the permissible operating parameters are not exceeded or undershot.

2. Safety-related information

2.1 General instructions

Safety instructions warn against residual risks when handling the product. Warning notices in the instructional text precede the procedure that poses a hazard to personnel or the environment.

These safety and warning notices must be strictly observed in order to prevent accidents, personal injury, damage to property and impairments during operation.

Structure of the safety instructions

The content of the safety instructions is based on the **SAFE principle**:

- S - Safety symbol and signal word
- A - Type and source of danger
- F - Possible consequences of disregarding the danger in the order of its severity
- E - Measures to prevent danger

Structural design of the safety instructions:

SIGNAL WORD	Type and source of danger!
 Safety symbol	Possible consequences if the danger is ignored
	<ul style="list-style-type: none"> • Measure to prevent the danger





Signal words according to ISO 3864 and ANSI Z.535.6

DANGER	Imminent hazard Consequences of non-compliance: Death or serious personal injury
WARNING	Imminent hazard Consequences of non-compliance: Death or serious personal injury are possible
CAUTION	Potential danger Consequences of non-compliance: injury and/or damage to property
NOTE	Additional notes, information, tips Consequences of non-compliance: Disadvantages during operation, actions and maintenance. No danger to people or regarding the safe operation.

2.2 Safety instructions

In order to prevent accidents, personal injury and damage to the device as well as impairments during operation, it is essential to adhere to the specified safety and warning notices.

The personal protective equipment specified in the safety instructions must be selected and made available by the operating company depending on the system parameters and properties.

DANGER	Operation of plant outside the permissible limit range!
	Operation of the product outside the permissible limits and operating parameters, unauthorised intervention and modifications may result in death or serious injury.
	<ul style="list-style-type: none"> • For safe operation of the product, always adhere to the limit values, operating parameters and maintenance intervals as well as the set-up and ambient parameters specified on the type plate and in the manual. • Inspect whether the operating parameters have been amended or restricted by the use of accessories. • Only use the product for its intended use.
DANGER	Pressurised system!
	Death or serious personal injury can result through contact with fast or suddenly escaping compressed air or through bursting system parts
	<ul style="list-style-type: none"> • All work on the system must be carried out in the depressurised state and with the system secured against unintentional pressure build-up. • Set up a safety zone around the system during all assembly, installation, maintenance and repair work. • Before applying pressure to the system, check all pipe connections and tighten if necessary. • Slowly pressurise the system with compressed gas. • Avoid pressure blows and high differential pressures. • Assemble all pipes without mechanical stress. Avoid any vibrations occurring in the pipe network by using vibration dampers. • Always keep exactly to the installation and operating instructions given in this manual. • Always keep inspection and maintenance interval exactly. • Install fixed pipes as supply and discharge drains. • Do not carry out any structural changes to the product.
DANGER	Use of incorrect spare parts, accessories or installation materials!
	The use of incorrect spare parts, accessories or installation materials, as well as auxiliary and operating materials, may result in death or serious injury. In addition, malfunction and device failure or material damage can occur.
	<ul style="list-style-type: none"> • For all installation, servicing and maintenance work, only use undamaged original parts, auxiliary and operating materials which are specified by the manufacturer. • Only use fittings and connecting elements approved for the respective application as well as suitable tools in perfect operating condition. • Only use cleaned pipes that are free of dirt and corrosion.
WARNING	Non-application of personal protective equipment!
	Non-application of personal protective equipment or the use of sub-standard protective equipment can lead to accidents or personal injuries during work on the product.
	<ul style="list-style-type: none"> • The personal protective equipment recommended, which must be in a flawless condition, must be worn during all work on the product. • Inspect the personal protective equipment regularly for flawlessness and functionality and replace damaged parts immediately.
WARNING	Insufficient qualification!
	Insufficient qualification of the personnel can lead to accidents, personal injury and damage to the device as well as impairments during work on the operating material.
	All work on the product may only be carried out by appropriately qualified skilled personnel.

3. Transport and storage

WARNING	Insufficient qualification!
	<p>Insufficient qualification of the personnel can lead to accidents, personal injury and damage to the device as well as impairments during work on the operating material.</p> <p>The work on the operating material described below must only be executed by specialist personnel during transport and storage.</p>

CAUTION	Inappropriate transport or storage!
	<p>Inappropriate transport or storage may result in personal injury or damage to the device.</p> <ul style="list-style-type: none"> • Wear protective gloves when working with packaging material • Use personal protective equipment, inspect it regularly for faultlessness and functionality and replace damaged parts immediately. • The operating material may only be transported or stored by qualified personnel. • Handle packaging and operating material with care. • Pack all parts impact-proof using suitable material. • Transport and handle the packaging according to the markings (observe lifting gear attachment points, the centre of gravity and orientation e.g. keep vertical, do not throw etc.). • Use proper means of transport and lifting equipment that is in proper working order. • Always adhere to the specified transport and storage parameters. • Store the operating material only outside of areas exposed to direct sunlight and heat sources.

NOTE	Handling packaging material!
	<p>Inappropriate disposal of packaging materials can cause environmental damage.</p> <ul style="list-style-type: none"> • The packaging material is recyclable. • Dispose of the packaging material in accordance with the regional laws, provisions, guidelines and regulations of the country and place of use.

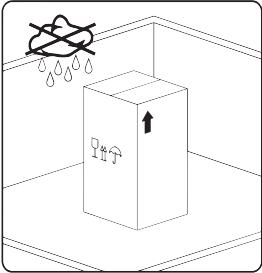
NOTE	Note for transport and storage!
	<p>The operating material must be</p> <ul style="list-style-type: none"> • stored in the original packaging and retained in a dry as well as frost-free room. The ambient parameters, transport and storage parameters must never fall short of/exceed the specifications in the technical data chapter. • Always protect it against external weathering effects even in a packaged condition. • Secure the plant so that it cannot topple over or fall and protect it against vibration at the storage location.

4. Product information

4.1 Product description

CLEARPOINT® water separators are designed for the separation of drops of liquid and solid particles in compressed gas systems.

The condensate accumulated during separation can be discharged manually or automatically.

4.2 Product overview

The separator is made up of the following components:

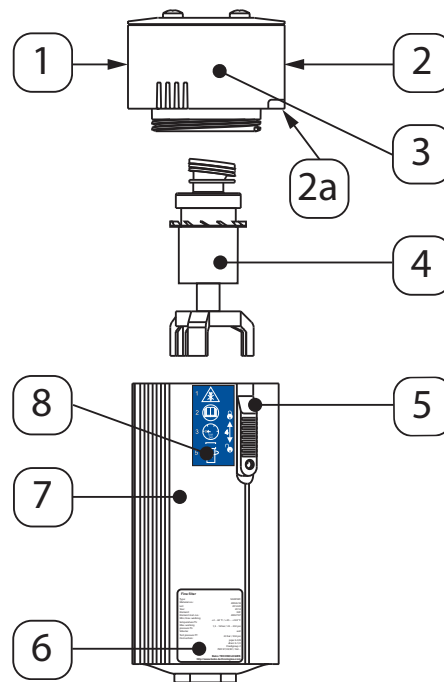

Position no.	Explanation/description
[1]	Inlet on the separator head
[2]	Outlet on the separator head marked additionally by 2a
[3]	Housing head
[4]	Water separator insert (WS-insert)
[5]	Safety slide with locking screw
[6]	Type plate
[7]	Housing body
[8]	Maintenance label

4.3 Product identification

The product designation is shown on the type plate and made up of numbers and letter codes. Each code stands for a separator component and is divided into the following categories:

- [1] = Size: Housing
- [2] = WS-insert
- [3] = Attachment components top
- [4] = Attachment components bottom

The product designation is explained below using the example “S040WWB”:

1
2
3
4
S040WWB

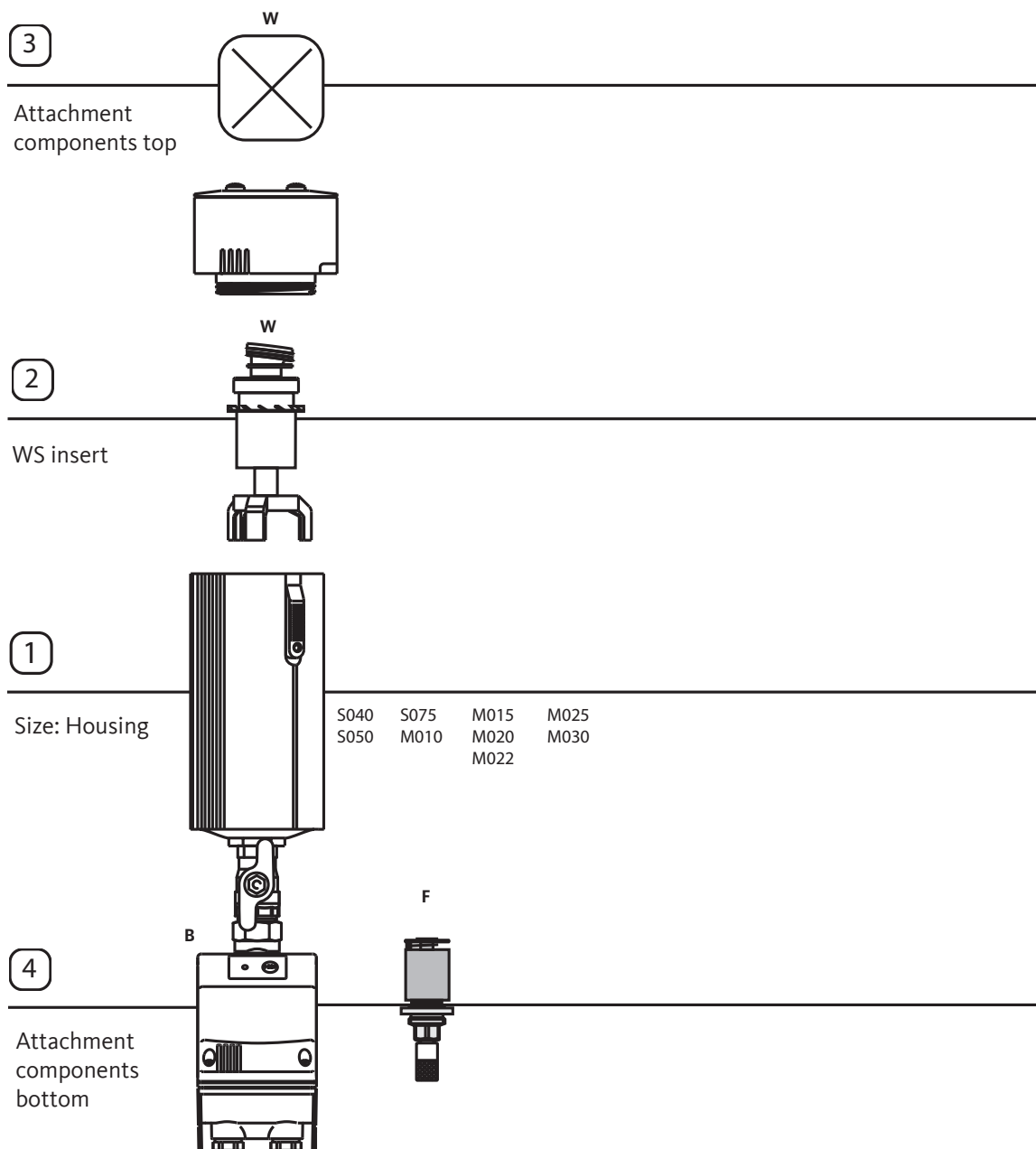

Attachment components top		
Position no.	Letter code	Designation
[3]	W	Without indicator unit

Water separator inserts		
Position no.	Letter code	Designation
[2]	W	Water separator

Position no.	Model series	Construction size	Designation
[1]	S	040	Housing size
	S	050	
	S	075	
	M	010	
	M	015	
	M	020	
	M	022	
	M	025	
	M	030	

Attachment components bottom		
Position no.	Letter code	Designation
[4]	B	BEKOMAT® 20
	F	Float drain, open when pressureless (NO - normally open)

4.4 Function description

4.4.1 Water separation

The compressed gas enters the water separator through the inlet on the separator head **[1]**. A specially shaped spin insert **[2]** makes the compressed gas start rotating quickly. The resulting centrifugal forces press the condensate particles against the outer wall of the housing. Gravity makes the condensate particles flow downwards into the collecting space **[3]** from where they are discharged.

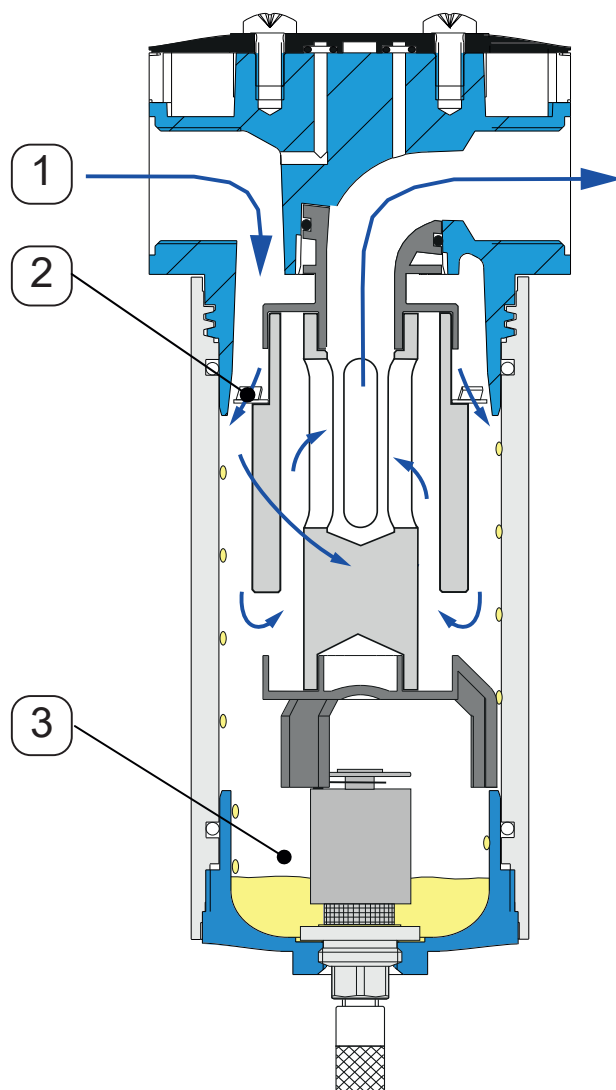

4.4.2 Condensate discharge through float drain

Float drains are mechanical condensate drains that work automatically as they are closed and opened based on the buoyancy of a float body [1]. When the condensate [2] in the container rises to a certain level, buoyant force pushes the float body [1] up and opens the outlet channel [3] for the condensate. The float body closes again when the condensate [2] drops to below a certain level. A small amount of condensate remains in the container.

Two different float drains are used for discharging the condensate:

- Open when pressureless ([NO] normally open) - at operating pressure ≤ 0.5 bar(g) the float drain opens
- Closed when pressureless ([NC] normally closed) - the float drain remains closed even at operating pressure 0 bar(g)

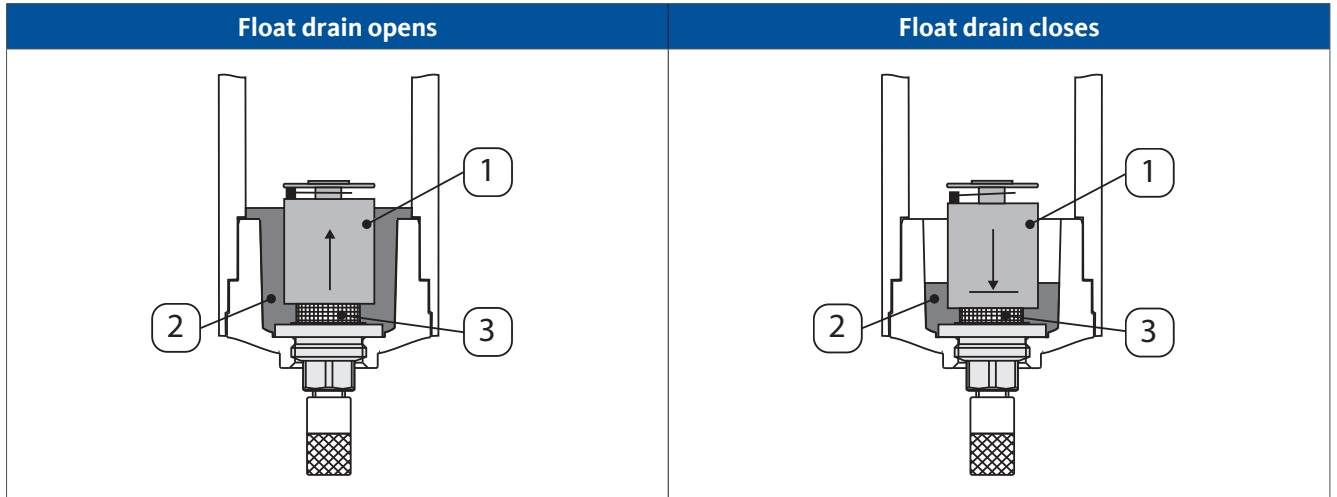

Both types of float drain are delivered with the position »Automatic discharge« from the factory. The knurled screw is screwed downwards as far as it will go.

To test the discharge function or relieve the pressure on the separator during maintenance work, the float drain can be set to the position »mechanically open«. Screw the knurled screw anti-clockwise (left-hand thread) upwards as far as it will go.

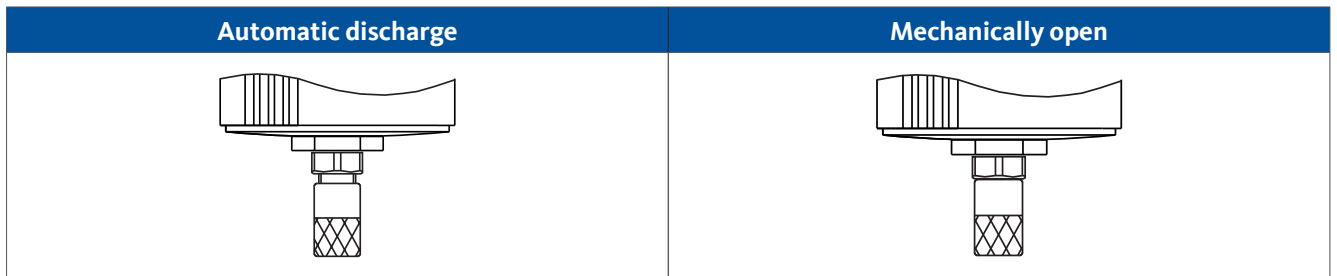

INFORMATION	Condensate discharge!
	Condensate discharge depends on the product combination and can vary.



For further information on possible product combinations see “4.3 Product identification” on Page 14.

4.4.3 Condensate discharge through BEKOMAT

Condensate discharge can also take place via the automatic BEKOMAT® condensate drain. More detailed information can be found in the installation and operation manual for the BEKOMAT®.

4.5 Scope of delivery

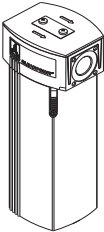
The following table shows the scope of delivery of the separator.

Illustration	Description/Explanation
	<p>Separator</p>
	<p>Installation and operation manual</p>

INFORMATION	Possible product combinations!
	<p>The scope of delivery can vary depending on the product combination.</p>

For further information on possible product combinations see “4.3 Product identification” on Page 14.

4.6 Type plate

The type plate contains the identification and operating parameters of the separator and is located on the housing. If you contact the manufacturer or supplier, always have this data ready for system identification.

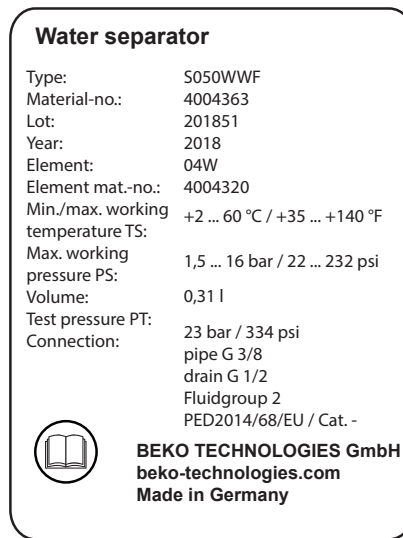

Example:

Position on type plate	Description
Water separator	BEKO separator designation
Model:	Sales designation
Material no.	Material number
Lot	Lot number
Year	Year of manufacturer
Element	Water separator insert
Element mat.-no.:	Material number water separator insert
Min./max. working temperature TS	Min./Max. Operating temperature range
Max.working pressure PS	Max. working pressure range
Volume	Housing volume
Test Pressure PT	Test pressure
Connection	Thread connections
pipe G 1/2	Thread connection of supply pipe
drain G 1/2	Thread connection of condensate drain
Fluidgroup 2	Fluid group according to Pressure Equipment Directive 2014/68/EU
PED2014/68/EU / Cat. -	Specification of the category according to Pressure Equipment Directive 2014/68/EU

NOTE	Handling the type plate!
	Never damage, remove or make the type plate illegible.

For more information regarding the symbols printed on the type plate, see “1.4 Explanation of the symbols and pictograms utilised” on Page 5.

4.7 Stamp on water separator insert

The WS-insert can be identified by means of a stamp on the bottom of the element.

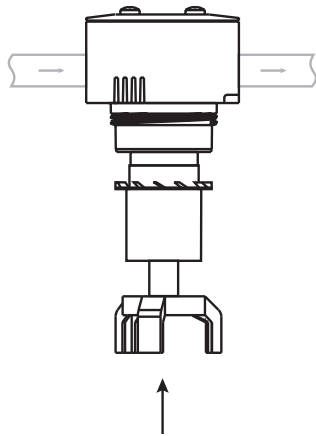

Stamp on the bottom of the WS-insert

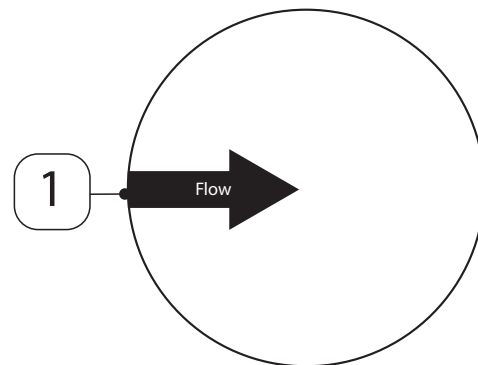

Stamp on water separator insert - View of the bottom of the element

Position no.	Explanation/description
[1]	Direction of flow

5. Technical data

5.1 Separator performance data

CLEARPOINT®	S040	S050	S075	M010	M015
Connection [inches]	3/8	1/2	3/4	1	1 1/2
Volume flow at 7 bar(g) energy-optimised [m ³ /h] ^{*1}	46	130	195	325	545
Differential pressure [mbar] wet-saturated	Ø 60				
Category according to PED 2014/68/EU	-	-	-	-	-
Min./Max. Operating pressure [barg]	1.5 ... 16				
Min./Max. Operating temperature [°C]	+2 ... +60				
Load test according to AD2000	10000 load changes Δ pressure difference \geq 3.2 bar at 16 bar(g)				
Medium	Compressed gases of fluid group 2 according to PED 2014/68/EU free of aggressive and corrosive components				
Weight [kg]	0.75	0.85	1.7	2.1	4.1
Volume [l]	0.25	0.31	0.87	1.12	2.52

^{*1} Volume flow at 7 bar(g) referring to +20 °C and 1 bar(abs)

CLEARPOINT®	M020	M022	M025	M030
Connection [inches]	2	2	2 1/2	3
Volume flow at 7 bar(g) energy-optimised [m ³ /h] ^{*1}	1015	1325	2100	3120
Differential pressure [mbar] wet-saturated	Ø 60			
Category according to PED 2014/68/EU	I	I	II	II
Min./Max. Operating pressure [barg]	1.5 ... 16			
Min./Max. Operating temperature [°C]	+2 ... +60			
Load test according to AD2000	10000 load changes Δ pressure difference ≥ 3.2 bar at 16 bar(g)			
Medium	Compressed gases of fluid group 2 according to PED 2014/68/EU free of aggressive and corrosive components			
Weight [kg]	5.1	6.1	19.9	25.9
Volume [l]	3.40	4.23	13.9	19.5

^{*1} Volume flow at 7 bar(g) referring to +20 °C and 1 bar(abs)

5.2 Materials

Component	Material
Housing head (separator head)	S040 ... M012: Aluminium (die-cast), anodised, powder-coated M015 ... M030: Aluminium (sand casting), anodised, powder-coated
Housing body	S040 ... M030: Aluminium (extruded profile), anodised, powder-coated
Housing cover	Polyamide PA6, 30 % glass fibre reinforced
Housing base	S040 ... M012: Aluminium (die-cast), anodised, powder-coated M015 ... M030: Aluminium (sand casting), anodised, powder-coated
M5 screws	Steel, black galvanised
Slide	Zinc (die-cast), seal FKM
O-rings	Standard: NBR oil-free: FKM
Float drain-off conduit	Plastic brass NBR
Manual condensate drain	Brass
Wall bracket	Stainless steel
Adhesive label	Soft PVC, polyacrylate adhesive
BEKOMAT®	See the installation and operating manual for the BEKOMAT®
Differential pressure gauge	See the installation and operating manual for the differential pressure gauge
Oil indicator	See the installation and operating manual for the oil indicator
WS-insert	Polyamide PA6, 30 % glass fibre reinforced Polyamide PA6 E natural Expanded stainless steel



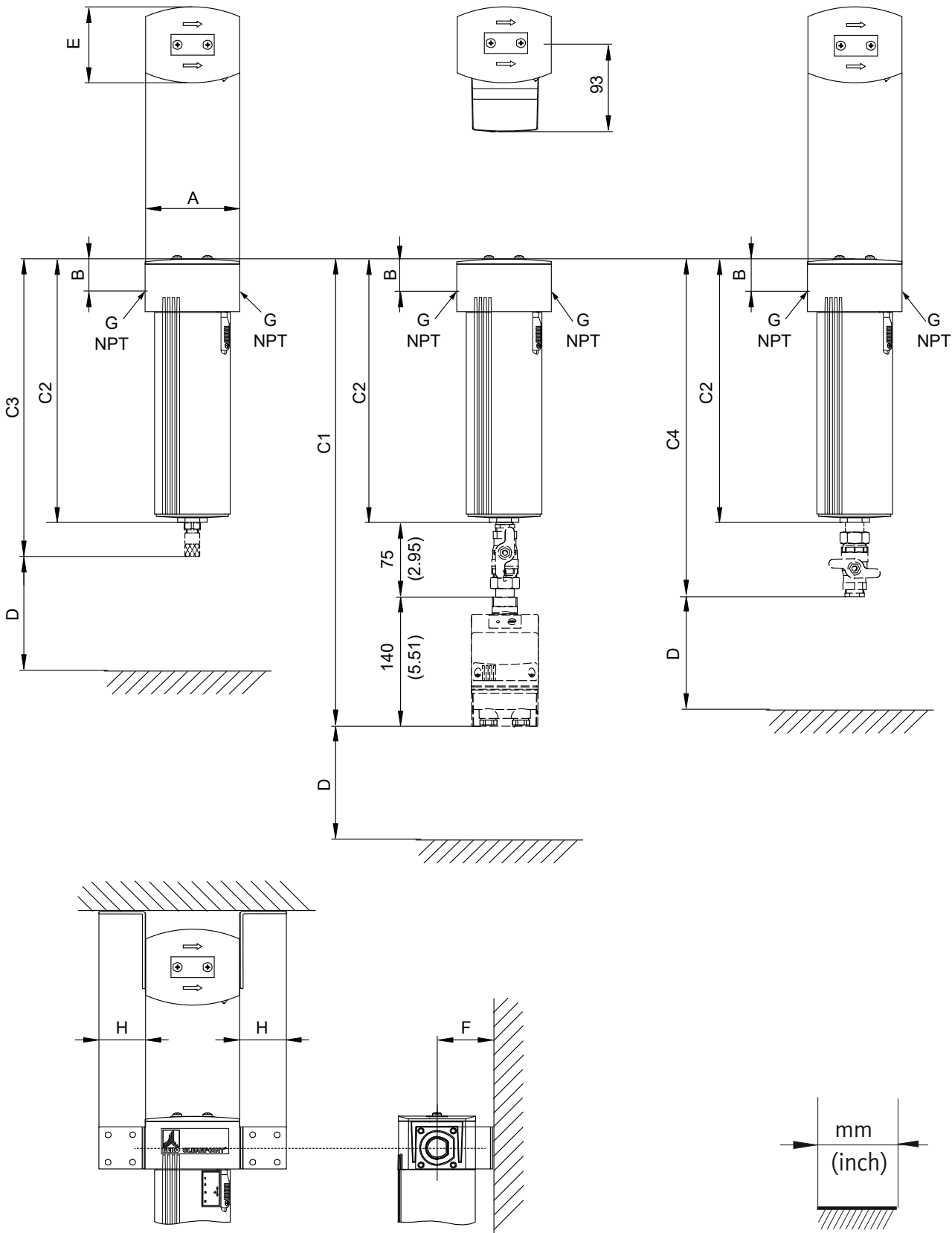

6. Dimensions



Separator	Connection thread	A	B	C1	C2	C3	C4	D	E	F	H	WS-insert
	G / NPT [inches]	[mm]	[mm]	[mm]	[mm]	[mm]	[mm]	[mm]	[mm]	[mm]	[mm]	
S040 (type)	3/8	75	28	395	180	208	243	150	60	64.5	39.5	04 W
S050 (type)	1/2	75	28	425	210	238	273	150	60	64.5	39.5	05 W
S075 (type)	3/4	100	34	495	280	308	343	150	80	63	45	07 W
M010 (type)	1	100	34	565	350	378	413	150	80	63	45	10 W
M015 (type)	1 1/2	146	48	580	365	384	428	200	120	78.5	60	15 W
M020 (type)	2	146	48	683	468	487	531	200	120	78.5	60	20 W
M022 (type)	2	146	48	780	565	584	628	200	120	78.5	60	22 W
M025 (type)	2 1/2	260	77	886	671	684	734	300	200	130	120	25 W
M030 (type)	3	260	77	1010	895	908	958	300	200	130	120	30 W

7. Assembly

7.1 Warning notices

DANGER	Use of incorrect spare parts, accessories or installation materials!
	<p>The use of incorrect spare parts, accessories or installation materials, as well as auxiliary and operating materials, may result in death or serious injury. In addition, malfunction and device failure or material damage can occur.</p>
	<ul style="list-style-type: none"> • For all installation, servicing and maintenance work, only use undamaged original parts, auxiliary and operating materials which are specified by the manufacturer. • Only use fittings and connecting elements approved for the respective application as well as suitable tools in perfect operating condition. • Only use pipes that are free of dirt, damage and corrosion.
DANGER	Pressurised system!
	<p>Death or serious personal injury can result through contact with fast or suddenly escaping compressed air or through bursting system parts</p>
	<ul style="list-style-type: none"> • All work on the system must be carried out in the depressurised state and with the system secured against unintentional pressure build-up. • Set up a safety zone around the system during all assembly, installation, maintenance and repair work. • Before applying pressure to the system, check all pipe connections and tighten if necessary. • Slowly pressurise the system with compressed gas. • Avoid pressure blows and high differential pressures. • Assemble all pipes without mechanical stress. Avoid any vibrations occurring in the pipe network by using vibration dampers. • The pipes must be able to bear the additional weight of the separator. Additional fixings must be mounted if necessary. • Always keep exactly to the installation and operating instructions given in this manual. • Always keep inspection and maintenance interval exactly. • Install fixed pipes as supply and discharge drains. • Do not carry out any structural changes to the product.
WARNING	Insufficient qualification!
	<p>Insufficient qualification of the personnel can lead to accidents, personal injury and damage to the device as well as impairments during work on the operating material.</p>
	<p>All work on the product may only be carried out by appropriately qualified skilled personnel.</p>
CAUTION	Inappropriate assembly!
	<p>Inappropriate assembly of the product can lead to personal injury and product damage as well as impair operation.</p>
	<ul style="list-style-type: none"> • The direction of flow of the separator must match the direction of flow in the pipe. • The separator must be fitted vertically in the pipe.

7.2 Assembly work

For assembly work to be carried out, the following prerequisites must be fulfilled and the preparatory tasks must have been completed.

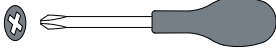
Prerequisites		
Tools	Material	Protective equipment
<ul style="list-style-type: none"> Screwdriver - cross-head size 2.5 mm 	<ul style="list-style-type: none"> Additional installation and operating manual for the accessories used Sealing materials such as e.g. PTFE tape (EN 837-2) 	<ul style="list-style-type: none"> Protective gloves (fluid-resistant) Safety goggles with side shields Hearing protection Respiratory protection, protection class FFP 3 Safety footwear

Preparation of installation	
1.	Remove the dust cap from the following threads: <ul style="list-style-type: none"> Inlet and outlet on the housing head Condensate drain on the housing base
2.	Depressurise the pipelines or relevant pipe section.
3.	Note the separator dimensions and make sure there is sufficient space for set up. See "6. Dimensions" on Page 24.
4.	Pipes must be able to bear the additional weight of the separator. Additional fixings must be mounted if necessary.
5.	Pipes must be free of contamination and corrosion. Check pipe thread for damage. Defective pipes must be replaced immediately.
6.	Pipes must be free of mechanical stress and corrosion. Compensate any vibrations which occur by using vibration dampers.
7.	Only use fittings which are suitable for this pressure and temperature range. The pipe threads must match those of the housing head.
8.	Execute the condensate drain in such a way that no compressed gas or condensate can escape to the surrounding of the separator. The condensate to be discharged should be routed to a processing system conforming to law (e.g. ÖWAMAT® or BEKOSPLIT®).

The direction of flow of the separator must be taken into account during set up. It must be adapted to the direction of flow in the pipe.

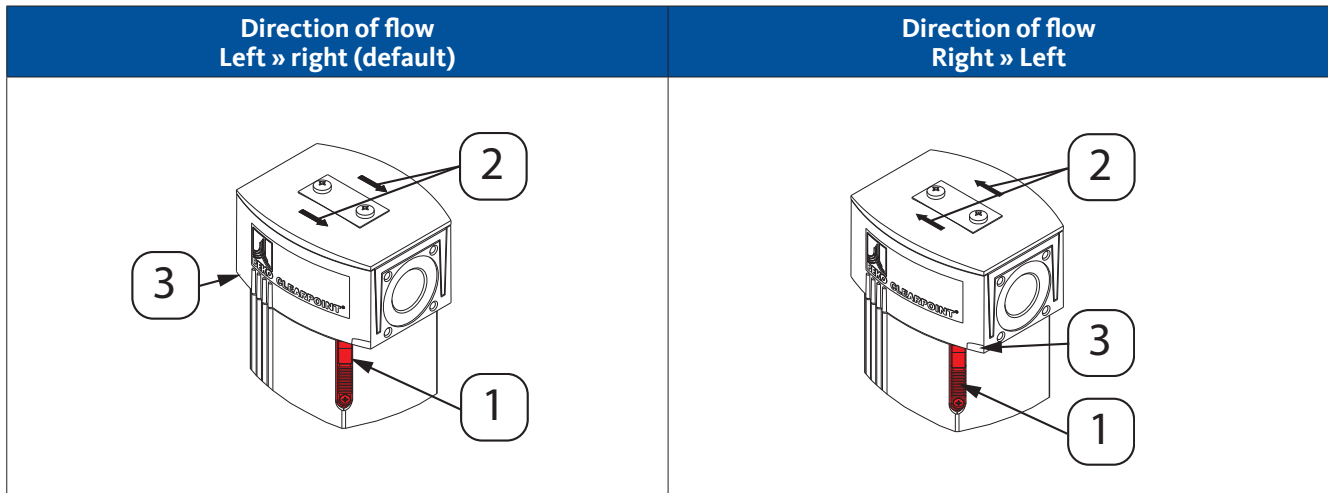

The housing head and the housing body are equipped with a double-start trapezoidal thread. The direction of flow of the separator can be adapted to the direction in the pipe by turning the housing head through 180°. The direction of flow is indicated by arrows [2] and a raised marking [3] on the housing head. These must be aligned as shown. The safety slide [1] must always be in an easily accessible position on the front.

The fitting of a bypass pipe [4] and corresponding shut-off valves [5] is recommended for maintenance and servicing work.

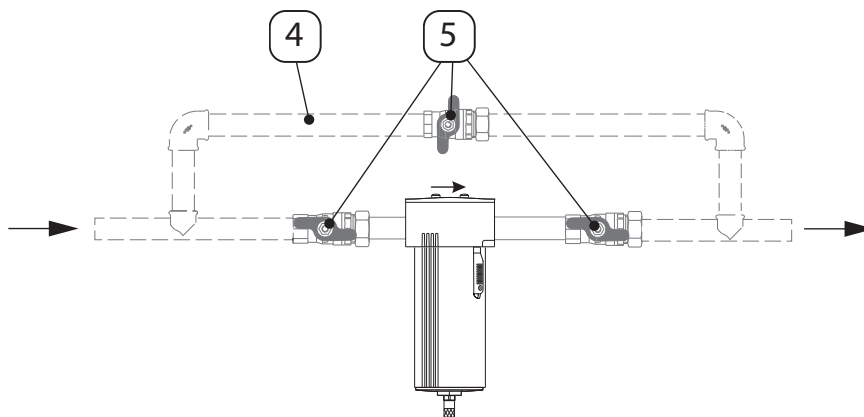

1. Apply sealing material e.g. PTFE-tape (EN 837-2) to the pipe ends
2. Screw the pipe thread into the separator outlet until the connection is firm and leak-tight
3. Screw the pipe thread into the separator outlet until the connection is firm and leak-tight

After assembly work has been finished, it must be checked whether the housing body has been screwed in properly, the safety slide pushed up and the safety screw tightened hand-tight. A leakage test should be carried out to check the assembly work. For additional information, refer to “9.6 Leakage test” on Page 39.

8. Commissioning

8.1 Commissioning tasks

For commissioning to be carried out, the following prerequisites must be fulfilled and the preparatory tasks must have been completed.

Prerequisites		
Tools	Material	Protective equipment
<ul style="list-style-type: none"> • none 	<ul style="list-style-type: none"> • none 	<ul style="list-style-type: none"> • None

Preparation of installation	
1.	Assembly finished including subsequent leakage test

Illustration		Description
Automatic discharge	Mechanically open	
		<ol style="list-style-type: none"> 1. Set the knurled screw on the float drain from >>Mechanically open<< anti-clockwise (left-hand thread) to >>Automatic discharge<<

Illustration	Description
	<ol style="list-style-type: none"> 2. Open the shut-off valve [1] on the inlet side slowly 3. Open the shut-off valve [2] on the outlet side slowly 4. Close the shut-off valve [3] of the bypass pipe



9. Maintenance and servicing

9.1 Maintenance schedule

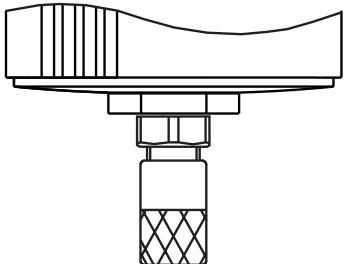
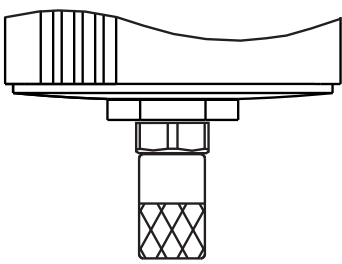
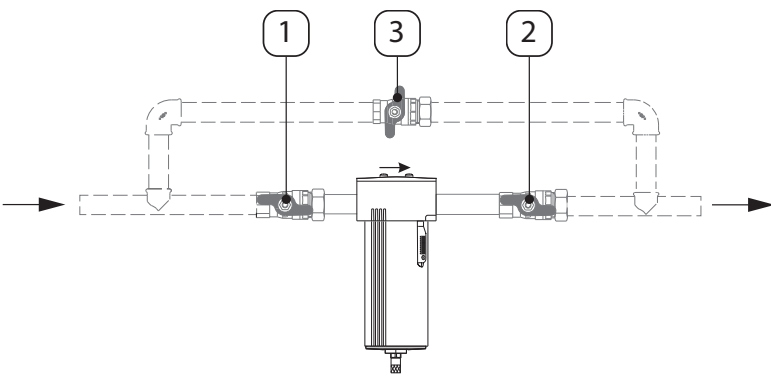
Maintenance	Interval
Cleaning work	At regular intervals, depending on the degree of contamination
Visual inspection	Weekly
Replace the float drain	Annually
Replace the WS-insert	If damaged
Leakage test	Recommended interval: At the end of all assembly work and maintenance and servicing work on the product

9.2 Cleaning

9.2.1 Warning notices

CAUTION	Inappropriate cleaning and use of the wrong cleaning media!
	<p>Inappropriate cleaning and the use of the wrong cleaning media may result in minor injuries as well as damage to health and property.</p> <ul style="list-style-type: none"> • Never clean the device with a wet cloth. • Never use abrasive or aggressive cleaning agents or solvents which could damage the outer coating (e.g. markings, type plate, corrosion protection, etc.). • Never clean the device with hard or pointed implements. • For external cleaning, use a dust brush or damp cotton cloths that cannot become statically charged. • Immediately replace operating material labels (pictograms, markings) that have become illegible.
NOTE	Local hygiene regulations!
	In addition to the cleaning instructions listed, any local hygiene regulations which are in place must be heeded.

9.2.2 Cleaning work

For cleaning to be carried out, the following prerequisites must be fulfilled and the preparatory tasks must have been completed.

Prerequisites		
Tools	Material	Protective equipment
<ul style="list-style-type: none"> • none 	<ul style="list-style-type: none"> • Mild detergent • Cotton cloth or disposable tissue 	<ul style="list-style-type: none"> • Protective gloves (fluid-resistant) • Safety goggles with side shields • Hearing protection • Respiratory protection, protection class FFP 3 • Safety footwear

To clean the separator, use a damp (but not wet) cotton cloth or disposable tissue and a mild conventional detergent or soap.

1. Spray a little detergent onto the clean cotton cloth or disposable tissue.
2. Wipe down the entire surface of the component.
3. The final drying is accomplished with a clean cloth or through air drying.

9.3 Visual inspection



During the visual inspection of the separator, all components must be inspected for mechanical damage and corrosion. Any damaged components must be replaced immediately.

9.4 Replace the float drain

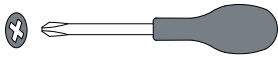
For float drain replacement to be carried out, the following prerequisites must be fulfilled and the preparatory tasks must have been completed.

Prerequisites		
Tools	Material	Protective equipment
<ul style="list-style-type: none"> Screwdriver - cross-head size 2.5 mm 	<ul style="list-style-type: none"> New float drain with adapter enclosed 	<ul style="list-style-type: none"> Protective gloves (fluid-resistant) Safety goggles with side shields Hearing protection Respiratory protection, protection class FFP 3 Safety footwear

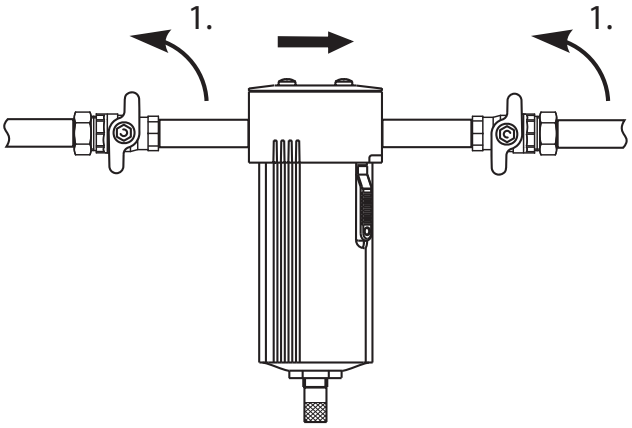
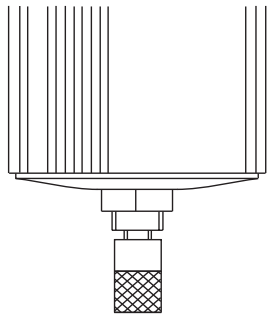
Preparation of installation	
1.	Open the bypass pipe if available

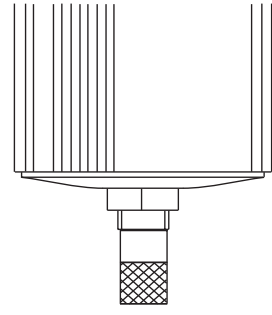
Illustration	Description
	<p>1. Close the shut-off valves upstream and downstream of the separator or the respective system section</p>
<div style="display: flex; justify-content: space-around;"> <div style="text-align: center;">  <p>2. </p> <p>Automatic discharge</p> </div> <div style="text-align: center;">  <p>Mechanically open</p> </div> </div>	<p>2. Set the knurled screw on the float drain anti-clockwise (left-hand thread) from >>Automatic discharge<< to >>Mechanically open<<</p>

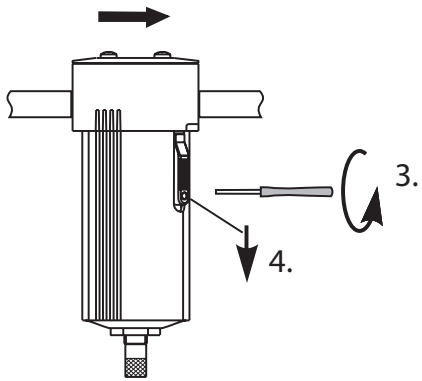

- 3. Undo the locking screw on the safety slide
- 4. Push the safety slide downwards

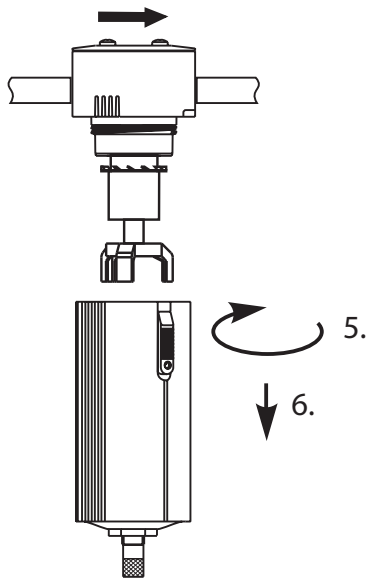

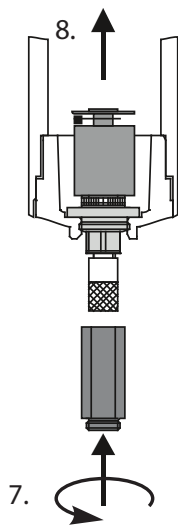

- 5. Unscrew the housing body
- 6. Pull the housing body down and off

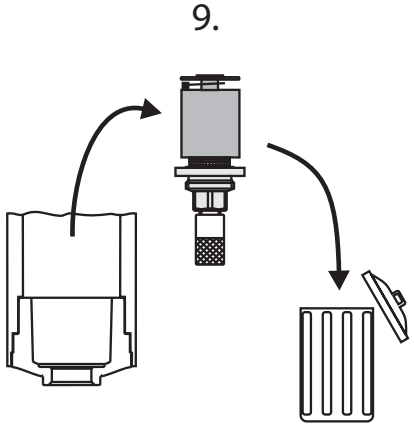
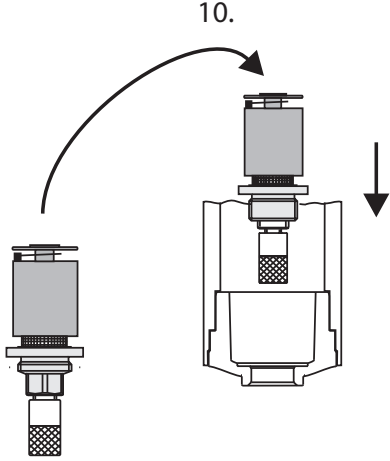
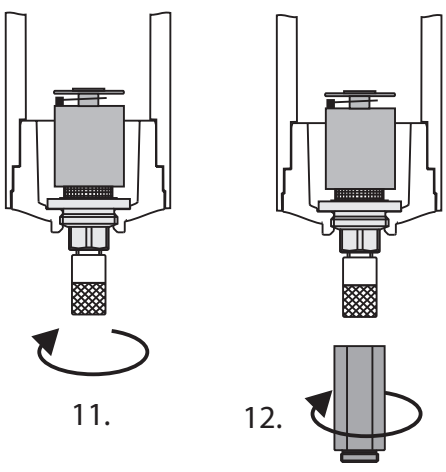

- To screw the float drain out, use the size 13 adapter enclosed with the float drain.
- 7. Use the adapter to screw the float drain out anti-clockwise
 - 8. Lift the float drain out of the top of the housing body

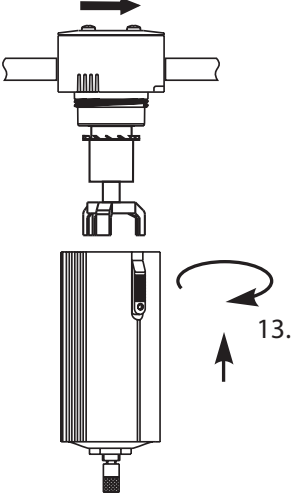
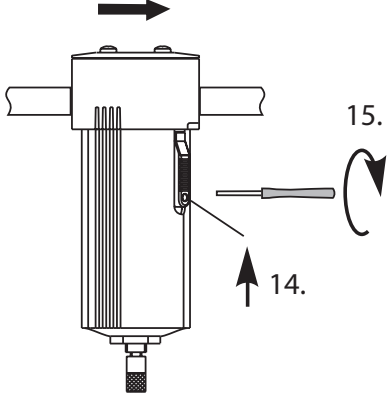
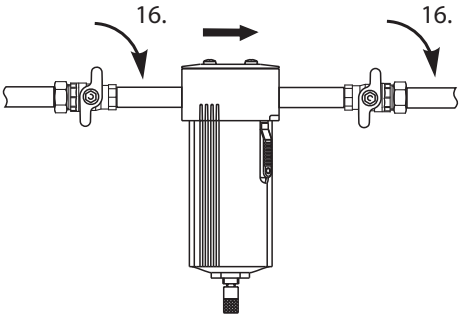
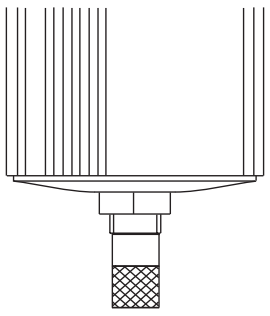
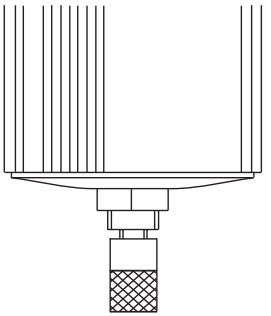
 <p>9.</p>	<p>9. Dispose of the float drain properly and in line with the regional requirements.</p> <p>For more information, see “12. Disposal” on Page 44.</p>
 <p>10.</p>	<p>10. Insert a new float drain into the housing body</p>
 <p>11.</p> <p>12.</p>	<p>11. Screw the float drain into the housing body clockwise by hand</p> <p>12. Tighten the float drain using the adapter</p>

	<p>13. Screw the housing body back onto the housing head Make sure that the safety slide is facing the front after set up.</p>
	<p>14. Push the safety slide upwards 15. Tighten the locking screw on the safety slide</p>
	<p>16. Slowly open the shut-off valves upstream and downstream of the separator or the respective system section</p>
<div style="display: flex; justify-content: space-around;"> <div data-bbox="183 1646 454 1960">  <p>Mechanically open</p> </div> <div data-bbox="518 1646 790 1960">  <p>17.  Automatic discharge</p> </div> </div>	<p>17. Set the knurled screw on the float drain anti-clockwise (left-hand thread) from >>Mechanically open<< to >>Automatic discharge<< by unscrewing the knurled screw as far as it will go</p>

9.5 Replacing the water separator insert

For the water separator insert to be replaced, the following prerequisites must be fulfilled and the preparatory tasks must have been completed.

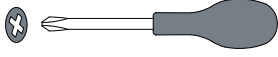
Prerequisites		
Tools	Material	Protective equipment
<ul style="list-style-type: none"> Screwdriver - cross-head size 2.5 mm 	<ul style="list-style-type: none"> New WS-insert 	<ul style="list-style-type: none"> Protective gloves (fluid-resistant) Safety goggles with side shields Hearing protection Respiratory protection, protection class FFP 3 Safety footwear

Preparation of installation	
1.	Open the bypass pipe if available

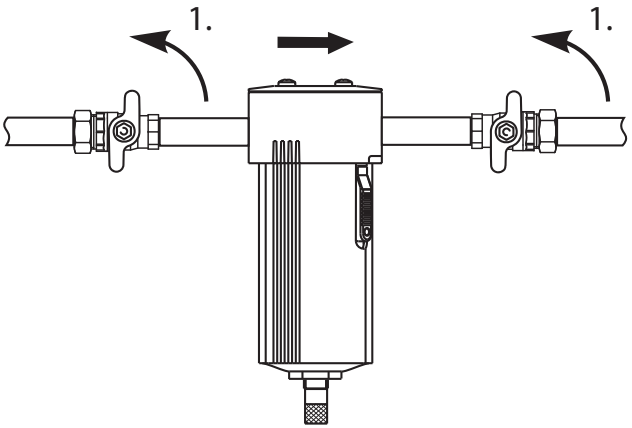
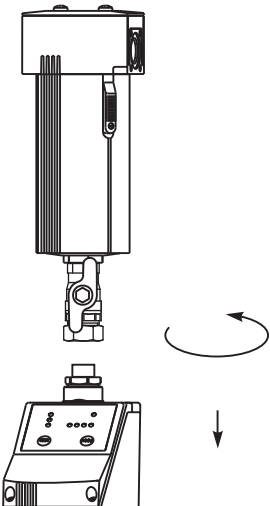
Illustration	Description
	<p>1. Close the shut-off valves upstream and downstream of the separator or the respective system section and depressurise the filter</p>
	<p>2. When the BEKOMAT® is used, it must be disconnected from the bottom part of the housing.</p> <p>For further information see the enclosed installation and operating manual for the BEKOMAT®</p>

	<p>3. Undo the locking screw on the safety slide 4. Push the safety slide downwards</p>
	<p>5. Unscrew the housing body 6. Pull the housing body down and off</p>
	<p>7. Pull the used WS-insert down and out of the housing head</p>

	<p>8. Insert the new WS-insert into the housing head. Take care that the sloped surface on the WS-insert is sloped downwards towards the compressed air outlet.</p>
	<p>9. Screw the housing body to the housing head Make sure that the safety slide is facing the front.</p>
	<p>10. Push the safety slide upwards 11. Tighten the locking screw on the safety slide</p>

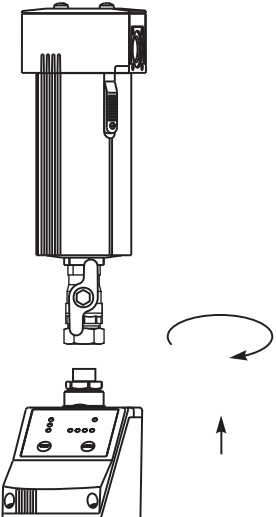
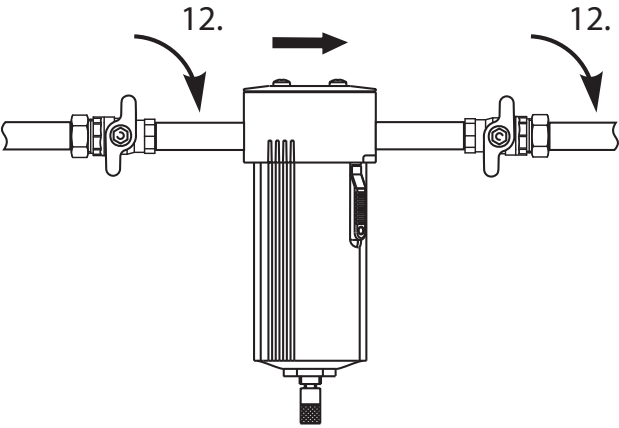
	<p>12. When the BEKOMAT® is used it must be reconnected</p> <p>For further information see the enclosed installation and operating manual for the BEKOMAT®</p>
	<p>13. Slowly open the shut-off valves upstream and downstream of the separator or the respective system section</p>

9.6 Leakage test

The leakage test is a non-destructive test method and is used to prove leak tightness in vacuum and overpressure systems. The leakage test can be carried out in different ways. **BEKO TECHNOLOGIES GMBH** does not make a specific recommendation here. The company operating the compressed gas system is responsible for the selection and specification of the test method to be used, which should be carried out in accordance with valid standards and regulations (e.g. DIN EN 1779).

10. Decommissioning

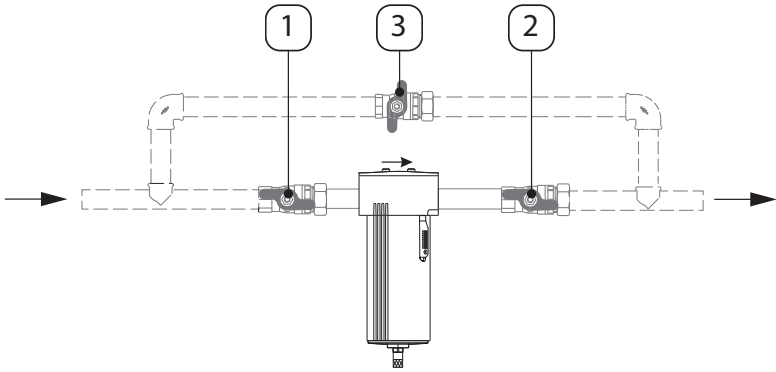
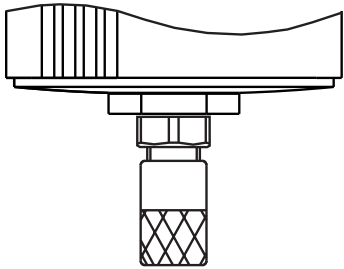
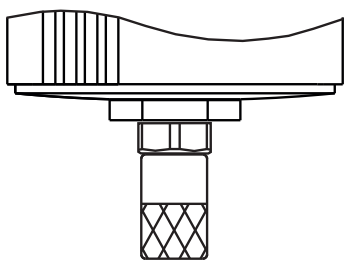



Illustration	Description
	<ol style="list-style-type: none"> 1. Open the shut-off valve [3] of the bypass pipe (if available) 2. Close the shut-off valve [2] on the outlet side 3. Close the shut-off valve [1] on the inlet side

Illustration		Description
Automatic discharge	Mechanically open	
		<ol style="list-style-type: none"> 4. Set the knurled screw on the float drain anti-clockwise (left-hand thread) from >>Automatic discharge<< to >>Mechanically open<< or press the BEKOMAT® TEST button until the separator is pressureless

11. Disassembly

11.1 Warning notices

DANGER	Use of incorrect accessories, materials or spare parts!
	<p>The use of incorrect spare parts, accessories or installation materials, as well as auxiliary and operating materials, may result in death or serious injury. In addition, malfunction and device failure or material damage can occur.</p> <ul style="list-style-type: none"> • For all disassembly work, only use undamaged original parts, auxiliary and operating materials which are specified by the manufacturer. • Only use fittings and connecting elements approved for the respective application as well as suitable tools in perfect operating condition.
DANGER	Compressed air
	<p>Death or serious personal injury can result through contact with fast or suddenly escaping compressed air or through bursting system parts</p> <ul style="list-style-type: none"> • All work on the system must be carried out in the depressurised state and with the system secured against unintentional pressure build-up. • Set up a safety zone around the system during all assembly, installation, maintenance and repair work. • Before applying pressure to the system, check all pipe connections and tighten if necessary. • Slowly pressurise the system with compressed gas. • Avoid pressure blows and high differential pressures. • Assemble all pipes without mechanical stress. Avoid any vibrations occurring in the pipe network by using vibration dampers. • Always keep exactly to the installation and operating instructions given in this manual. • Always keep inspection and maintenance interval exactly. • Install fixed pipes as supply and discharge drains. • Do not carry out any structural changes to the product.
WARNING	Insufficient qualification!
	<p>Insufficient qualification of the personnel can lead to accidents, personal injury and damage to the device as well as impairments during work on the operating material.</p> <p>The work on the product described below may only be executed and documented by qualified personnel for compressed gas technology.</p>

11.2 Disassembly work

For disassembly to be carried out, the following prerequisites must be fulfilled and the preparatory tasks must have been completed.

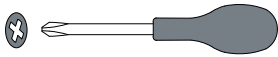
Prerequisites		
Tools	Material	Protective equipment
<ul style="list-style-type: none"> Screwdriver - cross-head size 2.5 mm 	<ul style="list-style-type: none"> none 	<ul style="list-style-type: none"> Protective gloves (fluid-resistant) Safety goggles with side shields Hearing protection Respiratory protection, protection class FFP 3 Safety footwear

Preparation of installation	
1.	Open the bypass pipe if available

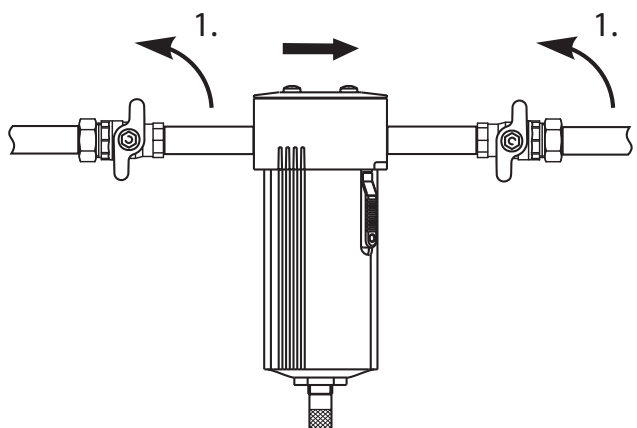
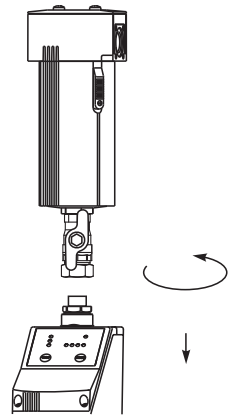

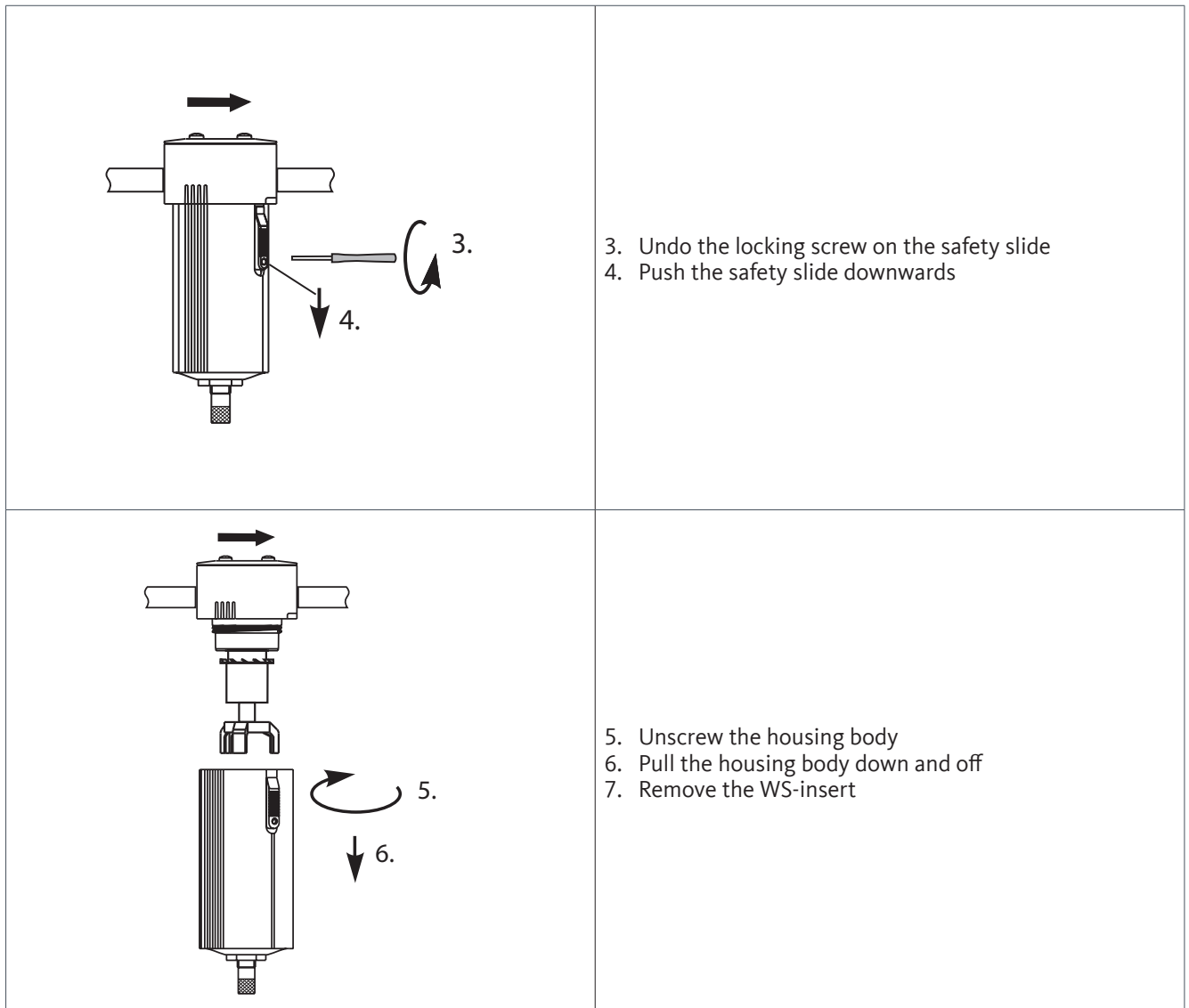
Illustration	Description
	<p>1. Close the shut-off valves upstream and downstream of the separator or the respective system section, depressurise the separator and secure the system against unintentional pressure build-up</p>
	<p>2. When the BEKOMAT® is used, it must be disconnected from the bottom part of the housing</p> <p>For further information see the enclosed installation and operating manual for the BEKOMAT®</p>



8. Remove the housing head from the pipe and seal the ends of the pipe properly
9. Dispose of the components properly

12. Disposal

12.1 Warning notices

DANGER	Use of incorrect accessories, materials or spare parts!
	<p>The use of incorrect spare parts, accessories or installation materials, as well as auxiliary and operating materials, may result in death or serious injury. In addition, malfunction and device failure or material damage can occur.</p> <ul style="list-style-type: none"> • For all disassembly work, only use undamaged original parts, auxiliary and operating materials which are specified by the manufacturer. • Only use fittings and connecting elements approved for the respective application as well as suitable tools in perfect operating condition.
NOTE	Inappropriate disposal!
	<p>Inappropriate disposal of parts and components, operating and auxiliary materials as well as cleaning media can cause environmental damage.</p> <ul style="list-style-type: none"> • Dispose of all parts and components, operating and auxiliary materials as well as cleaning media professionally and in accordance with regional legal provisions, regulations and requirements. • In case of uncertainties regarding disposal, always consult a regional waste management company.

12.2 Disposal work

At the end of its useful life, the product must be disposed of properly e.g. by a specialist company. Materials as glass, plastics and some chemical compounds are mostly recoverable, reusable, or recyclable.

All national and local regulations must be kept during disposal.

Used WS-insert:

Do not dispose of as household waste! Disposal must be carried out properly and in line with environmental requirements.

Used float drain:

Do not dispose of as household waste! Disposal must be carried out properly and in line with environmental requirements.

13. Spare parts and accessories

13.1 Spare parts

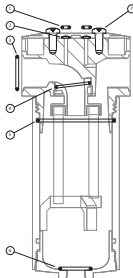
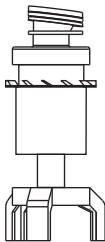
Designation	Illustration	Separate documentation
O-ring kit for S040, S050 → 4026562 O-ring kit for S075, M010 → 4026563 O-ring kit for M015, M020, M022 → 4026564 O-ring kit for M025, M030 → 4026565		Enclosed instruction leaflet
WS-insert 04 W → 4004320 WS-insert 05 W → 4004321 WS-insert 07 W → 4004322 WS-insert 10 W → 4004323 WS-insert 15 W → 4004324 WS-insert 20 W → 4007102 WS-insert 22 W → 4004325 WS-insert 25 W → 4004326 WS-insert 30 W → 4004327		Enclosed instruction leaflet

13.2 Accessories attachment components top

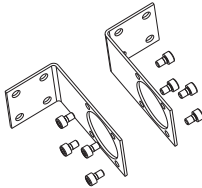
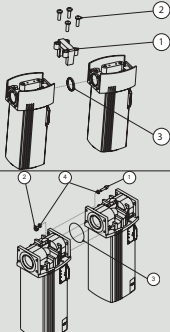
Designation	Illustration	Separate documentation
Wall bracket for S040, S050 → 4003328 Wall bracket for S075, M010 → 4003329 Wall bracket for M015, M020, M022 → 4003330 Wall bracket for M025, M030 → 4003331		None
Connecting kit for S040, S050 → 403332 Connecting kit for S075, M010 → 403333 Connecting kit for M015, M020, M022 → 403334 Connecting kit for M025, M030 → 403335		Enclosed instruction leaflet

13.3 Accessories attachment components bottom

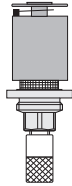
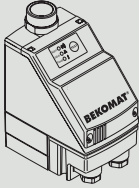
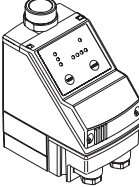
Designation	Illustration	Separate documentation
Float drain (opened when pressureless) → 4025536 Float drain (closed when pressureless) → 4025537		Enclosed instruction leaflet
BEKOMAT® 20 → 4001841		Enclosed installation and operation manual
BEKOMAT® 20 Vario → 4004010		Enclosed installation and operation manual

14. Fault and trouble shooting / FAQ

Error or fault pattern	Possible causes	Remedy
Poor compressed gas quality	Excessive load, load surges	<ul style="list-style-type: none"> • Change operating method • Avoid pressure surges • Observe the prescribed operating parameters, particularly during start-up processes
	Non-functioning condensate discharge	<ul style="list-style-type: none"> • Guarantee regular condensate discharge
	Incorrect dimensioning	<ul style="list-style-type: none"> • Dimension the separator according to the given operating parameters and replace if necessary
	WS-insert fitted incorrectly	<ul style="list-style-type: none"> • Note the direction of flow / direction of installation of the WS-insert
	O-ring has been damaged during installation	<ul style="list-style-type: none"> • Procure O-ring kit, proceed carefully during installation
High differential pressure	Incorrect dimensions	<ul style="list-style-type: none"> • Dimension the separator according to the given operating parameters and replace by larger one if necessary
	Destroyed WS-insert	<ul style="list-style-type: none"> • Replace the WS-insert
Condensate in downstream components	Condensate drain defective or malfunctioning	<ul style="list-style-type: none"> • Replace float drain or carry out maintenance on BEKOMAT®
Leakage	Ageing seals	<ul style="list-style-type: none"> • Replace seals within the context of maintenance work
	Mechanical damage	<ul style="list-style-type: none"> • Send in the separator for repair or replace by a new one

15. Product approvals and registration marks

Symbol/Pictogram	Description/Explanation
	CE marking on the separator Applicable for sizes M020, M022, M025, M027, M030 und M032

BEKO TECHNOLOGIES GMBH
Im Taubental 7
41468 Neuss

GERMANY

Tel: +49 2131 988-0
www.beko-technologies.com



Herstellererklärung

Wir erklären hiermit, dass die nachfolgend bezeichneten Produkte, in den von uns gelieferten Ausführungen gemäß Druckgeräterichtlinie 2014/68/EU Artikel 4 Absatz 3 in Übereinstimmung mit der geltenden guten Ingenieurpraxis ausgelegt und hergestellt werden.

Produktbezeichnung:	Behälter für Wasserabscheider CLEARPOINT®
Baugrößen:	S040W, S050W, S075W, M010W, M015W
Max. Betriebsdruck:	16 bar (g)

Beschreibung der Druckgeräte: Druckgeräte für Fluide der Gruppe 2

Druckgeräte nach Artikel 4 Absatz 3 der Druckgeräterichtlinie 2014/68/EU dürfen nicht die in Artikel 19 genannte CE-Kennzeichnung tragen.

Die Behälter wurden einer hydraulischen Druckprüfung mit 23 bar, und einer Dichtheitsprüfung mit dem Medium Druckluft, bei 7,0 bar unterzogen. Bei den durchgeführten Prüfungen zeigten sich keine Mängel.

Unterzeichnet für und im Namen von:

Neuss, 25.03.2019

BEKO TECHNOLOGIES GMBH

i.V. Christian Riedel

Leiter Qualitätsmanagement International

BEKO TECHNOLOGIES GMBH
Im Taubental 7
41468 Neuss

GERMANY

Phone: +49 2131 988-0
www.beko-technologies.com



Manufacturer Declaration

We hereby declare that the products indicated hereafter, in the condition in which they have been placed into circulation, have been designed and manufactured according to sound engineering practice, in compliance with Article 4, Paragraph 3 of the European Pressure Equipment Directive 2014/68/EC.

Product designation: Vessel for water separators CLEARPOINT®
Sizes: S040W, S050W, S075W, M010W, M015W
Max. operating pressure: 16 bar (g)

Description of the pressure equipment: Pressure equipment for fluids of Group 2

Pressure equipment according to Article 4, Paragraph 3 of the European Pressure Equipment Directive 2014/68/EU must not bear the CE marking referred to in Article 19 of the above Directive.

The vessel was subjected to a hydraulic pressure test with 23 bar and a leakage test with a compressed air media at 7.0 bar. The vessel passed both tests successfully and no defects were detected.

Signed for and on behalf of:

Neuss, 25.03.2019

BEKO TECHNOLOGIES GMBH

i.V. Christian Riedel
Head of International Quality Management

BEKO TECHNOLOGIES GMBH
 Im Taubental 7
 41468 Neuss

GERMANY

Tel: +49 2131 988-0
 www.beko-technologies.com



EU-Konformitätserklärung

Wir erklären hiermit, dass die nachfolgend bezeichneten Produkte den Anforderungen der einschlägigen Richtlinien und technischen Normen entsprechen. Diese Erklärung bezieht sich nur auf die Produkte in dem Zustand, in dem sie von uns in Verkehr gebracht wurden. Nicht vom Hersteller angebrachte Teile und/oder nachträglich vorgenommene Eingriffe bleiben unberücksichtigt.

Produktbezeichnung:	Behälter CLEARPOINT® ... für Wasserabscheider
Modelle:	M020W, M022W
Max. Betriebsdruck:	16 bar (g)
Produktbeschreibung und Funktion:	Behälter für CLEARPOINT Wasserabscheider

Druckgeräte-Richtlinie 2014/68/EU

Angewandtes Konformitätsbewertungsverfahren:	Modul A
Kategorie:	I
Beschreibung der Druckgeräte:	Druckgeräte für Fluide der Gruppe 2

Der Hersteller trägt die alleinige Verantwortung für die Ausstellung dieser Konformitätserklärung.

Unterzeichnet für und im Namen von:

Neuss, 22.07.2016

BEKO TECHNOLOGIES GMBH

i.V. Christian Riedel
 Leiter Qualitätsmanagement International

BEKO TECHNOLOGIES GMBH
 Im Taubental 7
 41468 Neuss

GERMANY

Phone: +49 2131 988-0
 www.beko-technologies.com



EU Declaration of Conformity

We hereby declare that the products named below comply with the stipulations of the relevant directives and technical standards. This declaration only refers to products in the condition in which they have been placed into circulation. Parts which have not been installed by the manufacturer and/or modifications which have been implemented subsequently remain unconsidered.

Product designation:	Vessel CLEARPOINT® ... for water separators
Type:	M020W, M022W
Max. operating pressure:	16 bar (g)
Product description and function:	Vessel for CLEARPOINT water separators

Pressure Equipment Directive 2014/68/EU

Applied conformity assessment procedure:	Module A
Category:	I
Description of the pressure equipment:	Pressure equipment for fluids of Group 2

The manufacturer shall have sole responsibility for issuing this declaration of conformity.

Signed for and on behalf of:

Neuss, 14.05.2019

BEKO TECHNOLOGIES GMBH

i.V. Christian Riedel
 Head of International Quality Management

BEKO TECHNOLOGIES GMBH
Im Taubental 7
41468 Neuss

GERMANY

Tel: +49 2131 988-0
www.beko-technologies.com



EU-Konformitätserklärung

Wir erklären hiermit, dass die nachfolgend bezeichneten Produkte den Anforderungen der einschlägigen Richtlinien und technischen Normen entsprechen. Diese Erklärung bezieht sich nur auf die Produkte in dem Zustand, in dem sie von uns in Verkehr gebracht wurden. Nicht vom Hersteller angebrachte Teile und/oder nachträglich vorgenommene Eingriffe bleiben unberücksichtigt.

Produktbezeichnung:	Behälter CLEARPOINT® ... für Wasserabscheider
Modelle:	M025W, M030W
Max. Betriebsdruck:	16 bar (g)
Produktbeschreibung und Funktion:	Behälter für CLEARPOINT Wasserabscheider

Druckgeräte-Richtlinie 2014/68/EU

Angewandtes Konformitätsbewertungsverfahren:	Modul A2
Kategorie:	II
Beschreibung der Druckgeräte:	Druckgeräte für Fluide der Gruppe 2
Notifizierte Stelle:	TÜV NORD Systems GmbH & Co. KG Große Bahnstraße 31 22525 Hamburg
Zertifikatsnummer:	07/202/1410/Z/0237/17/D/0035

Die Produkte sind mit dem abgebildeten Zeichen gekennzeichnet:

CE0045

Der Hersteller trägt die alleinige Verantwortung für die Ausstellung dieser Konformitätserklärung.

Unterzeichnet für und im Namen von:

Neuss, 01.09.2017

BEKO TECHNOLOGIES GMBH

i.V. Christian Riedel
Leiter Qualitätsmanagement International

BEKO TECHNOLOGIES GMBH
 Im Taubental 7
 41468 Neuss

GERMANY

Phone: +49 2131 988-0
 www.beko-technologies.com



EU Declaration of Conformity

We hereby declare that the products named below comply with the stipulations of the relevant directives and technical standards. This declaration only refers to products in the condition in which they have been placed into circulation. Parts which have not been installed by the manufacturer and/or modifications which have been implemented subsequently remain unconsidered.

Product designation:	Vessel CLEARPOINT® ... for water separators
Type:	M025W, M030W
Max. operating pressure:	16 bar (g)
Product description and function:	Vessel for CLEARPOINT water separators

Pressure Equipment Directive 2014/68/EU

Applied conformity assessment procedure:	Module A2
Category:	II
Description of the pressure equipment:	Pressure equipment for fluids of Group 2
Notified body	TÜV NORD Systems GmbH & Co. KG Große Bahnstraße 31 22525 Hamburg Germany
Certificate number:	07/202/1410/Z/0237/17/D/0035

The products bear the CE Mark:

C €0045

The manufacturer shall have sole responsibility for issuing this declaration of conformity.

Neuss, 01.09.2017

Signed for and on behalf of:

BEKO TECHNOLOGIES GMBH

i.V. Christian Riedel
 Head of International Quality Management

BEKO TECHNOLOGIES GmbH

Im Taubental 7
 D - 41468 Neuss
 Tel. +49 2131 988 0
 Fax +49 2131 988 900
 info@beko-technologies.com

DE**BEKO TECHNOLOGIES LTD.**

Unit 11-12 Moons Park
 Burnt Meadow Road
 North Moons Moat
 Redditch, Worcs, B98 9PA
 Tel. +44 1527 575 778
 info@beko-technologies.co.uk

GB**BEKO TECHNOLOGIES S.à.r.l.**

Zone Industrielle
 1 Rue des Frères Rémy
 F - 57200 Sarreguemines
 Tél. +33 387 283 800
 info@beko-technologies.fr

FR**BEKO TECHNOLOGIES B.V.**

Veenen 12
 NL - 4703 RB Roosendaal
 Tel. +31 165 320 300
 benelux@beko-technologies.com

NL**BEKO TECHNOLOGIES
(Shanghai) Co. Ltd.**

Rm. 606 Tomson Commercial Building
 710 Dongfang Rd.
 Pudong Shanghai China
 P.C. 200122
 Tel. +86 21 508 158 85
 info.cn@beko-technologies.cn

CN**BEKO TECHNOLOGIES s.r.o.**

Na Pankraci 58
 CZ - 140 00 Praha 4
 Tel. +420 24 14 14 717 /
 +420 24 14 09 333
 info@beko-technologies.cz

CZ**BEKO Tecnológica España S.L.**

Torruella i Urpina 37-42, nave 6
 E - 08758 Cervelló
 Tel. +34 93 632 76 68
 Mobil +34 610 780 639
 info.es@beko-technologies.es

ES**BEKO TECHNOLOGIES LIMITED**

Unit 1010 Miramar Tower
 132 Nathan Rd.
 Tsim Sha Tsui Kowloon Hong Kong
 Tel. +852 5578 6681 (Hong Kong)
 Tel. +86 147 1537 0081 (China)
 tim.chan@beko-technologies.com

HK**BEKO TECHNOLOGIES INDIA
PRIVATE LIMITED**

Plot No.43/1 CIEEP Gandhi Nagar
 Balanagar Hyderabad
 IN - 500 037
 Tel. +91 40 23080275 /
 +91 40 23081107
 Madhusudan.Masur@bekoindia.com

IN**BEKO TECHNOLOGIES S.r.l**

Via Peano 86/88
 I - 10040 Leini (TO)
 Tel. +39 011 4500 576
 Fax +39 0114 500 578
 info.it@beko-technologies.com

IT**BEKO TECHNOLOGIES K.K**

KEIHIN THINK Building 8 Floor
 1-1 Minamiwatarida-machi
 Kawasaki-ku, Kawasaki-shi
 JP - 210-0855
 Tel. +81 44 328 76 01
 info@beko-technologies.jp

JP**BEKO TECHNOLOGIES Sp. z o.o.**

ul. Pańska 73
 PL - 00-834 Warszawa
 Tel. +48 22 314 75 40
 info.pl@beko-technologies.pl

PL**BEKO TECHNOLOGIES S.E.Asia
(Thailand) Ltd.**

75/323 Soi Romklao, Romklao Road
 Sansab Minburi
 Bangkok 10510
 Tel. +66 2-918-2477
 info.th@beko-technologies.com

TH**BEKO TECHNOLOGIES Co.,Ltd**

16F.-5 No.79 Sec.1
 Xintai 5th Rd., Xizhi City
 New Taipei City 221
 Taiwan (R.O.C.)
 Tel. +886 2 8698 3998
 info.tw@beko-technologies.tw

TW**BEKO TECHNOLOGIES CORP.**

900 Great Southwest Pkwy SW
 US - Atlanta, GA 30336
 Tel. +1 404 924-6900
 Fax +1 (404) 629-6666
 beko@bekousa.com

US