



EN - english

Instructions for installation and operation

Pressure transducer METPOINT[®] PRM

SP21 / SP22

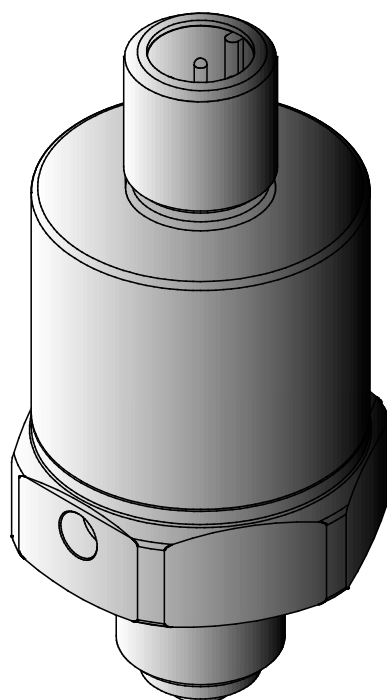

Dear customer,

Thank you for deciding in favour of the METPOINT® PRM SP21 / SP22 pressure transducer. Please read these installation and operating instructions carefully before mounting and starting up the pressure transducer and follow our directions.

Perfect functioning of the pressure transducer can only be guaranteed when the provisions and notes stipulated here are strictly adhered to.

Contents

1	Pictograms and symbols	4
2	Signal words in accordance with ISO 3864 and ANSI Z 535.....	4
3	General information.....	5
4	Safety instructions	6
5	Proper use.....	7
6	Exclusion from the field of application.....	7
7	Type plate.....	8
8	Technical data	9
9	Dimension drawings	12
10	Function.....	14
11	Installation	15
11.1	Installation instructions.....	15
11.2	Preparing the thread at the measurement point	16
11.3	Installation example for connections in accordance with EN 837-1 with a cylindrical thread	16
12	Electrical installation.....	17
12.1	Pin assignment PRM SP21, 2-wire system	18
12.2	Pin assignment PRM SP22, 4-wire system	18
12.3	Pin assignment PRM SP22, 3-wire system	19
13	Maintenance and calibration	21
13.1	Cleaning/decontamination.....	22
14	Scope of delivery.....	23
15	Accessories	24
16	Dismantling and disposal	25
17	Troubleshooting and fault removal.....	26
18	Declaration of conformity	27
19	Index.....	28

Pictograms and symbols

1 Pictograms and symbols



Observe the installation and operating instructions



General advice



Observe the installation and operating instructions
(on the type plate)



General danger symbol (danger, warning, caution)



Use protective gloves

2 Signal words in accordance with ISO 3864 and ANSI Z 535

Danger!	Imminent hazard Consequences of non-observance: serious injury or death
Warning!	Potential hazard Consequences of non-observance: possible serious injury or death
Caution!	Imminent hazard Consequences of non-observance: possibly injury or property damage
Notice!	Potential hazard Consequences of non-observance: possibly injury or property damage
Important!	Additional advice, info, hints Consequences of non-observance: disadvantages during operation and maintenance, no danger

3 General information

**Warning!****Risk of injury when used incorrectly!**

Prior to the mounting, start-up, and operation of the pressure transducer, it must be ensured that the device was correctly chosen with regard to the measuring range, design and specific measurement conditions. In the event of non-observance, severe personal injury and/or damage to materials may occur.

**Warning!****Risk of injury in the event of insufficient qualifications!**

Improper use can lead to significant personal injury and material damage. All of the activities described in these operating instructions must only be carried out by qualified personnel with the qualifications described hereinafter.

Qualified personnel

Due to the specific training and knowledge concerning the measuring and control technology, and due to their experience and knowledge of the country-specific provisions, standards in force and directives, qualified personnel are capable of carrying out the described work and of independently identifying the possible risks. Special employment conditions require further corresponding knowledge, e.g. regarding aggressive media.



Please check, prior to reading the operating instructions, whether or not these instructions correspond to the device. Read these installation and operating instructions carefully prior to any intervention regarding the METPOINT® PRM. The operating instructions must be accessible at all times at the place of application of the device.

If you have any queries regarding these instructions, please contact BEKO TECHNOLOGIES GMBH.

Installation works must exclusively be carried out by authorised and qualified personnel. Prior to undertaking any measures, the qualified personnel shall read up on the device by carefully studying the operating instructions. The operator of the products is responsible for the adherence to these provisions. The respective directives in force apply to the qualification and expertise of the qualified personnel.

For safe operation, the device must only be installed and operated in accordance with the indications in the operating instructions. In addition, the national and operational statutory provisions and safety regulations, as well as the accident prevention regulations required for the respective case of application, need to be observed during employment. This applies accordingly when accessories are used.

Safety instructions

4 Safety instructions



Danger!
Compressed air!

Risk of serious injury or death through contact with quickly or suddenly escaping compressed air or through bursting plant components.

Measures

- Do not exceed the max. operating pressure (see type plate)!
- Only use pressure-resistant installation material!
- Make sure that no persons or objects can be hit by emerging compressed air!



Danger!
Inadmissible operating parameters!

Under-running or exceeding the limit values involves risks for persons and the material, and malfunction and service failures may occur.

Measures

- Make sure that the pressure transducer is operated only within the permissible limit values that are indicated on the type plate and in the technical data.
- Exact compliance with the performance data of the pressure transducer in connection with the case of application.
- Carry out service and calibration measures at regular intervals.

Further safety advice:

- During installation and operation, the national regulations and safety instructions in force also need to be observed.
- The pressure transducer must not be employed in hazardous areas.

Additional instructions

- Do not overheat the device!
- The pressure transducer must not be disassembled!



Caution!
Damage possible!

Using the pressure transducer with corrosive media involves the risk of premature technical failure.

Measures

- Only use the device with the media that are listed in the data sheet and in the technical data.



Note:

The resistance at the double permissible max. operating pressure is confirmed.
For further information, please refer to the enclosed technical data sheet.

5 Proper use

The **METPOINT® PRM** pressure transducer detects the relative pressure (gauge pressure) in **gaseous** and **liquid** media and transforms this measured value into a linear output signal 4 ... 20 mA or 0 ... 10 V.

Pressure transducers transform the physical pressure into a **pressure-proportional** electrical signal. Depending on the version, there are different measuring principles which form the basis of the pressure monitoring.

The **METPOINT® PRM** pressure transducer is exclusively designed and constructed for the proper application purpose that is described herein and must be used correspondingly.

A check in order to ascertain whether or not the device is suitable for the chosen employment must be carried out by the user. It must be ensured that the medium is compatible with the components which come into contact with it. **The technical data listed in the data sheet are binding.**

Improper handling or operation outside the technical specifications is impermissible. **Claims of any kind on the basis of improper use are excluded.**

6 Exclusion from the field of application

- The device is **not** suitable for use in hazardous areas.
- The device is **not** suitable for application with corrosive gases.
- Corrosive fluids must **not** be conducted through the pressure transducer.
- Improper handling or operation outside the technical specifications.

Type plate

7 Type plate

The type plate is on the housing. It includes all the important data regarding the METPOINT® PRM pressure transducer which must be communicated to the manufacturer or supplier upon request.

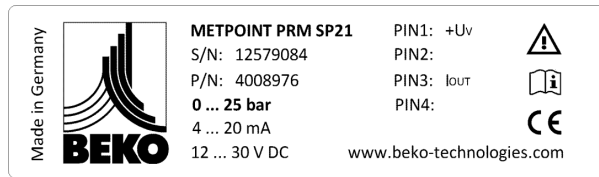

METPOINT® PRM	Product designation
S/N:	Serial number
P/N:	Item number
0 ... 25 bar	Measuring range
4 ... 20 mA	Output signal
12 ... 30 V DC	Supply voltage
PIN 1:	Power supply (U _v +)
PIN 2:	
PIN 3:	Current output (I _{out})
PIN 4:	



Note:

Never remove, damage, or obliterate the type plate!

8 Technical data

	
General indications	
Model designation	PRM SP21 / PRM SP22
Measuring principle	Stainless-steel thin film technology
Measured parameter	Overpressure (gauge pressure)
Output signal, type PRM SP21	4 ... 20 mA , analogue, 2-wire
Output signal, type PRM SP22	0 ... 10 V , analogue, 4- or 3-wire
Measuring range	0 ... 25 bar
Overload pressure limit	50 bar
Burst pressure	125 bar
Process medium ¹	Gases/fluids
Temperature-compensated range	0 ... 60 °C
Reference conditions	EN 61298-1
Process connection (connection pin acc. to EM 837-1)	G¼ B
Weight	105 g
Service life	10 million load alterations
Protection class acc. to EN 60529 ²	IP 67
Nonlinearity after limit point setting ³	≤ ± 0.15% MBE ⁵
Max. error of measurement ⁴	≤ ± 0.5% MBE ⁵

¹ **Process medium**

Compressed air, nitrogen, water, oil, and other fluids of group 2 according to Article 9, Clause 2.2 of the PED 97/23/EC. Group 2 comprises fluids which are **not** toxic, flammable, potentially explosive, and fire-promoting. The process medium must be compatible with the materials 1.4404 and 1.4548.

² The indicated protection classes according to EN 60529 only apply when connected, with a mating connector with a corresponding protection class.

³ **Nonlinearity after the limit point setting, according to EN 61298-2**

As regards the **limit point setting**, the reference line passes through the initial and end point of the measured characteristic curve.

⁴ **Max. error of measurement according to EN 61298-2**

including nonlinearity, hysteresis, non-repeatability, and error of measurement of the measuring range final value. Calibrated at a vertical installation position with a downward process connection.

⁵ MBE = Measuring range final value.

Technical data

Materials	
Sensor element (in contact with the medium)	1.4548
Process connection (in contact with the medium)	1.4404, EN 10272, EN 10088-3
Housing	1.4404, EN 10272, EN 10088-3
Mounting connector	CuZn, Au, PA, FKM / EPDM

Permissible temperature ranges	
Process-medium temperature	-40 ... +85 °C
Ambient temperature during operation	-25 ... +85 °C
Storage and transport temperature	-40 ... +85 °C
Ambient humidity	+20 ... +95 % relative humidity, non-condensing

Electrical specifications PRM SP21, PRM SP22		
Supply voltage ¹ U_V		12 ... 30 V DC
Max. power consumption during nominal operation	PRM SP21 (4 ... 20 mA)	630 mW
	PRM SP22 (0 ... 10 V)	300 mW
Current consumption ^{2,3} during nominal operation	PRM SP21 (4 ... 20 mA)	Signal current, max. 21 mA
	PRM SP22 (0 ... 10 V)	10 mA
Load (load resistance) R_L	PRM SP21 (4 ... 20 mA)	$R_L = 571 \Omega$ at 24 V DC
	PRM SP22 (0 ... 10 V)	$R_L \geq 10 \text{ k}\Omega$
Resistance to short-circuiting		Permanent
Reverse voltage protection ⁴		Available
Insulation resistance		> 100 M Ω at 500V DC
Voltage proof		500 V AC
Overvoltage arrester		36 DC

V AC = V alternating current

V DC = V direct current

¹ **The nominal value of the supply voltage is 24 V DC.**

Supply to the pressure transducer should be implemented with a stabilised, short-circuit-protected power supply that is protected against overvoltage.

The energy supply to the pressure transducer must come from a source with an **energy-limited electrical circuit** (10A max./ 30V max.) and a protective separation from the network. **See EN 61010-1, Clause 9.4.**

² The indications are related to nominal operation.

³ The protection against excess current is realised via a resettable PTC fuse.

⁴ Reverse voltage protection. In the event that the connections are interchanged, the sensor will not be damaged, but the sensor has no function.

Mechanical stresses	
Vibration resistance/vibrations according to EN 60068-2-6	25 ... 2000 Hz, 20 g, sine
Mechanical shock resistance according to EN 60068-2-27	50 g, 11 ms, half-sine

CE conformity	
Pressure Equipment Directive ¹	97/23/EC
EMC Directive	2004/108/EC
EMC immunity to interference, industrial field	EN 61326-1 & EN 61326-2-3
EMC emitted interference (emission), group 1, class B	EN 61326-1
CE labelling according to the EMC Directive 2004/108/EC	

Electrical connections	
Connector (cable box) according to EN 61076-2-101	M12 x1 (4-pole)
Type of connection	Screw terminal
Wire cross-section	max. 0.75 mm ² (AWG 18)
Grommet	4 ... 6 mm
Protection class	IP 67 according to EN60529

¹ For gases and fluids of fluid group 2, the requirements according to Article 3, Clause 3 (good engineering practice) are met.

Dimension drawings

9 Dimension drawings

Dimensions PRM SP21, PRM SP22

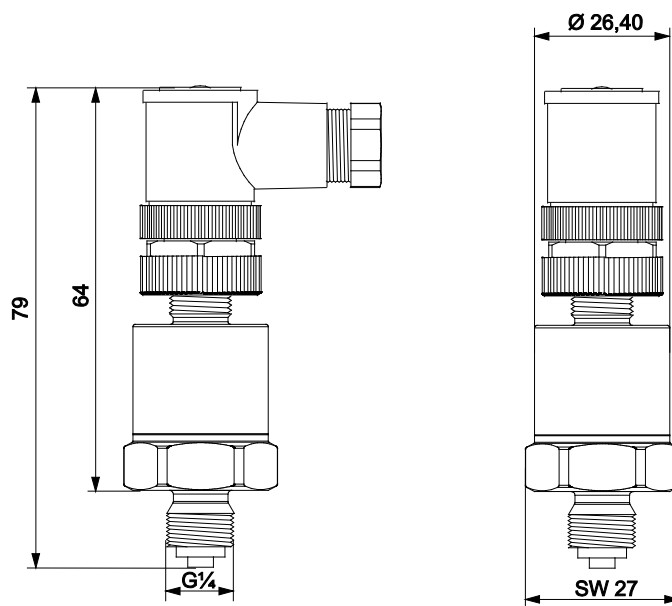
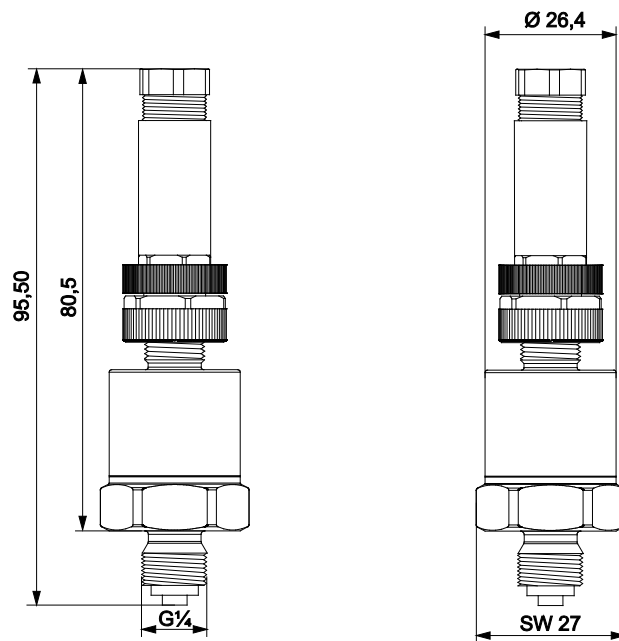

Dimensions and connections PRM SP21, PRM SP22

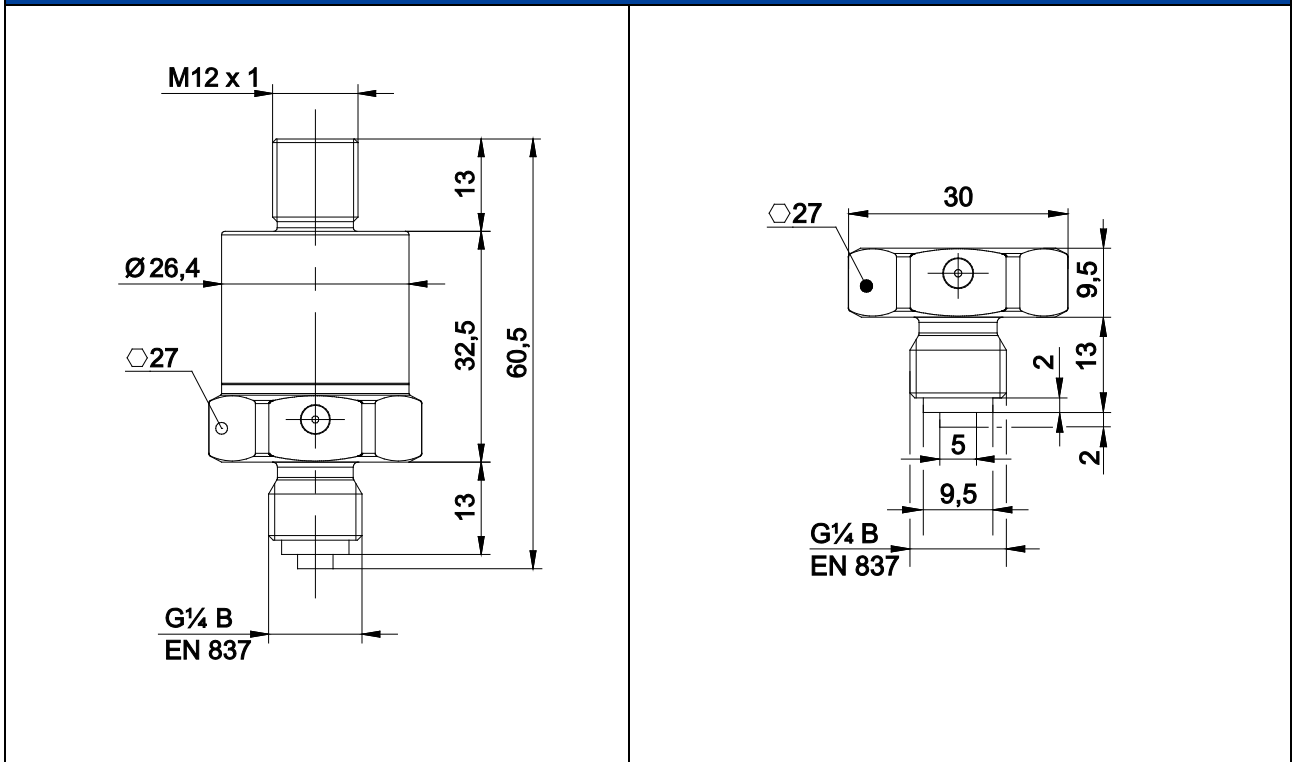

Connection adapter, R $\frac{1}{4}$ and $\frac{1}{4}$ -NPT, width A/F 27

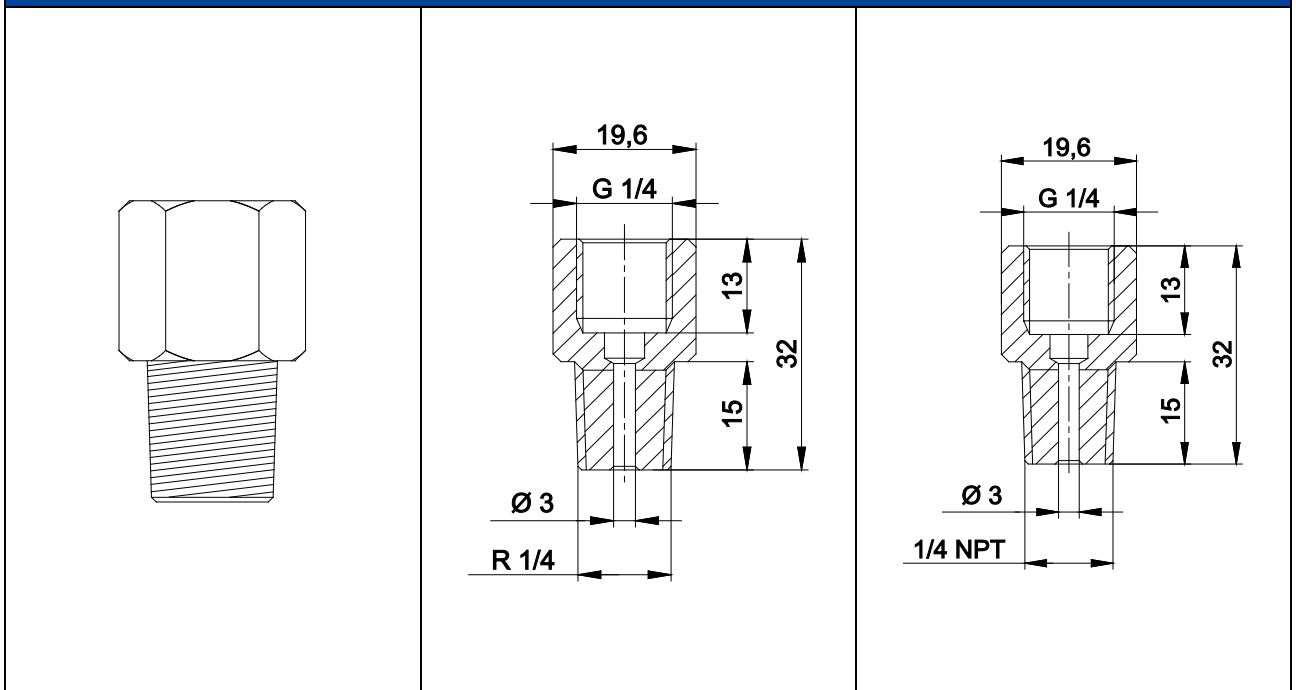

Standards for threads

Straight pipe thread (internal and external screw thread) for a non-sealing connection in the thread
Short symbol **G**, according to **ISO 228-1**

Tapered external pipe thread for a sealing connection in the thread
Short symbol **R**, according to **EN 10026-1**

Tapered external pipe thread for a sealing connection in the thread
Short symbol **NPT**, according to **ANSI/ASME B1.20.1**

10 Function

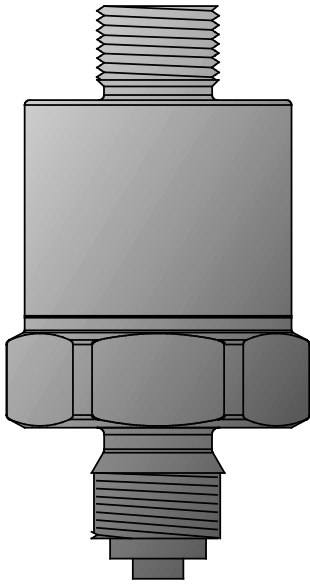

The **METPOINT**[®] pressure transducer of the PRM-SP series detects the relative pressure (gauge pressure) in **gaseous** and **liquid** media and transforms this measured value into a linear, pressure-proportional electrical output signal of 4 ... 20 mA or 0 ... 10 V.

As regards the **METPOINT**[®] **PRM**, sensors of the thin-film technology are employed.

The body and membrane consist of 1.4548 stainless-steel material. On the membrane side that faces away from the medium, insulation layers, **strain gauges**, compensating resistors, and conductors are applied with a combination of chemical and physical methods, and are photolithographically structured through etching. The layers of the resistors and electrical conductors applied on the sensor are considerably thinner than a micrometer and are, therefore, called **thin-film resistors**.

Due to the materials used, the **metal thin-film sensor** boasts very good resistance to many media and it is insensitive to shocks and vibration impacts.

Since the employed materials are easily weldable, the sensor is hermetically welded onto the pressure connection, without needing additional sealing material.

11 Installation

11.1 Installation instructions



Warning!

Risk of injury in the event of insufficient qualifications!

Improper use can lead to significant personal injury and material damage. All of the activities described in these operating instructions must only be carried out by qualified personnel with the qualifications described hereinafter.

Qualified personnel

Due to the specific training and knowledge concerning the measuring and control technology, and due to their experience and knowledge of the country-specific provisions, standards in force and directives, qualified personnel are capable of carrying out the described work and of independently identifying the possible risks. Special employment conditions require further corresponding knowledge, e.g. regarding aggressive media.



Danger!

Compressed air!

Risk of serious injury or death through contact with quickly or suddenly escaping compressed air or through bursting and/or unsecured plant components.

Measures:

- **Only carry out installation works when the system is pressureless.**
- Only use pressure-resistant installation material.
- Do not exceed the max. operating pressure (see type plate).
- Check the installation point for tightness subsequent to installation.



Warning!

Risk of injury through temperature!



Risk of injury through the contact with very high or low temperatures.

Measures:

- Prior to installation or removal of the pressure transducer, carry out a temperature compensation or wear protective gloves.



Caution!

Malfunction at the pressure transducer!

Through incorrect installation, malfunctions may occur at the METPOINT[®] PRM pressure transducer. These can lead to incorrect measuring results and to misinterpretations.



Note:

It is imperative to observe all of the listed hazard and warning notes.

Please also observe all the provisions and instructions regarding the occupational safety and fire at the respective point of installation.

As a matter of principle, only use suitable tools and material in a proper condition.

Bear in mind that condensates can contain aggressive and harmful components. Therefore, avoid contact with the skin.

Installation

11.2 Preparing the thread at the measurement point

In order to install the pressure transducer, a receiving thread is required at the measuring point. The latter must already show the following specifications or must be prepared correspondingly:

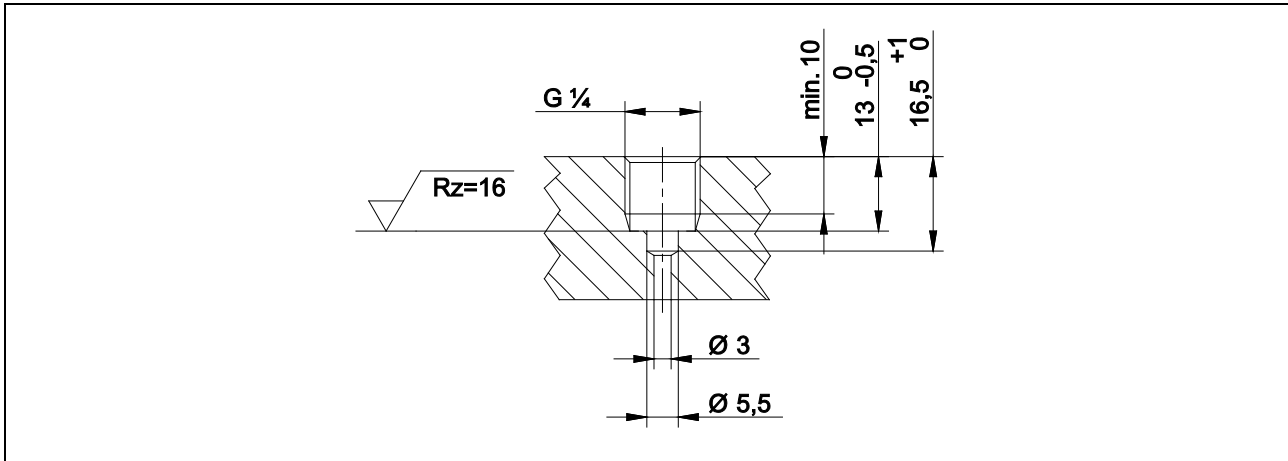

11.3 Installation example for connections in accordance with EN 837-1 with a cylindrical thread

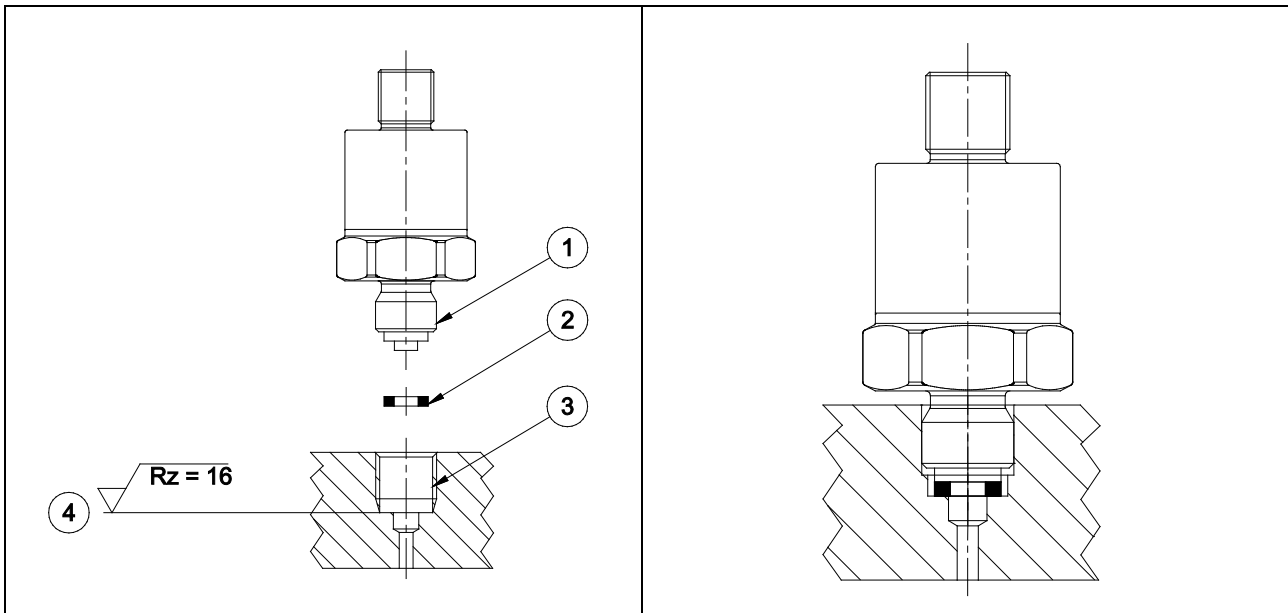

In order to seal the process connection (1) with a cylindrical thread (3) at the sealing surface (4), flat gaskets (2) are employed.

Installation steps

- Use a suitable gasket for the sealing (2), e.g. a copper gasket, corresponding to the measuring medium and the pressure to be measured.
- The sealing surface (4) of the part to be received must have a perfect, clean, and undamaged surface.
- Manually screw the pressure transducer into the receiving thread.
- Do not twist the thread turns during the screwing-in.
- Only screw-in or unscrew the device via the spanner flats using a suitable tool, and with the specified torque. The correct torque depends on the dimension of the process connection and on the used gasket (shape/material). During the screwing-in or unscrewing, do not use the housing as a working surface.
- Subsequently, tighten the threaded-end fitting with the open-end spanner (for $G \frac{1}{4}$ " max. 20 Nm).

12 Electrical installation

The nominal value for the supply voltage for the electrical installation is 24 V DC.

Supply of the METPOINT® PRM SP21/SP22 must be implemented with a stabilised, short-circuit-protected power supply that is protected against overvoltage. The energy supply must come from a source with an energy-limited electrical circuit (10A max./ 30V max.) and a protective separation from the network. **See also EN 61010-1, Clause 9.4.**

Prior to the installation and start-up, the maximum load resistance must be observed. With a nominal value of the supply voltage of **24 V DC**, the max. load resistance is 571 Ω. With a supply voltage that deviates from 24 V DC, the max. load resistance can be calculated according to the following formula:

$$R_L \leq (U_v - 12 \text{ V}) / 0.021 \text{ A } [\Omega]$$



Warning!

Risk of injury in the event of insufficient qualifications!

Improper use can lead to significant personal injury and material damage. All of the activities described in these operating instructions must only be carried out by qualified personnel with the qualifications described hereinafter.

Qualified personnel

Due to the specific training and knowledge concerning the measuring and control technology, and due to their experience and knowledge of the country-specific provisions, standards in force, and directives, qualified personnel are capable of carrying out the described work and of independently identifying the possible risks.

Special employment conditions require further corresponding knowledge, e.g. regarding aggressive media.

Electrical installation

12.1 Pin assignment PRM SP21, 2-wire system

Pin	Function	Description	Conductor colouring
PIN-1	+U _V	Positive (+) connection of the supply voltage	Brown
PIN-2		Not used	
PIN-3	I _{OUT}	Current output	Blue
PIN-4		Not used	

Connection diagram PRM 21, 2-wire system, current output 4 ... 20 mA

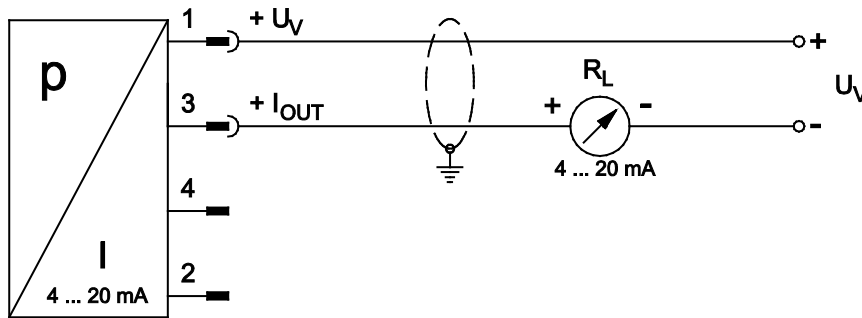

Notes:

The output of the current signal takes place at PIN-3 of the four-pole connector. The **METPOINT® PRM SP21** pressure transducers are supplied ex works with a current output of 4 ... 20 mA. The following scaling was configured in the factory:

4 mA = 0 bar (g)

20 mA = 25 bar (g)

12.2 Pin assignment PRM SP22, 4-wire system

Pin	Function	Description	Conductor colouring
PIN-1	+U _V	Positive (+) connection of the supply voltage	Brown
PIN-2	GND	Analogue reference potential	Black
PIN-3	- U _V	Negative (-) connection of the supply voltage	Blue
PIN-4	+ U _{OUT}	Positive (+) connection of the measurement signal	White

Connection diagram PRM SP22, 4-wire system, voltage output 0 ... 10 V

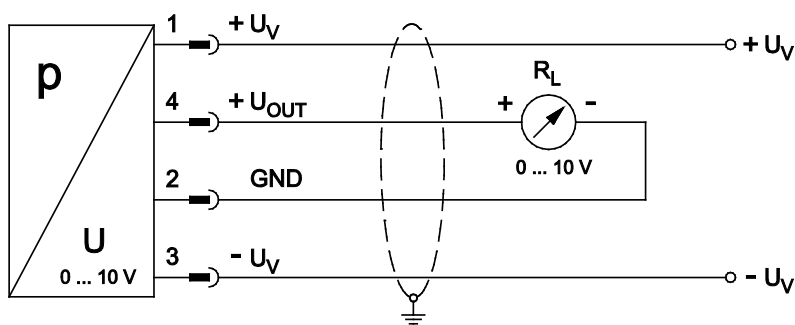

12.3 Pin assignment PRM SP22, 3-wire system

Pin	Function	Description	Conductor colouring
PIN-1	+U _V	Positive (+) connection of the supply voltage	Brown
PIN-2		Not used	Black
PIN-3	- U _V	Negative (-) connection of the supply voltage	Blue
PIN-4	+ U _{OUT}	Positive (+) connection of the measurement signal	White

Connection diagram PRM SP22, 4-wire system, voltage output 0 ... 10 V

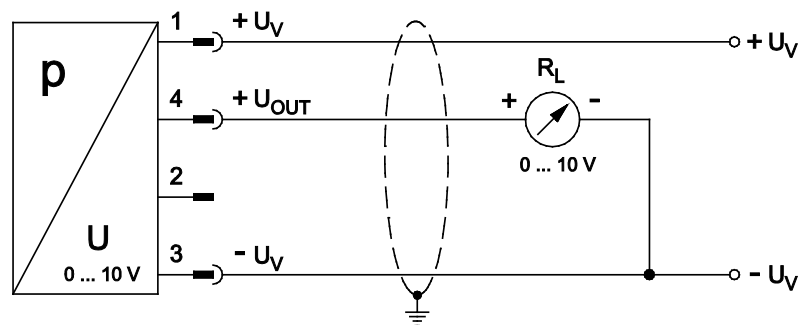

Notes:

The output of the voltage signal takes place at PIN-4 of the four-pole M12 connector. The **METPOINT® PRM SP22** pressure transducers are supplied ex works with a voltage output of 0 ... 10 V. The following scaling was configured in the factory:

0 V = 0 bar (g)

10 V = 25 bar (g)

Electrical installation

The following advice applies to all types of connections:

Shielding is implemented via the shield ring of the connector. The preconditions for proper shielding are that the respective connector is made of metal and that the shield has the shape of a braid. The shielding must be earthed at one end.

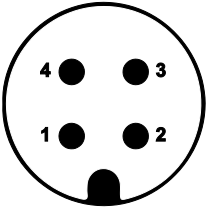
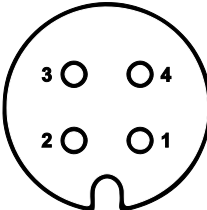
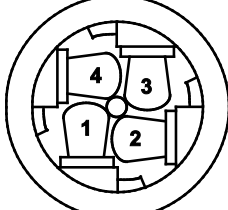
Connector, M12 x 1, 4-pole, a-coded		
Arrangement of the poles plug View transmitter side	Arrangement of the poles - female connector View female connector side	Arrangement of the poles female connector View screwing side
		

The cable must be assembled as follows:

1. Push the components of the plug connector over the cable
2. Cut the cable jacket by 20 mm in length
3. Cut the conductor sheath by 5 mm in length
4. Introduce the cable into the connector according to the pin assignment
5. Assemble/screw together the components of the connector

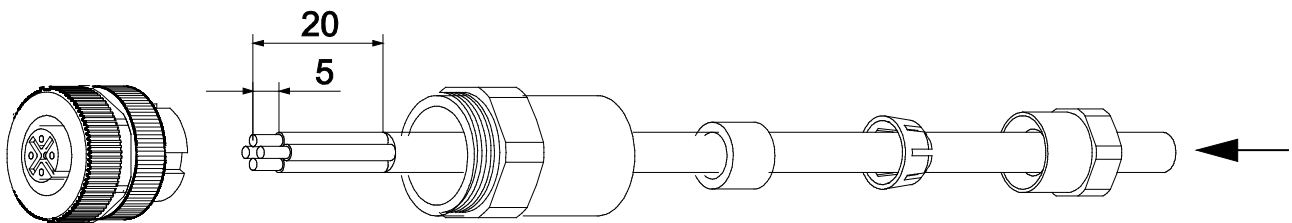

13 Maintenance and calibration

The perfect and safe functioning of the components requires calibration or adjustment at regular intervals.

The METPOINT® PRM SP21/SP22 should be calibrated annually and re-adjusted, if required.



Danger!

Compressed air!

Risk of serious injury or death through contact with quickly or suddenly escaping compressed air or through bursting and/or unsecured plant components.

Measures:

- **Only carry out installation works when the system is pressureless and deactivated.**
- Only use pressure-resistant installation material.
- Make sure that no persons or objects can be hit by condensate or emerging compressed air.
- Check the tightness subsequent to maintenance measures.



Warning!

Risk of injury in the event of insufficient qualifications!

Improper use can lead to significant personal injury and material damage.

All of the activities described in these operating instructions must only be carried out by qualified personnel with the qualifications described hereinafter.

Qualified personnel

Due to the specific training and knowledge concerning the measuring and control technology, and due to their experience and knowledge of the country-specific provisions, standards in force and directives, qualified personnel are capable of carrying out the described work and of independently identifying the possible risks.

Special employment conditions require further corresponding knowledge, e.g. regarding aggressive media.



Warning!

Risk of injury through temperature!



Risk of injury through the contact with very high or low temperatures.

Measures:

- Prior to undertaking maintenance measures, carry out a temperature compensation or wear protective gloves.



Caution!

Damage possible!

Damage and malfunctions at the METPOINT® PRM pressure transducer may occur through incorrect maintenance and calibration or when maintenance and calibration measures are not undertaken at regular intervals.

These can lead to incorrect measuring results and to misinterpretations.

Measures:

- Carry out regular inspections and checks in accordance with the Pressure Equipment Directive (PED).

Maintenance and calibration

13.1 Cleaning/decontamination

Cleaning of the METPOINT® PRM SP21/SP22 must be undertaken using a slightly damp (not wet) cotton cloth or one-way wipe, and mild, commercially available cleaner/soap.

For decontamination, spray the cleaner on an unused cotton cloth or one-way wipe and wipe the component comprehensively. Effectuate subsequent drying using a clean cloth or via air drying.

In addition, the local hygiene provisions need to be observed.



Danger!

Compressed air/reaction products!



Risk of serious injury or death through contact with quickly or suddenly escaping compressed air and through toxic, flammable, or potentially explosive reaction products.

Measures:

- **Only carry out cleaning measures when the system is pressureless.**
- Purge the respective plant component or pressure transducer prior to starting the maintenance works.
- Immediately clean the removed components from media residues.



Warning!



Damage possible!

A too high degree of humidity and hard and pointed objects cause damage to the pressure transducer and to the integrated electronic components.

Measures

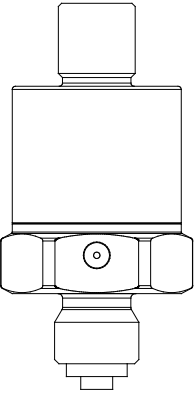
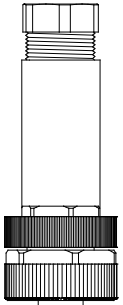

- Never clean with a soaked cloth.
- Do not use pointed or hard objects for cleaning.

14 Scope of delivery

Illustration	Description
	<p>1 x pressure transducer METPOINT® PRM SP21 (0 ... 25 bar) 4 ... 20 mA</p> <p>or</p> <p>1 x pressure transducer METPOINT® PRM SP22 (0 ... 25 bar) 0 ... 10 V</p>
	<p>1x M12 plug, straight</p>
	<p>1 x copper seal</p>
<p>without illustration</p>	<p>1 x P Test record</p>

Accessories

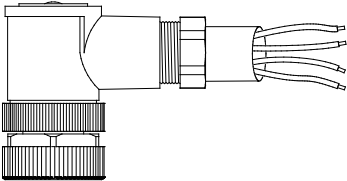
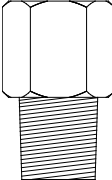
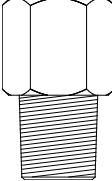
15 Accessories

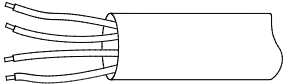
Description	Order no.
<p>M12 Connector, angle (incl. 5 m cable, pre-assembled)</p> 	<p>4025252</p>
<p>Connection adapter R 1/4", SW27</p> 	<p>4025381</p>
<p>Connection adapter NPT 1/4", SW27</p> 	<p>4025382</p>
<p>Copper seal</p> 	<p>4025383</p>
<p>Connecting cable 4 x 0.34 mm² (AWG 22)</p> 	<p>on request</p>

16 Dismantling and disposal

When dismantling the PRM SP21/SP22 pressure transducer, all related parts and operating media must be disposed of separately.

Waste code:

20 01 36

Used electrical and electronic devices with the exception of those which come under 20 01 21, 20 01 23, and 20 01 35.



Warning!

Danger for persons and the environment!

The device must be disposed of in accordance with the European RoHS-2 2011/65/EU Directive. Old appliances must not be disposed of with normal household waste!

Depending on the used medium, residues on the device may represent a danger to the operator or the environment. Therefore, undertake suitable protective measures and dispose of the device properly.

Measures:

- Immediately clean the removed components from media residues when suitable protective measures cannot be undertaken.



Warning!

Risk of injury!



Risk of injury through the contact with very high or low temperatures.

Measures:

- Prior to the removal of the PRM pressure transducer, wait for temperature compensation or wear protective gloves.

Troubleshooting and fault removal

17 Troubleshooting and fault removal

Symptoms	Possible reasons	Measures
There is no signal. Output signal = 0 mA	Break of the signal line	Check the passage
There is no signal. Output signal = 0 mA	Incorrect wiring of the plug	Check the wiring. Observe the PIN assignment.
Deviation of the zero-point signal	Overload limit was exceeded	Replace the pressure transducer. Observe the permissible pressures.
Deviation of the zero-point signal	Operating temperature outside of the specification	Observe the permissible temperatures.
Output signal does not react to pressure changes	Overload through overpressure Operation outside of the specification	Replace the pressure transducer.
Output signal does not react to pressure changes	Load too high (load resistance) Supply voltage too low	Check the voltage. Check the resistance.



Caution!

In the event that the faults cannot be removed through the measures listed above, the pressure transformer needs to be removed from service. It must be ensured that pressure or a signal is no longer applied, and that the pressure transducer is protected against unintentional start-up.

Please contact the manufacturer.

18 Declaration of conformity

BEKO TECHNOLOGIES GMBH
41468 Neuss, GERMANY
Tel.: +49 2131 988-0
www.beko-technologies.com



EC Declaration of Conformity

We hereby declare that the products indicated hereafter comply with the stipulations of the relevant directives and technical standards. This declaration only refers to products in the condition in which they have been placed into circulation. Parts which have not been installed by the manufacturer and/or modifications which have been implemented subsequently remain unconsidered.

Product designation:	METPOINT® PRM
Type:	PRM SP21, PRM SP22
Supply voltage:	12 ... 30 V DC
Data sheet:	PRM-801-1013-FP-B
Max. perm. operating overpressure:	25 bar
Min./max. operating temperature:	- 40°C / + 85°C
Product description and function:	Pressure transducer for industrial applications

Pressure Equipment Directive 97/23/EC

The products do not come under any pressure vessel category and are designed in accordance with Article 3, Clause 3, in compliance with the good engineering practice which applies in the Member States, and are manufactured correspondingly.

EMC Directive 2004/108/EC

Standards applied:	EN 61010-1:2010,	EN 61326-1:2006,
	EN 61326-2-3:2006,	EN 55011:2009+A1:2010

ROHS II Directive 2011/65/EU

The stipulations of the 2011/65/EU Directive on the restriction of the use of certain hazardous substances in electrical and electronic equipment are observed.

Neuss, 23 October 2013

BEKO TECHNOLOGIES GMBH

p.p. Christian Riedel
Head of Quality Department

19 Index

- Accessories 24
- ANSI Z 535 4
- Check 21
- Components 23
- Connection adapter, R ¼ and ¼ NPT 13
- Danger compressed air** 5, 15, 17, 21, 22, 25, 26
- Data 9
- Declaration of conformity 27
- Description SP21 / SP22 14
- Dimension drawing and connections SP21 / SP22 13
- Dimension drawings 12
- Dimensions 12, 13
- Dimensions SP21 / SP22 12
- Electrical data 11
- Electrical installation 17
- Exclusion from the field of application 7
- Fault 26
- Fault clearance 26
- Fault removal 26
- Field of application 7
- Function 14
- Installation and operating instructions 4
- ISO 3864 4
- Maintenance 21
- Maintenance measures** 15
- Maintenance works 22
- Malfunction 26
- Pictograms 4
- Pin assignment SP21, 2-wire 18
- Pin assignment SP22, 3-wire 19
- Pin assignment SP22, 4-wire 18
- Proper use 7
- Scope of delivery 23
- Signal words 4
- Symbols 4
- Technical data 9
- Technical data SP21/SP22 9
- Troubleshooting 26

<p>Headquarters :</p> <p>Deutschland / Germany BEKO TECHNOLOGIES GMBH Im Taubental 7 D-41468 Neuss Tel.: +49 (0)2131 988 0 info@beko-technologies.de</p>	<p>中华人民共和国 / China BEKO TECHNOLOGIES (Shanghai) Co. Ltd. Rm.606 Tomson Commercial Building 710 Dongfang Rd. Pudong Shanghai China P.C. 200122 Tel.: +86 21 508 158 85 beko@beko.cn</p>	<p>France BEKO TECHNOLOGIES S.à.r.l. Zone Industrielle 1 Rue des Frères Rémy F- 57200 Sarreguemines Tel.: +33 387 283 800 Info.fr@beko.de</p>
<p>India BEKO COMPRESSED AIR TECHNOLOGIES Pvt. Ltd. Plot No.43/1, CIEEP, Gandhi Nagar, Balanagar, Hyderabad - 500 037, INDIA Tel.:+91 40 23080275 eric.purushotham@bekoindia.com</p>	<p>Italia / Italy BEKO TECHNOLOGIES S.r.l Via Peano 86/88 I - 10040 Leini (TO) Tel.: +39 011 4500 576 info.it@beko.de</p>	<p>日本 / Japan BEKO TECHNOLOGIES K.K KEIHIN THINK 8 Floor 1-1 Minamiwatarida-machi Kawasaki-ku, Kawasaki-shi JP-210-0855 Tel.: +81 44 328 76 01 info@beko-technologies.co.jp</p>
<p>Benelux BEKO TECHNOLOGIES B.V. Veenen 12 NL - 4703 RB Roosendaal Tel.: +31 165 320 300 info@beko.nl</p>	<p>Polska / Poland BEKO TECHNOLOGIES Sp. z o.o. ul. Chłapowskiego 47 PL-02-787 Warszawa Tel.: +48 (0)22 855 30 95 info.pl@beko.de</p>	<p>Scandinavia www.beko-technologies.com</p>
<p>España / Spain BEKO Tecnológica España S.L. Polígono Industrial "Armenteres" C./Primer de Maig, no.6 E-08980 Sant Feliu de Llobregat Tel.: +34 93 632 76 68 info.es@beko.de</p>	<p>South East Asia BEKO TECHNOLOGIES S.E.Asia (Thailand) Ltd. 75/323 Romkiao Road Sansab, Minburi Bangkok 10510 Thailand Tel.: +66 (0) 2-918-2477 BEKO-info@beko-seasia.com</p>	<p>臺灣 / Taiwan BEKO TECHNOLOGIES Co.,Ltd 16F.-5, No.79, Sec. 1, Xintai 5th Rd., Xizhi Dist., New Taipei City 221, Taiwan (R.O.C.) Tel.: +886 2 8698 3998 info@beko.com.tw</p>
<p>Česká Republika / Czech Republic BEKO TECHNOLOGIES s.r.o. Mlýnská 1392 CZ - 562 01 Usti nad Orlici Tel.: +420 465 52 12 51 info.cz@beko.de</p>	<p>United Kingdom BEKO TECHNOLOGIES LTD. 2 West Court Buntsford Park Road Bromsgrove GB-Worcestershire B60 3DX Tel.: +44 1527 575 778 Info.uk@beko.de</p>	<p>USA BEKO TECHNOLOGIES CORP. 900 Great SW Parkway US - Atlanta, GA 30336 Tel.: +1 (404) 924-6900 beko@bekousa.com</p>

Original instructions in German.

Subject to technical changes / errors excepted.

METPOINT_PRM_SP21_SP22_Manual_EN_2014_01