

## Drying | EVERDRY® FRL

# Cooling in a closed cycle: the Heat Regenerating Adsorption Dryer EVERDRY® FRL

Standardised system concepts with a wide range of possible variations: To solve complex tasks in compressed air drying with large volume flow rates economically!

In-house engineering for individual system solutions!

### The classic concept: Innovatively implemented via the latest system technology

Tried and tested process engineering, paired with the latest control technology, stand for the three variable basic concepts that work ideally worldwide in any climate zone. The standard series is broken down into 23 performance levels from 580 to 20,000 m<sup>3</sup>/h. Higher volume flow rates can also be achieved at the customer's request.

In the EVERDRY® FRL, desorption takes place in a counter-flow direction of adsorption with heated fan-blown air and cooling is by fan-blown air in the same flow in a closed cooling cycle (loop). This means that the cooling stage arises independent of the ambient conditions, so that this adsorption dryer can be used worldwide in all climate zones. No compressed air is needed for the cooling stage (Zero Purge).

Model:	FRP	FRA	FRL
Pressure dew point	-40 °C	-40 °C	-40 °C -70 °C option
Quality Class	-.2.-	-.2.-	-.2.- -.1.-

FR

### › Application Oriented Solutions

- › Added value by utilising comprehensive competence
- › Total concept instead of just individual components
- › Informative and user-friendly touch panel control system
- › Easy to maintain

### › Reliable Process Management

- › Safe function monitoring with sensor technology
- › High-quality high-temperature galvanising
- › Tried and tested, maintenance-friendly components

### › Energy-optimised Concept

- › Beneficial individual valves
- › Energy-efficient dew point control system

# Heat Regenerating Adsorption Dryer: In-house Engineering for Individual System Solutions

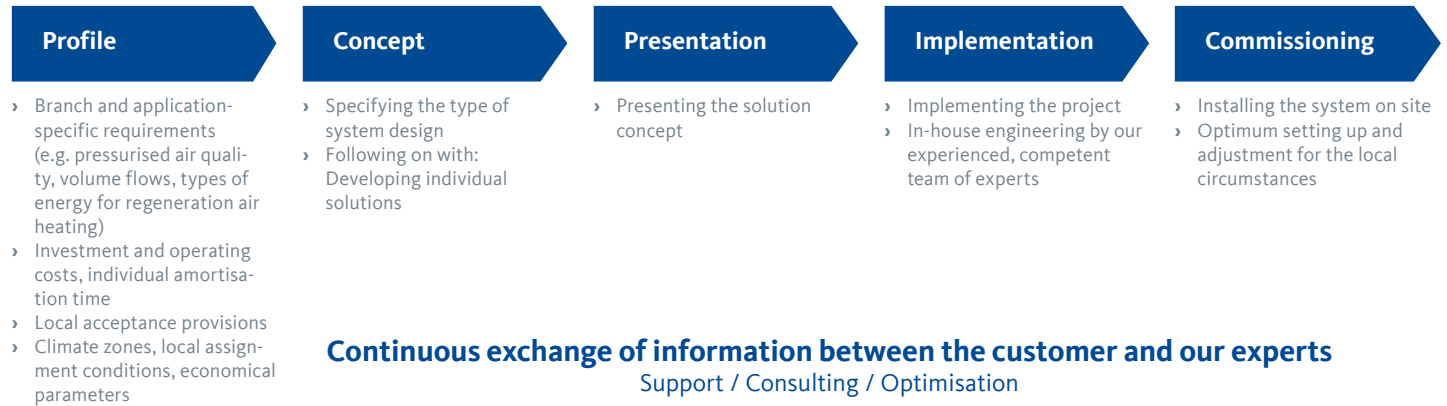

## Function Process for EVERDRY® FRL

### Adsorption stage

The moist compressed air flow enters the system through the valve **K1** and into the adsorption vessel **B1**. The flow distributor ensures an even distribution of the moist compressed air. The moisture will be absorbed by the desiccant during the through flow. The dried pressurised air is then routed via the

outlet valve **R1** and the system outlet to the consumer positions. The adsorption process ends based on either the time or dew point (option). Adsorption takes place from the bottom to the top.

### Desorption stage

Whilst the compressed air is being dried in the adsorption vessel **B1**, the adsorption vessel **B2** that has just been saturated with moisture is regenerated. Before the start of regeneration, the pressure in the adsorption vessel **B2** is gently relieved to atmospheric pressure. Desorption takes place with aspirated ambient air. The regeneration fan conveys the ambient air to the subsequent heater. This is where the fan-blown air is heated up to the necessary desorption temperature. The regeneration fan creates an increase in temperature that has a positive effect on the heater's performance.

The air flow from the fan passes through the valves **K8** and **K6** to the desorbing adsorption vessel **B2**. The moisture absorbed by the desiccant evaporates and is routed by the air flow from the fan through the valves **K4** and **K9** into the atmosphere. Energy-optimised desorption takes place by a counter-flow process. This means that the moisture from the adsorption vessel reaches the atmosphere by the shortest path. The heated fan-blown air cools down when it flows through the adsorption vessel **B2** since the water evaporates. The outlet temperature of the desorption air is therefore not much higher than the evaporation temperature (approx. 40 – 60°C). The moisture level in the desiccant bed reduces with the desorption process. Decreasing moisture levels result in an increase of the outlet temperature of the desorption air. The desorption stage ends when the necessary process temperature is reached. Desorption takes place in the opposite direction to adsorption from the top to the bottom.

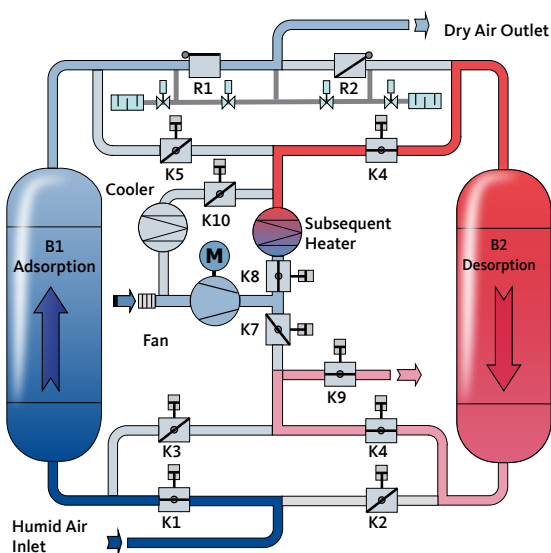

### Standby stage

In the standby stage, the freshly regenerated vessel with the closed inlet valve (**in this case K2**) is under operating pressure. During this stage, the standby vessel is kept pressurised via the open pressure build-up valve. If the adsorption stage is monitored via a dew point dependent control system (option) and is then completed, then the duration of the standby stage is dependent on the loading status of the adsorption vessel

(**in this case B1**). The switch over process will be only be initiated when the drying agent break-down capacity has been reached (increase in the pressure condensation point). If the system is operated in the “time-dependent switch over” mode, then the initiation of the switching over process will be executed when the set cycle time has expired.

### Parallel Stage

Before the switching over process is executed for the adsorption vessel (**in this case from B1 to B2**), this will be switched into parallel function by opening the inlet valve (**in this case K2**)

accordingly. The pressurised air flows over both adsorption vessels for approx. 5 – 15 minutes (can be set individually).

### Switching Over Procedure

At the end of parallel stage, the system switches over to the regenerated adsorption vessel (**in this case B2**) in the following steps:

- › **The inlet valve (in this case K1) on the saturated adsorption vessel (in this case B1) is closed**
- › **The pressure build-up valve is closed**
- › **Open the pressure relief valve for the adsorption vessel to be regenerated (in this case B1)**
- › **Open the regeneration valves (in this case K3, K5, K8)**
- › **Switch on the fan and heater**

The vessel saturated with moisture **B1** is now in the desorption stage whereas the adsorption vessel **B2** takes over drying the compressed air.

# EVERDRY® FRL: FRL 4200 – FRL 20000

LOOP

- › Designed for fully automated and continuous operation
- › Desorption in a counter-flow to the adsorption direction by means of heated fan-blown air
- › Cooling by means of fan-blown air in a closed cooling cycle (loop)
- › No pressurised air losses for regeneration
- › Designed for indoor installation
- › Flow-optimised individual valves to minimise the pressure loss

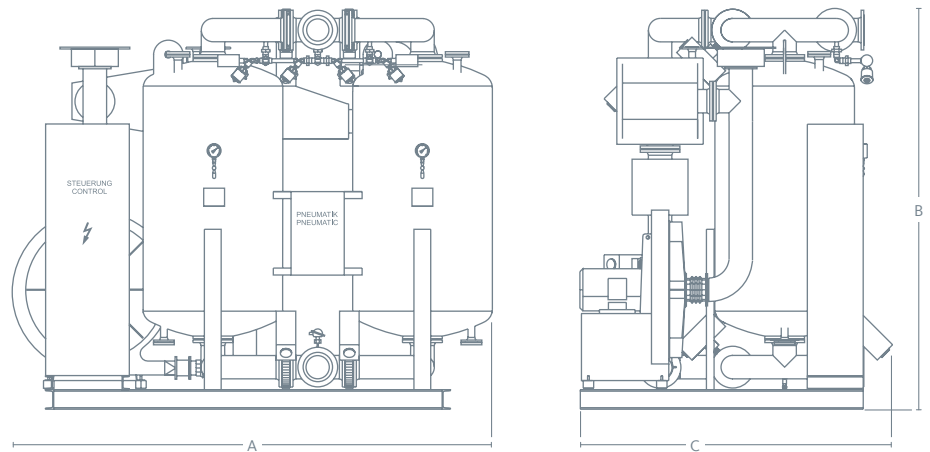

EVERDRY®	FRL 4200	FRL 5000	FRL 6000	FRL 7000	FRL 8200	FRL 9400
Volume flow rate (m <sup>2</sup> /h)	4200	5000	6000	7000	8200	9350
Connection PN 16 DIN 2633	DN 150	DN 150	DN 150	DN 150	DN 150	DN 200
Connected load (kW)	52.5	69.5	78.5	92	105.5	123
Dimensions						
A (mm)	3375	3480	3755	3805	4335	4265
B (mm)	2900	2955	2995	3055	3190	3275
C (mm)	2250	2250	2485	2525	2605	2800
Weight (kg)	5400	6100	7000	7800	9500	10650

EVERDRY®	FRL 10600	FRL 12000	FRL 13500	FRL 15000	FRL 17000	FRL 20000
Volume flow rate (m <sup>2</sup> /h)	10600	12000	13500	15000	17000	20000
Connection PN 16 DIN 2633	DN 200	DN 200	DN 200	DN 200	DN 250	DN 250
Connected load (kW)	141	159	177	198.5	220	247
Dimensions						
A (mm)	5000	5400	5600	5900	5600	6600
B (mm)	3400	3400	3500	3500	3650	3700
C (mm)	2900	3000	3100	3200	3200	3500
Weight (kg)	14000	15200	17000	19500	21500	24500

Operating conditions*	
Medium	Compressed air
Operating pressure	7 bar [g]
Inlet temperature	35 °C
Inlet humidity	saturated
Pressure dew point	-40 °C / -70 °C (option)

Limits of use*	
Operating pressure	4...10 bar [g]
Inlet temperature	5...43 °C
Ambient temperature	5...40 °C
Max. fan aspiration	35 °C / 85 % r. F. 40 °C / 70 % r. F.

Electrical connection*	
Power supply	3 Ph.   400 V   50 Hz
Protection class	IP 54, according to IEC 529 (no explosion protection)
Version	according to VDE / IEC
Permissible voltage deviation	+/- 10 %

\* Different conditions on request

Reference conditions according to DIN / ISO 7183	
Medium	Compressed air
Volume flow rate in m <sup>3</sup> /h relative to	20 °C (1 bar [g])
Operating pressure	7 bar [g]
Compressed air inlet temperature	35 °C
Inlet humidity	saturated

### Cooling stage

To prevent temperature and dew point peaks after the switch over, the heat stored in the desiccant after the desorption stage will be carried off by the cold fan-blown air flow. Cooling takes place in the same direction as adsorption from the bottom to the top. The particular feature of the systems in the FRL/FRL-V series is that the air flow from the fan is guided in a closed cycle. This means that the cooling stage is independent of the ambient conditions. This procedure prevents a pre-loading of the desiccant through ambient moisture. Before the cooling stage starts, the regeneration outlet valve **K9** closes.

The cooling cycle with the cooler to return the cooling air is activated by opening the valve **K10**. The cooling stage ends when the necessary process temperature is reached. At the end of the cooling stage, the regeneration valves close. This is followed by a gradual build up of pressure in the regenerated adsorption vessel **B2**. The integrated pressure transmitters monitor the correct build up of pressure. The next stage (standby) only begins when both vessels have reached the same operating pressure. Cooling takes place from the bottom to the top with fan-blown air in a closed cycle (loop).

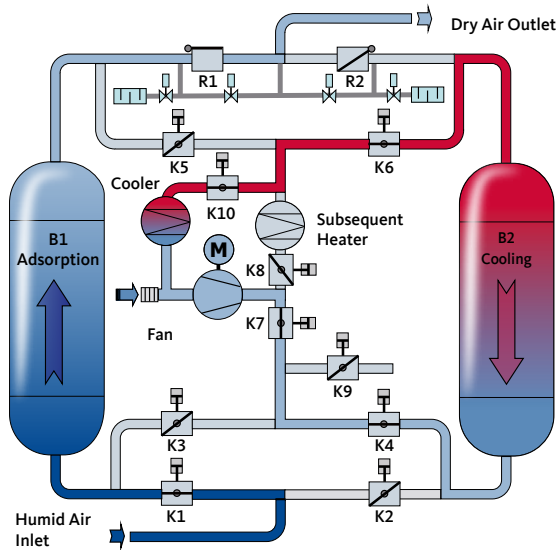

# The Heat Regenerating Adsorption Dryer: At home throughout the world.

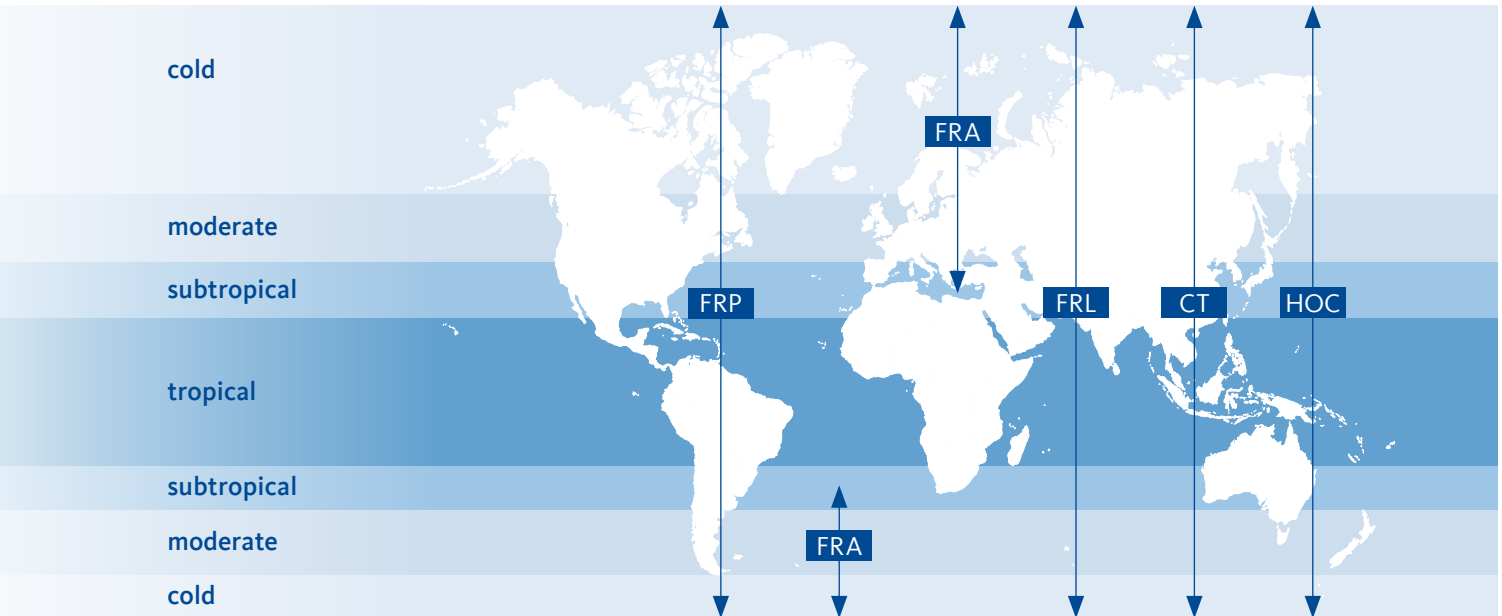

## Do **you** have questions about the best way of processing your compressed air?

We have the answers! We offer efficient solutions for any type of processing chain. Please contact us with your queries. We would be delighted to tell you more about our condensate

treatment, filtration, drying, measuring and process technology, and our comprehensive services.

Visit us at



**BEKO TECHNOLOGIES GMBH**  
Im Taubental 7 | D-41468 Neuss

Telephone +49 2131 988 - 1000  
info@beko-technologies.com  
www.beko-technologies.com



Subject to technical changes without prior notice. Errors and omissions excepted.