



Drying | EVERDRY® FRA

Cooling with fan-blown air: the Heat Regenerating Adsorption Dryer EVERDRY® FRA

Standardised system concepts with a wide range of possible variations: To solve complex tasks in compressed air drying with large volume flow rates economically!

In-house engineering for individual system solutions!

The classic concept: innovatively implemented via the latest system technology

Tried and tested process engineering, paired with the latest control technology, stand for the three variable basic concepts that work ideally worldwide in any climate zone. The standard series is broken down into 23 performance levels from 580 to 20,000 m³/h. Higher volume flow rates can also be achieved at the customer's request.

In the EVERDRY® FRA, desorption takes place in a counter-flow direction of adsorption with heated fan-blown air and cooling is by fan-blown air in the same flow. This means that there is no pressurised air loss for regeneration (ZERO Purge). The use of an adsorption dryer depends on the ambient conditions, which have to be checked before use.

Model:	FRP	FRA	FRL
Pressure dew point	-40 °C	-40 °C	-40 °C -70 °C option
Quality Class	-2.-	-2.-	-2.- -1.-

FR

› Application Oriented Solutions

- › Added value by utilising comprehensive competence
- › Total concept instead of just individual components
- › Informative and user-friendly touch panel control system
- › Easy to maintain

› Reliable Process Management

- › Safe function monitoring with sensor technology
- › High-quality high-temperature galvanising
- › Tried and tested, maintenance-friendly components

› Energy-optimised Concept

- › Beneficial individual valves
- › Energy-efficient dew point control system

Heat Regenerating Adsorption Dryer: In-house Engineering for Individual System Solutions

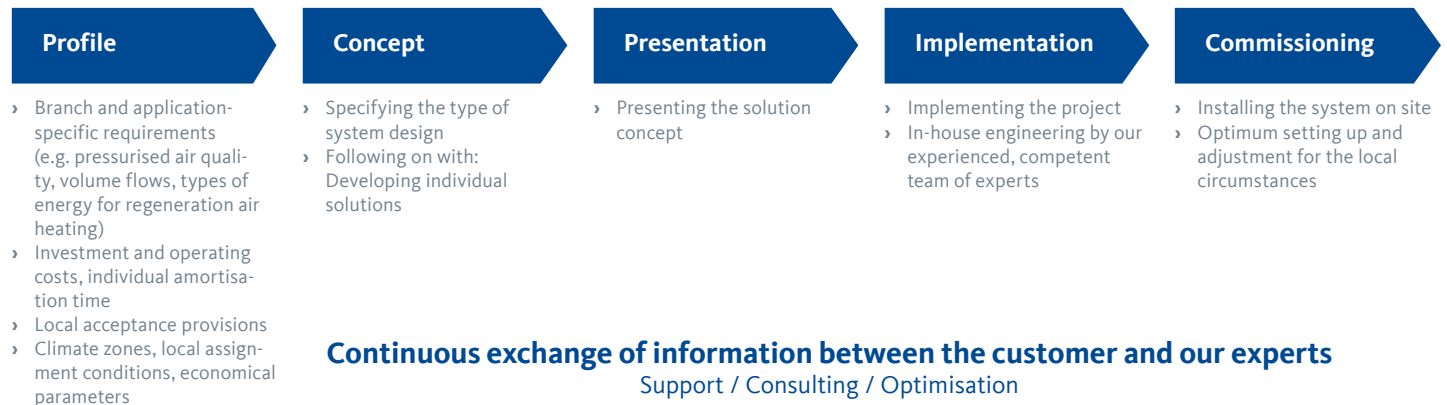

Function Process for EVERDRY® FRA

Adsorption stage

The moist compressed air flow enters the system through the valve **K1** and into the adsorption vessel **B1**. The flow distributor ensures an even distribution of the moist compressed air. The moisture will be absorbed by the drying agents during the through flow. The dried pressurised air is then

routed via the outlet valve **R1** and the system outlet to the consumer positions. The adsorption process ends based on either the time or dew point (option). Adsorption takes place from the bottom to the top.

Desorption stage

Whilst the compressed air is being dried in the adsorption vessel **B1**, the adsorption vessel **B2** that has just been saturated with moisture is regenerated. Before the start of regeneration, the pressure in the adsorption vessel **B2** is gently relieved to atmospheric pressure. Desorption takes place with aspirated ambient air. The regeneration fan conveys the ambient air to the subsequent heater. This is where the fan-blown air is heated up to the necessary desorption temperature. The regeneration fan creates an increase in temperature that has a positive effect on the heater's performance.

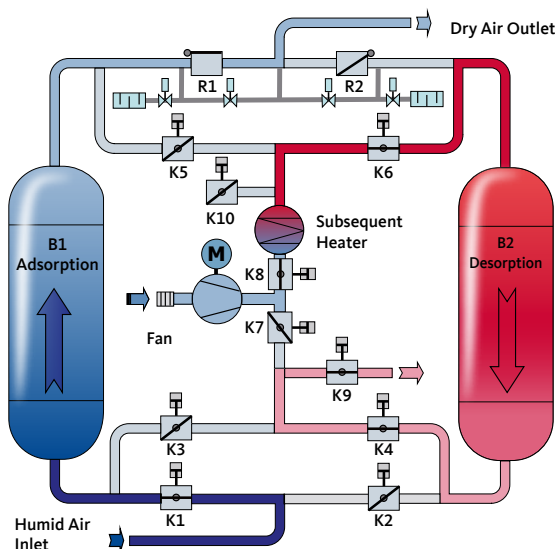

The air flow from the fan passes through the valves **K8** and **K6** to the desorbing adsorption vessel **B2**. The moisture absorbed by the desiccant evaporates and is routed by the blown-air flow from the fan through the valves **K4** and **K9** into the atmosphere. Energy-optimised desorption is executed via a counter-flow process. This means that the moisture from the adsorption vessel reaches the atmosphere by the shortest path. The heated fan-blown air cools down when it flows through the adsorption vessel **B2** since the water evaporates. The outlet temperature of the desorption air is therefore not much higher than the evaporation temperature (approx. 40 – 60°C). The moisture level in the desiccant bed reduces with the desorption process. Decreasing moisture levels result in an increase of the outlet temperature of the desorption air. The desorption stage ends when the necessary process temperature is reached. Desorption takes place in the opposite direction to adsorption from the top to the bottom.

Standby stage

In the standby stage, the freshly regenerated vessel with the closed inlet valve (**in this case K2**) is under operating pressure. During this stage, the standby vessel is kept pressurised via the open pressure build-up valve. If the adsorption stage is monitored via a dew point dependent control system (option) and is then completed, then the duration of the standby stage is dependent on the loading status of the adsorption vessel

(**in this case B1**). The switch over process will only be initiated when the desiccant break-down capacity has been reached (increase in the pressure dew point). If the system is operated in the “time-dependent switch over” mode, then the initiation of the switching over process will be executed when the set cycle time has expired.

Parallel Stage

Before the switching over process is executed for the adsorption vessel (**in this case from B1 to B2**), this will be switched into parallel function by opening the inlet valve (in this case K2) accordingly.

The pressurised air flows over both adsorption vessels for approx. 5 – 15 minutes (can be set individually).

Switching Over Procedure

At the end of parallel stage, the system switches over to the regenerated adsorption vessel (**in this case B2**) in the following steps:

- › **The inlet valve (in this case K1) on the saturated adsorption vessel (in this case B1) is closed**
- › **The pressure build-up valve is closed**
- › **Open the pressure relief valve for the adsorption vessel to be regenerated (in this case B1)**
- › **Open the regeneration valves (in this case K3, K5, K8, K3)**
- › **Switch on the fan and heater**

The vessel saturated with moisture **B1** is now in the desorption stage whereas the adsorption vessel **B2** takes over drying the compressed air.

EVERDRY® FRA: FRA 4200 – FRA 20000

ZERO PURGE

- › Designed for fully automated and continuous operation
- › Desorption in a counter-flow adsorption direction by means of heated fan air
- › No pressure loss for regeneration
- › Cooling with fan-blown air
- › Designed for indoor installation
- › Flow-optimised individual valves to minimise the pressure loss

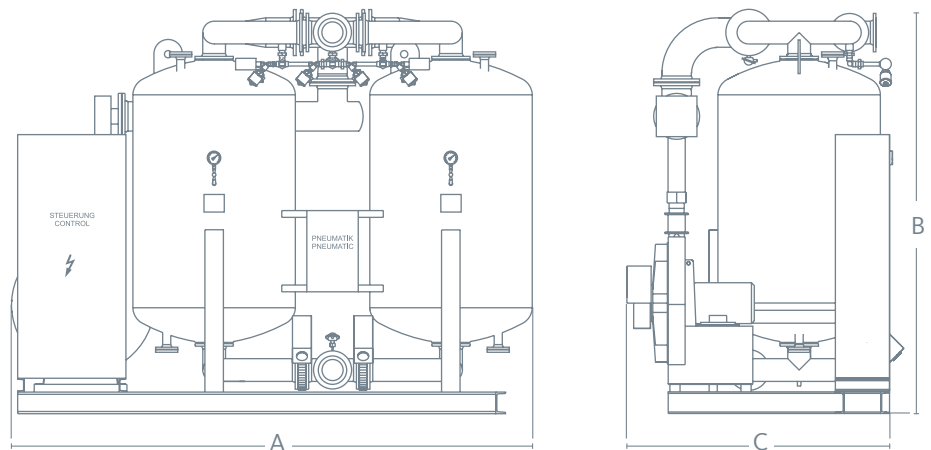

EVERDRY®	FRA 4200	FRA 5000	FRA 6000	FRA 7000	FRA 8200	FRA 9400
Volume flow rate (m³/h)	4200	5000	6000	7000	8200	9350
Connection PN 16 DIN 2633	DN 150	DN 150	DN 150	DN 150	DN 150	DN 200
Connected load (kW)	52.5	69.5	78.5	92	105.5	123
Dimensions						
A (mm)	3460	3605	3860	3915	4200	4500
B (mm)	3095	3155	3200	3255	3300	3450
C (mm)	1935	1935	2010	2265	2565	2700
Weight (kg)	5200	5900	6500	7400	8700	9900

EVERDRY®	FRA 10600	FRA 12000	FRA 13500	FRA 15000	FRA 17000	FRA 20000
Volume flow rate (m³/h)	10600	12000	13500	15000	17000	20000
Connection PN 16 DIN 2633	DN 200	DN 200	DN 200	DN 200	DN 250	DN 250
Connected load (kW)	141	159	177	198.5	220	247
Dimensions						
A (mm)	5200	5300	5400	5800	6000	6200
B (mm)	3500	3550	3550	3600	3700	3750
C (mm)	2800	2850	2900	3100	3500	3800
Weight (kg)	12800	14200	16000	18500	20500	23500

Operating conditions*	
Medium	Compressed air
Betriebsdruck	7 bar [g]
Inlet temperature	35 °C
Inlet humidity	saturated
Pressure dew point	-40 °C

Limits of use*	
Betriebsdruck	4...10 bar [g]
Inlet temperature	5...43 °C
Ambient temperature	5...40 °C
Maximum fan aspiration	35 °C / 40 % r. F. / 30 °C / 50 % r. F.

Electrical connection*	
Power supply	3 Ph. 400 V 50 Hz
Protection class	IP 54, acc. to IEC 529 (no explosion protection)
Version	according to VDE / IEC
Permissible voltage deviation	+/- 10 %

* Different conditions on request

Reference conditions according to DIN / ISO 7183	
Medium	Compressed air
Volume flow rate in m³/h relative to	20 °C (1 bar [g])
Operating pressure	7 bar [g]
Compressed air inlet temperature	35 °C
Inlet humidity	saturated

Cooling stage

To prevent temperature and dew point peaks after the switch over, the heat stored in the desiccant after the desorption stage will be routed off by the cold fan-blown air flow. Cooling takes place in the same direction as adsorption from the bottom to the top. This procedure prevents a pre-loading of the desiccant through ambient moisture in the outlet area of the adsorption vessel, which has a decisive influence on the quality of drying. The cooling stage ends when the necessary process temperature is reached. At the end of the cooling stage, the regeneration valves **K4**, **K6**, **K7**, **K10** close.

This is followed by a gradual build up of pressure in the regenerated adsorption vessel **B2**. The integrated pressure transmitters monitor the correct build up of pressure.

The next stage (standby) only begins when both vessels have reached the same operating pressure. Cooling takes place in the same direction as adsorption from the bottom to the top.

The desiccant has to be cooled efficiently to ensure a constantly high quality of the compressed air. In unfavourable climatic conditions (ambient temperature or humidity too high), adequate cooling is no longer possible with ambient air. In order to also guarantee process reliability in such cases, your EVERDRY® adsorption dryer is fitted with a sensor which constantly measures the ambient temperature as well as the relative humidity of the ambient air. The resulting dew point for the ambient air is calculated from this. These values are displayed on the screen of the dryer's control panel. If pre-set limits are exceeded, then the cooling stage is executed with a small share of the dried compressed air instead of with the ambient air (compressed air cooling). As soon as the values fall below the pre-set limits again, the system switches back to ambient air cooling for the next cooling stage. This function increases the operational reliability of your EVERDRY® and ensures a constantly high quality of the compressed air independent of the ambient conditions.

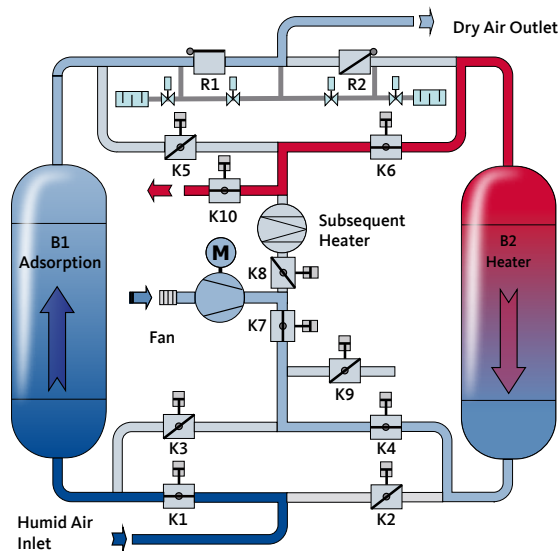

The Heat Regenerating Adsorption Dryer: At home throughout the world.

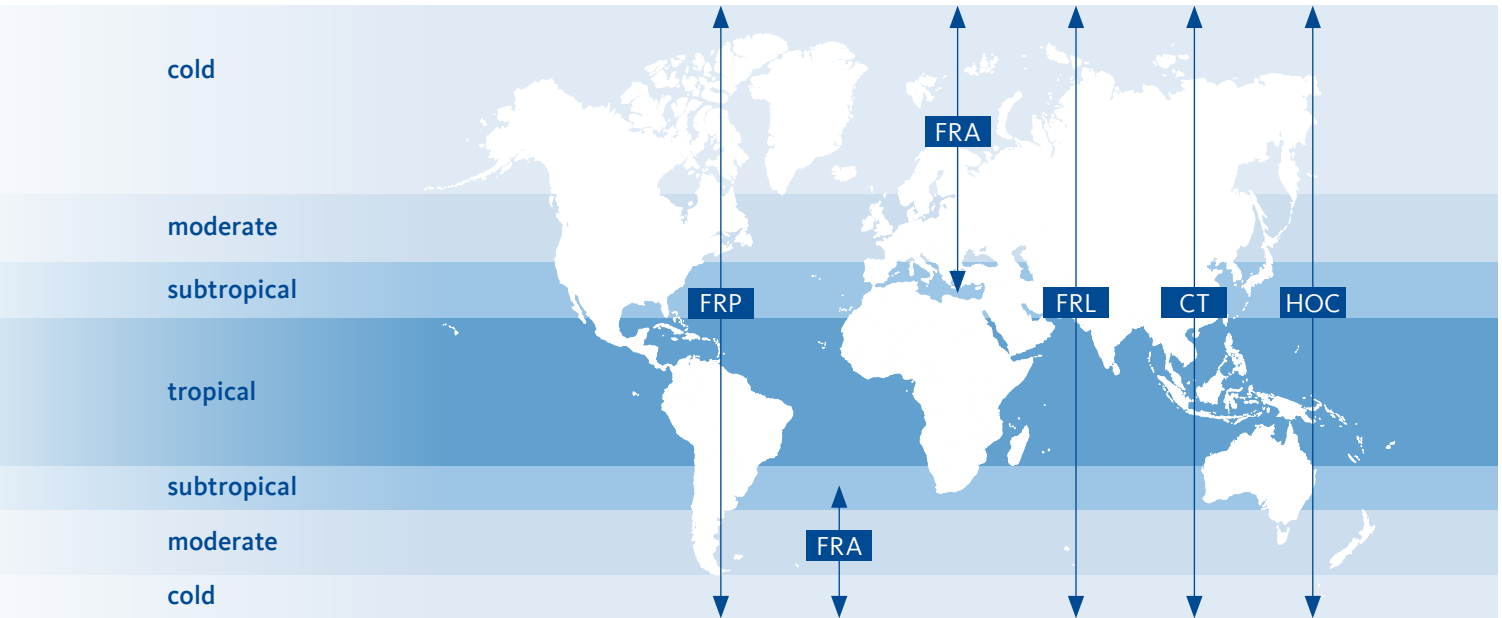

Do **you** have questions about the best way of processing your compressed air?

We have the answers! We offer efficient solutions for any type of processing chain. Please contact us with your queries. We would be delighted to tell you more about our condensate

treatment, filtration, drying, measuring and process technology, and our comprehensive services.

Visit us at



BEKO TECHNOLOGIES Ltd
Unit 11-12 Moons Park
Burnt Meadow Road
North Moons Moat
Redditch, B98 9PA

Phone +44 (0) 1527 575778
info@beko-technologies.co.uk
www.beko-technologies.co.uk



Subject to technical changes without prior notice. Errors and omissions excepted.