



## Measurement technology | METPOINT® BDL compact

Volumetric flow, pressure dew point, pressure, effective flow, temperature and residual oil vapour content. All parameters at your fingertips: METPOINT® BDL compact

For the efficient treatment of your compressed air, you need to know the dew point, pressure, flow and temperature. Accurate measurements and comprehensive data analysis are indispensable for proper quality control.

### Make quality visible – by recording it

The METPOINT® BDL compact data logger is a compact device with powerful measuring and evaluation functions, including instant alarms in the case of exceedances.

It measures all key quality parameters for compressed air and enables you to evaluate the efficiency of your system by identifying hidden cost drivers. User-friendly statistics and charts provide the information you need for effective quality and energy management.

The METPOINT® BDL compact features two sensor inputs.

On request, it is available with two additional digital or analog inputs, e.g. for power meters or pressure sensors. All critical parameters of your processes can be called up on the screen, so that you can intervene without delay if required. The compact device can be equipped with a 2 GB data logger, so that you can track performance over time, which is a prerequisite for continuous quality and efficiency improvement.

### › Access your data from anywhere in the world

- › Integration into company LAN and internet
- › Process data output per TCP/RTU Modbus output for PLC, facility management system, etc.
- › Integrated web server with intuitive browser interface (optional)
- › Data logger (optional)
- › Efficient process and cost analyses
- › Extra safety thanks to limit alarm signals

### › User-friendly and adaptable

- › 3.5" colour touch screen display with intuitive menus
- › All process data available in table or chart format for further analysis
- › Modular design: catering for up to 4 sensors of any type
- › Process data tracking

<b>Technical data of METPOINT® BDL compact</b>	
Colour display	3.5" touch panel, TFT transmissive
Supply voltage	100 ... 240 VAC / 50 ... 60 Hz, max. 25 VA
Supply voltage for sensors	Output voltage: 24 VDC $\pm$ 10 %
Output current - analog board	120 mA in total for both channels
Output current - digital board	120 mA in continuous mode / channel
Max. output current through all channels	280 mA
Ambient temperature	0 ... +50 °C
Storage and transport temperature	-20 ... +70 °C
Ambient air humidity	0 ... 95 %, no condensation
Protection class	IP 44, EN 60529
Lithium manganese dioxide battery	Panasonic CR2032
Connections	7x cable connections M12x1.5 Body: Brass, nickel-plated Terminal size: 3-7 mm, WS=16 mm; torque: 8 Nm 1x RJ45 for Ethernet connection
Interfaces	USB port (USB 2.0) / Ethernet interface, Modbus TCP RS485 interface, Modbus RTU SDI interface (Serial Data Interface)
Sensor inputs	4 (2x2) sensor inputs for analog and digital sensors, free assignment Analog signals: 0/4 ... 20 mA, 0 ... 1/10/30 V pulse signals Pt100, Pt1000 Digital signals: RS485, BEKO-SDI
Alarm outputs (alarm relays)	2x floating switchover contacts; programmable, for alarm management
Analog output and pulse output	Looped for sensors with own signal output, e.g. FS / DP series
Data logger	4 GB memory card
Housing materials	Housing: Aluminium, powder-coated polyester front foil (anti-glare) 3M adhesive (3M7952 / 3M467)
Housing dimensions	180 x 166 x 115 mm
Weight	2.7 kg
Optional	Web server
Optional	Electrically insulated pulse output (2x) max. 30V AV / 60V DC; 250 mA
Optional	Consumption statistics, daily/weekly/monthly reports

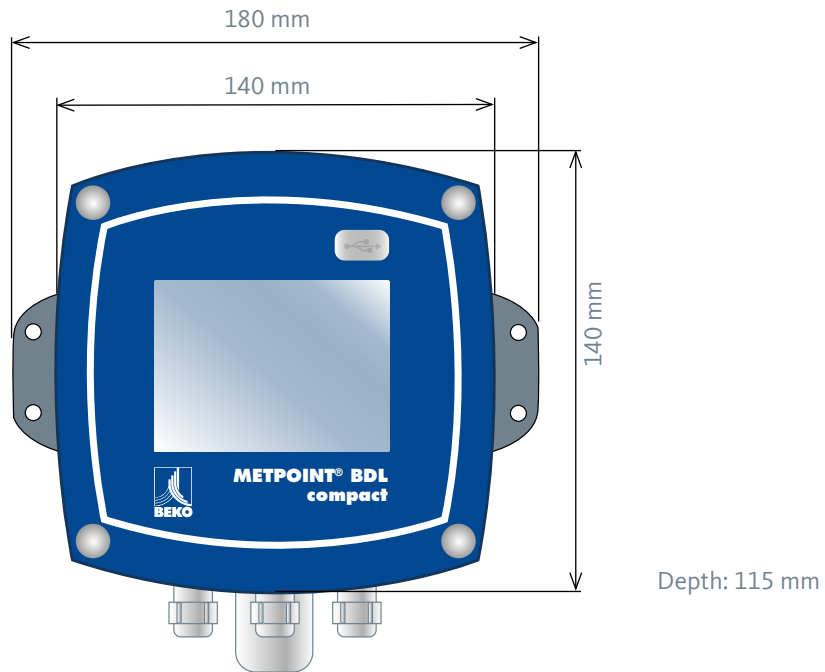

METPOINT® BDL compact	BDLc_2D 2 digital inputs	BDLc_2A 2 analog inputs	BDLc_2D2A 2 digital and 2 analog inputs	BDLc_2DE 2 digital inputs and Ethernet interface	BDLc_2AE 2 analog inputs and Ethernet interface
Order no.	4027685	4027730	4027738	4027754	4027800

METPOINT® BDL compact	BDLc_2D2AE 2 digital, 2 analog inputs and Ethernet interface	BDLc_4D 4 digital inputs	BDLc_4A 4 analog inputs	BDLc_4DE 4 digital inputs and Ethernet interface	BDLc_4AE 4 analog inputs and Ethernet interface
Order no.	4027809	4027817	4027825	4027833	4027837

For METPOINT® BDL compact	Option A Web server	Option B Calculation function	Option C Totaliser
Order no.	4027872	402873	4027874

For METPOINT® BDL compact	Power supply 24 VAC	METPOINT® READER software SW201	METPOINT® Connect software
Order no.	on request	4024218	4025454

# Principle of METPOINT® BDL compact

The METPOINT® BDL compact is an advanced data logger with a display for the recording of critical parameters in compressed air and gas applications. The electronic recording system evaluates all incoming signals that are relevant for your application. The values are displayed and stored, so that you can track your process performance over time. All measurements and alarms are archived and can be transferred to the master control system. The data logger with display enables you to evaluate

your processes so that you can intervene quickly, should this be necessary. It caters for up to twelve analog and/or digital sensors that can be easily connected and configured as required. The 7" colour display with touch buttons shows all measured values, characteristics and exceedances. In combination with a consumption analysis, you are able to calculate your daily, weekly or monthly costs.

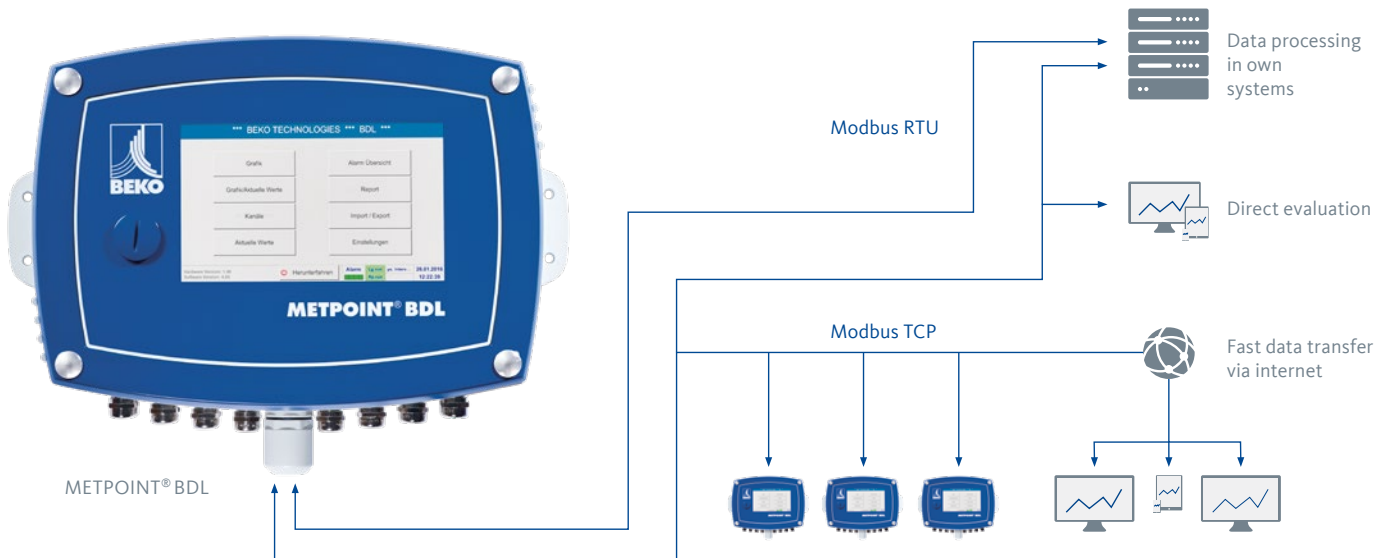

## Do you have questions about the best way of processing your compressed air?

We have the answers! We offer efficient solutions for any type of processing chain. Please contact us with your queries. We would be delighted to tell you more about our condensate

treatment, filtration, drying, measuring and process technology, and our comprehensive services.

Visit us at



**BEKO TECHNOLOGIES Ltd**

Unit 11-12 Moons Park  
Burnt Meadow Road  
North Moons Moat  
Redditch, B98 9PA

Phone +44 (0) 1527 575778  
info@beko-technologies.co.uk  
www.beko-technologies.co.uk



Subject to technical changes without prior notice. Errors and omissions excepted.